



HY11P14

Application of the Pricing Scales That Adhere to OIML Standard

HY11P14

Application of the Pricing Scales that Adhere to OIML Standard



Table of Contents

| | |
|---|-----------|
| 1. BRIEF INTRODUCTION | 5 |
| 2. THEORY DESCRIPTION | 7 |
| 2.1. RMS Noise | 7 |
| 2.2. Temperature | 8 |
| 2.3. INL | 8 |
| 2.4. Software Display Request | 8 |
| 2.5. HY11P14 Specification | 9 |
| 3. CIRCUIT THEORY | 10 |
| 3.1. ADC and Power System | 10 |
| 3.2. Low Battery | 11 |
| 4. 50/60HZ NORMAL MODE REJECTION | 13 |
| 5. SOFTWARE FUNCTION | 14 |
| 5.1. Calibration Mode | 14 |
| 5.2. The Pricing Mode | 16 |
| 6. TESTING FORMS | 19 |
| 6.1. Discrimination | 19 |
| 6.2. Weighting Performance | 20 |
| 6.3. Zero Return | 21 |
| 6.4. Creep | 22 |
| 6.5. Stability of Equilibrium | 23 |
| 6.6. Repeatability | 24 |
| 6.7. Tare | 25 |

HY11P14

Application of the Pricing Scales that Adhere to OIML Standard



| | |
|------------------------|----|
| 6.8. Temperature | 26 |
| 7. DEMO CODE | 27 |

Attention :

1. HYCON Technology Corp. reserves the right to change the content of this datasheet without further notice. For most up-to-date information, please constantly visit our website:
<http://www.hycontek.com> .
2. HYCON Technology Corp. is not responsible for problems caused by figures or application circuits narrated herein whose related industrial properties belong to third parties.
3. Specifications of any HYCON Technology Corp. products detailed or contained herein stipulate the performance, characteristics, and functions of the specified products in the independent state. We does not guarantee of the performance, characteristics, and functions of the specified products as placed in the customer's products or equipment. Constant and sufficient verification and evaluation is highly advised.
4. Please note the operating conditions of input voltage, output voltage and load current and ensure the IC internal power consumption does not exceed that of package tolerance. HYCON Technology Corp. assumes no responsibility for equipment failures that resulted from using products at values that exceed, even momentarily, rated values listed in products specifications of HYCON products specified herein.
5. Notwithstanding this product has built-in ESD protection circuit, please do not exert excessive static electricity to protection circuit.
6. Products specified or contained herein cannot be employed in applications which require extremely high levels of reliability, such as device or equipment affecting the human body, health/medical equipments, security systems, or any apparatus installed in aircrafts and other vehicles.
7. Despite the fact that HYCON Technology Corp. endeavors to enhance product quality as well as reliability in every possible way, failure or malfunction of semiconductor products may happen. Hence, users are strongly recommended to comply with safety design including redundancy and fire-precaution equipments to prevent any accidents and fires that may follow.
8. Use of the information described herein for other purposes and/or reproduction or copying without the permission of HYCON Technology Corp. is strictly prohibited.

1. Brief Introduction

The use of the pricing scale involves the commercial trades so that its authentication standard is quite strict for making a fair trade between the buyer and the seller. Under all kinds of conditions, the measuring errors cannot exceed the permissible scope of the standard, or it may violate the fair dealing principle and cause many responsible questions in law. Therefore many countries have their standards on the commercial pricing scales and they need to obtain the national identification to be able to use in the trading market. In all standards, the OIML (International Organization of Legal Metrology) standard is the most complete one, so most countries in European and American use this standard as their criterion. For many countries in Asia, although they have their own authenticating standards, they also take OIML as the reference standard.

The pricing scale must pass OIML Class III authentication. The measuring error (ambient temperature $-10\sim 40^{\circ}\text{C}$) in the OIML authentication standard cannot exceed mpe_1 ($mpe=\text{max permissible error}$), and the systems that passed the authentication cannot exceed mpe_2 when are applied in the market, just like Figure 1. Table 1 shows the values of the biggest permissible error in each class when measuring.

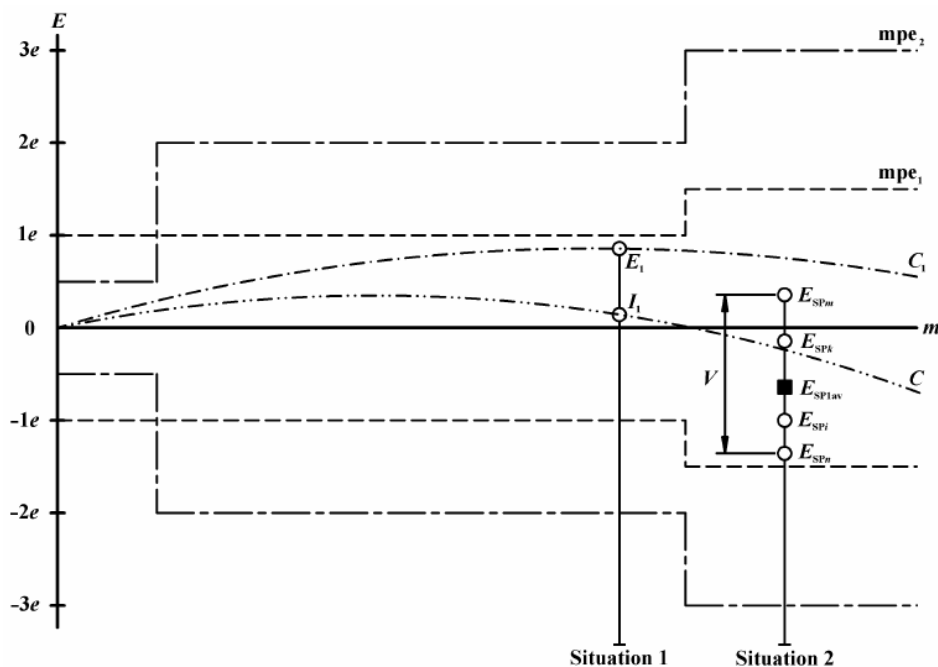

Figure 1

HY11P14

Application of the Pricing Scales that Adhere to OIML Standard



| Maximum permissible errors on initial verification | For loads, m , expressed in verification scale intervals, e | | | |
|--|---|-----------------------------|---------------------------|-----------------------|
| | Class I | Class II | Class III | Class IIII |
| $\pm 0.5 e$ | $0 \leq m \leq 50\,000$ | $0 \leq m \leq 5\,000$ | $0 \leq m \leq 500$ | $0 \leq m \leq 50$ |
| $\pm 1.0 e$ | $50\,000 < m \leq 200\,000$ | $5\,000 < m \leq 20\,000$ | $500 < m \leq 2\,000$ | $50 < m \leq 200$ |
| $\pm 1.5 e$ | $200\,000 < m$ | $20\,000 < m \leq 100\,000$ | $2\,000 < m \leq 10\,000$ | $200 < m \leq 1\,000$ |

Table 1

The most commonly used sensors for the electronic pricing scales are Load Cell. However, the Load Cell passed OIML authentication (Class C) has already taken P_{LC} (apportionment factor) ≤ 0.7 , such as Table 2, so the P_{LC} in the electronic equipments, such as ADC, should be smaller than **0.3**.

| mpe | Load, m | | | |
|-----------------------|---------------------------------|---------------------------------|-------------------------------|---------------------------|
| | Class A | Class B | Class C | Class D |
| $P_{LC} \times 0.5 v$ | $0 \leq m \leq 50\,000 v$ | $0 \leq m \leq 5\,000 v$ | $0 \leq m \leq 500 v$ | $0 \leq m \leq 50 v$ |
| $P_{LC} \times 1.0 v$ | $50\,000 v < m \leq 200\,000 v$ | $5\,000 v < m \leq 20\,000 v$ | $500 v < m \leq 2\,000 v$ | $50 v < m \leq 200 v$ |
| $P_{LC} \times 1.5 v$ | $200\,000 v < m$ | $20\,000 v < m \leq 100\,000 v$ | $2\,000 v < m \leq 10\,000 v$ | $200 v < m \leq 1\,000 v$ |

Table 2

2. Theory Description

Generally, the Load Cell passed OIML authentication will have some safety margins to assure P_{LC} (apportionment factor) ≤ 0.7 after being assembled into the scale and add-on the scale pan device. In Figure 2, E_{min} and E_{max} are the smallest and the largest load abilities of the Load Cell (Not assembled any devices or pans generally); D_{min} and D_{max} are the minimum and the maximum of Load Cell in applications (The finished product of an assembled scale generally.)

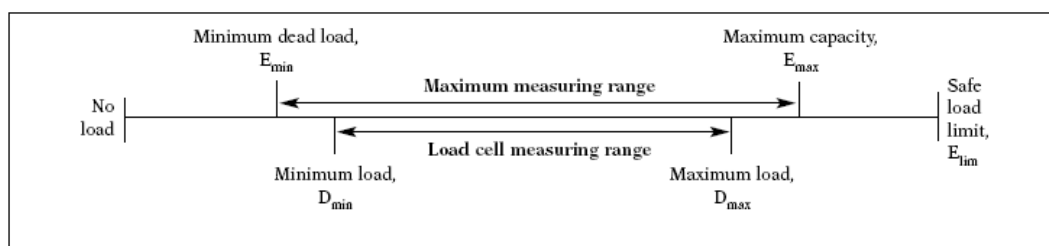

Figure 2

But D_{min} is possibly equal to E_{min} and D_{max} is possibly equal to E_{max} . To make sure the pricing scale be within the safe margin after assembling, we generally choose the larger weight of Load Cell to assemble according to the weight of the device or the pan. Suppose to assemble a 15Kg pricing scale, if the total weight of the device and the pan is 2Kg, the remaining Initial Zero range (20% of Max) will be about 3Kg, therefore, it is safer to choose 20Kg Load Cell to assemble the 15Kg pricing scale.

The testing items in the OIML standard include Titrating, Temperature, Power, Supply, Time, Creep, Zero Return, Durability and so on. To pass the authentication, these tests cannot exceed $mpe1$. Moreover, it uses $0.1e$ (verification scale interval) load on tests. So, it can satisfy the request to make a 3000 Count pricing scale only when its internal and external Count ratio achieves 10:1.

For all above mentioned, if we use a 20Kg Load cell that is passed the OIML authentication and the output rate = $2mV/V$ to assemble a 15Kg scale with 5g resolution, the electrical analysis is as follow on the overall standard of OIML Class III :

2.1. RMS Noise

If Load Cell voltage = 3V, the largest voltage of the signal output is:

$$(15Kg/20Kg) \times 2mV/V \times 3V = 4500000nV$$

Press 3000 Count pricing scale to figure out the smallest resolution voltage:

$$4500000nV \div (3000 \times 10) = 150nV$$

Therefore it can meet the demand when the largest RMS Noise of ADC is $150\text{nV} \div 3.3 \approx 45\text{nV}$.

2.2. Temperature

- ◆ The influence of the temperature to SPAN:

The OIML test range in ambient temperature is $-10^{\circ}\text{C} \sim +40^{\circ}\text{C}$. Within this range, the error of $0\text{g} \sim 500\text{g}$ cannot exceed $\pm 0.5\text{e}$, the one of $500\text{g} \sim 2000\text{g}$ cannot exceed $\pm 1\text{e}$ and the one of above 2000g cannot exceed $\pm 1.5\text{e}$.

Suppose Load Cell $P_{LC} = 0.7$, then the other electrical display device, such as ADC, can only assign to 0.3. The biggest error of $0\text{g} \sim 500\text{g}$ is $\pm 0.15\text{e}$, the one of $500\text{g} \sim 2000\text{g}$ is $\pm 0.3\text{e}$ and the one of above 2000g is $\pm 0.45\text{e}$.

Therefore, the temperature specification of ADC Span (Gain), $1000000 \times (0.45\text{e} \div 3000\text{e}) \div 30^{\circ}\text{C} = 5\text{ppm}/^{\circ}\text{C}$, is considered to calibrate in $15 \sim 20^{\circ}\text{C}$ ambient temperature, so the range of the largest temperature change is $\pm 30^{\circ}\text{C}$.

- ◆ The influence of the temperature to Offset Drift:

The OIML request for the influence of the temperature to the offset drift is that the temperature change cannot exceed 1e per 5°C .

Suppose Load Cell $P_{LC} = 0.7$, then the other electrical display device, such as ADC, can only assign to 0.3, that is, the temperature change cannot exceed 0.3e per 5°C .

Therefore, the temperature specification of ADC Offset Drift, $1000000 \times (0.3\text{e} \div 3000\text{e}) \div 5^{\circ}\text{C} = 20\text{ppm}/^{\circ}\text{C}$, that is $4500000\text{nV} \times 20\text{ppm}/^{\circ}\text{C} = 90\text{nV}$.

2.3. INL

In the OIML standard, the INL whose accuracy presents the whole linear error, can not exceed $\pm 0.25\text{e}$ at most. Load Cell P_{LC} has already taken 0.7, so the request for the ADC INL is $(0.25\text{e}) \times 0.3 = 0.075\text{e}$, that is approximately $\pm 25\text{ppm}$.

2.4. Software Display Request

2.4.1. Initial Zero

OIML limits that the Initial Zero cannot exceed 20% of the largest weight. To take the 15Kg pricing scale as an example, the initial zero cannot exceed 3Kg.

HY11P14

Application of the Pricing Scales that Adhere to OIML Standard

2.4.2. Zero Range

OIML limits that the Zero range (including Zero Tracking) cannot exceed 4% of the largest weight. To take the 15Kg pricing scale as the example, the Zero range (including Zero Tracking) cannot exceed 0.6Kg.

The limit of the Zero Tracking is that it cannot exceed $\text{Zero} \pm 0.25e$ per second and the Zero Tracking can be done only when the system is in the stable situation.

2.4.3. Tare

- ◆ Cannot Tare what is less than Zero.
- ◆ Need to display the "NET" or "Tare" symbol when Tare starts.
- ◆ Zero Tracking cannot enable when Tare starts.
- ◆ Tare enabled to the largest weight display
- ◆ Tare can be cancelled when it returns to $\text{Zero} \pm 0.25e$.

2.4.4. Change of Indication

When the weight changes, the system must display the changed weight within 1 second, that is, the ADC updating rate must be smaller than 1S.

2.4.5. Limits of indication

The largest display weight is the full scale $+9e$.

2.5. HY11P14 Specification

- ◆ ROM = 8K word
- ◆ RAM = 512 byte
- ◆ The influence of the temperature to ADC Gain: $5\text{ppm}/^\circ\text{C}$
- ◆ The influence of the temperature to ADC Offset Drift: $20\text{nV}/^\circ\text{C}$
- ◆ ADC INL = 20ppm
- ◆ ADC RMS Noise $40\text{nV} @ 1\text{Hz}$
- ◆ If take mpe1 as the authenticating specification, it must choose the Load Cell of $P_{LC} \leq 0.7$.

HY11P14

Application of the Pricing Scales that Adhere to OIML Standard

Load Cell Power is provided by VDDA. The Reference Voltage of HY11P14 ADC is connected to VDDA and VSS and enters through AI2 and AI3, and the Load Cell output voltage enters through AI0 and AI1.

When press the Power ON/OFF button, the Q3 will be conducted and U5 Regulator will output 3.3V to HY11P14 VDD. It takes 65mS for HY11P14 to make Power On Reset and then the program starts. At first, the system will set PT2.5 to Output High to keep U5 starting status through diode D1.

When the program is operating, it judges PT1.0 to be Low that means ON/OFF being pressed; it judges PT1.0 to be High that means ON/OFF being released so as to close PT2.5, and in the meantime, the U5 voltage output is 0. By this way, the system can achieve the ON/OFF function.

3.2. Low Battery

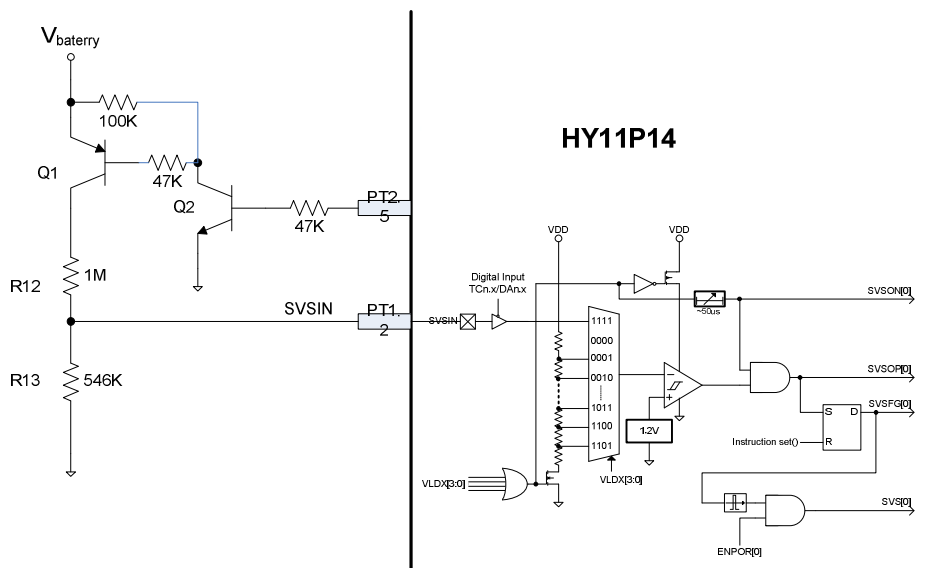

Figure 5

Due to the VDD power outputs by way of the Regulator, it is unable to use VDD to make low voltage detection. Therefore, the Battery voltage must pass through the differential voltage and input by PT1.2 (LVDIN) of 11P14 internal voltage management system.

When PT2.5 Output is High, the Battery voltage inputs LVDIN by way of the differential voltage of R12 and R13. If the LVDIN voltage is lower than 1.2V, the LVD flag of HY11P14 voltage management system will be 1 so that it can judge whether the battery voltage is low.

HY11P14

Application of the Pricing Scales that Adhere to OIML Standard



Because the internal ACM voltage reference of HY11P14 has the low temperature drift feature, if the system wants to judge the low voltage accurately, it has to choose the low-temperature coefficient resistors, like R12 or R13.

4. 50/60Hz Normal Mode Rejection

For HY11P14, the internal RC oscillator is 2MHz, the smallest Output Rate is 8Hz and the internal Comb Filter is SINC², its rejective effect to the 50/60Hz power is not good, so we suggest to take the external connected 4.9152Mhz Crystal to be the ADC reference frequency, and makes SINC³ Comb Filter with the software so that it may guarantee to achieve 95dB rejective effect against 50/60Hz ± 3Hz signals.

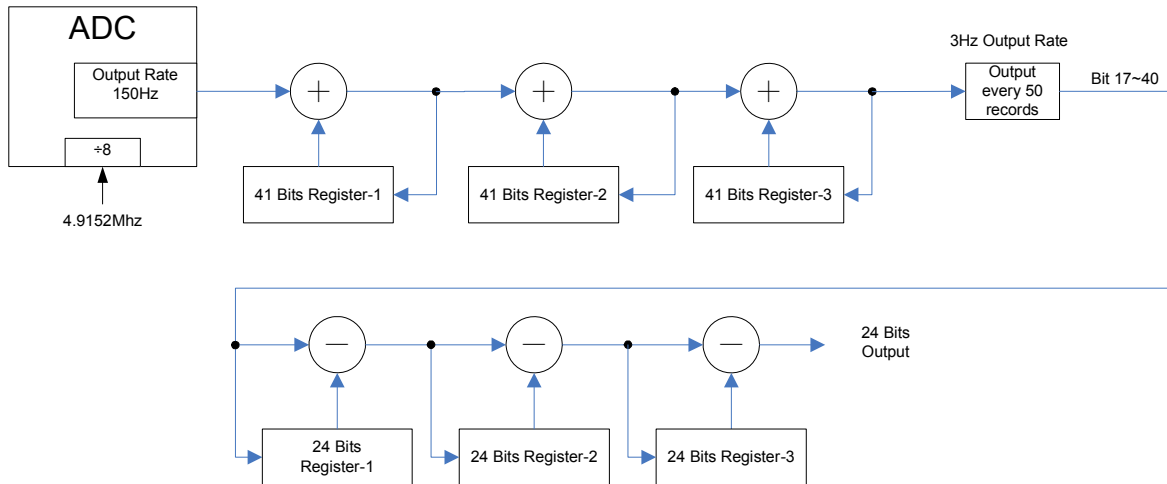

Figure 6

Figure 6 is the Comb Filter (SINC³) schematic by software. The ADC sampling frequency is to produce 307.2Khz sampling frequency from the external 4.9152Mhz Crystal differential frequency. For the ADC Output Rate, select it to be divided by 2048, then we can obtain 150Hz Output Rate. For the software Comb Filter, it must take 41 Bits in the integral part to make the operation. After operating 50 records, take the Bit 17~40 outputs to make differential processing, and finally output 24bits. The Output Rate is 3Hz.

Because the output is SINC³ Comb Filter, the stable output Data should be the 3rd record after changing the input signal.

As the software averages 50 records in the integral part and SINC³ output, the

accumulating buffer will $\left(\frac{\text{Log}_{50}}{\text{Log}_2}\right) \times 3 \cong 16.93$ Bits more, but it takes an integer to be 17Bits

during data processing so that the output data will reduce to $\left(\frac{2^{16.93}}{2^{17}}\right)$ of the original.

5. Software Function

5.1. Calibration Mode

After J4 being short circuit, press the system-on key S13 to make J4 be open circuit again, then the system will enter the calibration mode. LCD display shows as

Figure 7.

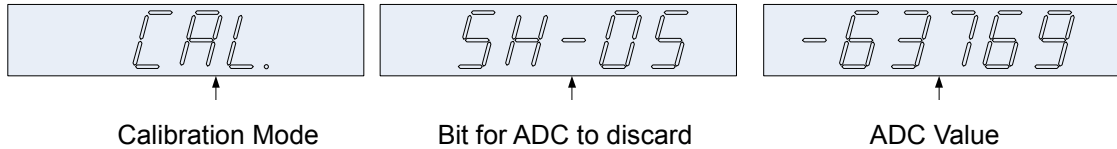
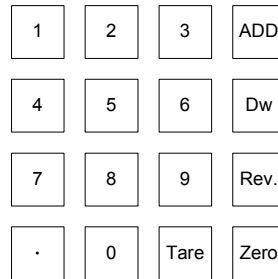

Figure 7



Key Function:

1. 0 ~ 9 → Number keys
2. ADD → Shift up or increase the records for ADC to discard
3. Dw → Shift down or reduce the records for ADC to discard
4. Rev. → Reserve
5. Zero → Return to zero
6. Tare → Tare key
7. . → Decimal point key or enter the calibration mode

(1) Set the Bit for ADC to Discard

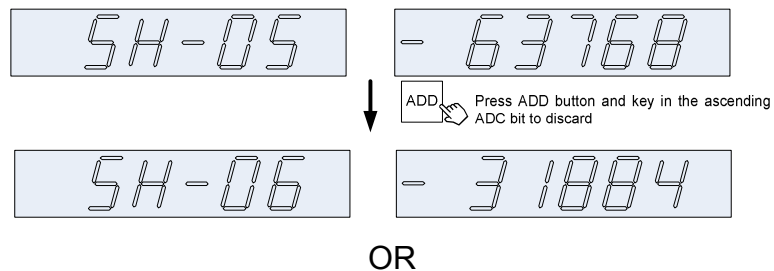

HY11P14

Application of the Pricing Scales that Adhere to OIML Standard

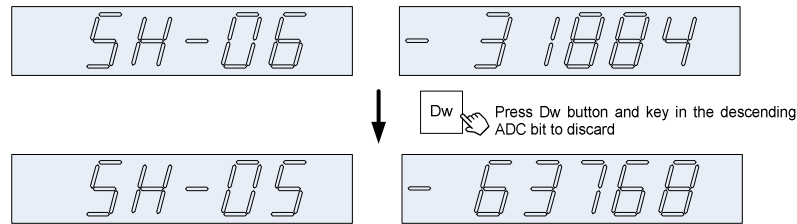

(2) Calibrating Procedure

For example, to produce a 15Kg pricing scale, the smallest resolution is 5g and the accuracy is 1/3000.

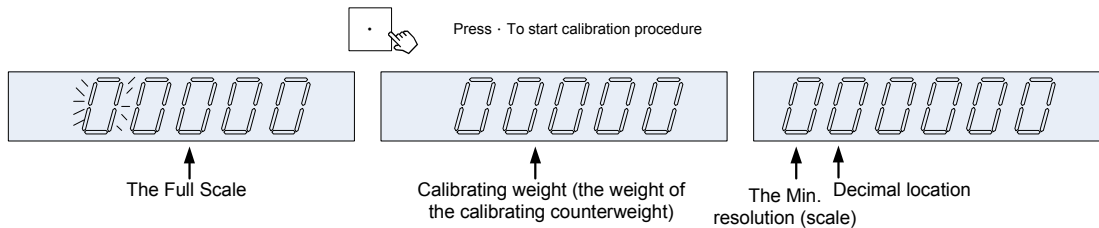

Enter the full scale (such as 15Kg).

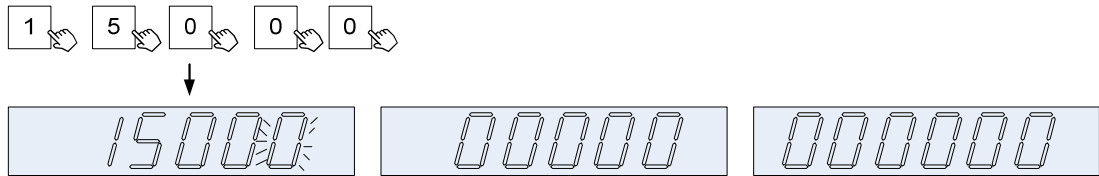

Enter the calibrating weight (such as to calibrate with 5kg counterweight).

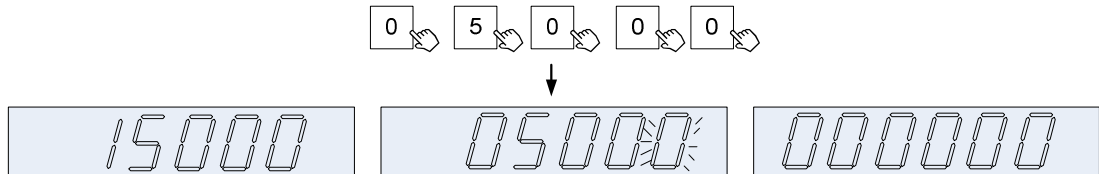

Input the smallest resolution and the decimal point location (such as the smallest resolution is 5g and the decimal point is located at the third).

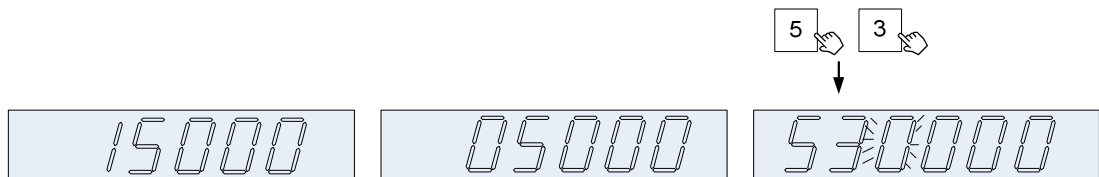

If found the wrong input, press **Dw** or **ADD** to return and input again.

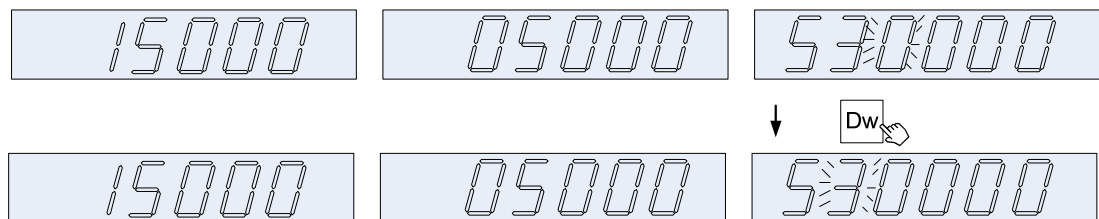

OR

HY11P14

Application of the Pricing Scales that Adhere to OIML Standard

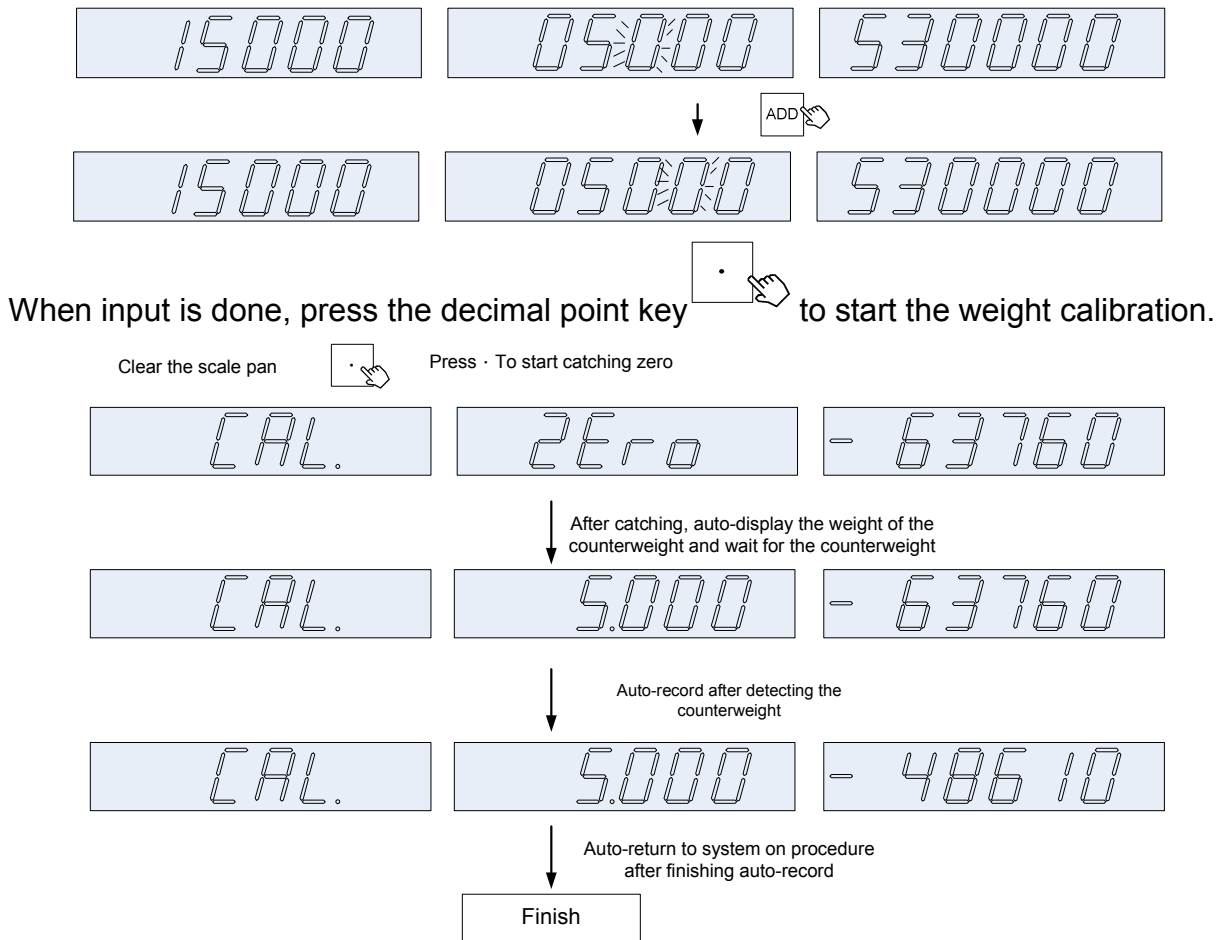

5.2. The Pricing Mode

When the calibration is complete or already calibrated (there is the calibrated data in EEPROM), the system will enter a starting procedure at first, the starting procedure may examine LCD whether it has breaking characters or other questions, and may warm the system up in this period of time.

If the initial zero drifts above $\pm 10\%$ ($\pm 1.5\text{Kg}$) of the full scale, it displays

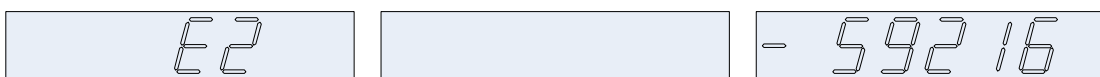

Enter the scale pricing mode after finishing the start countdown. It shows as Figure 8.

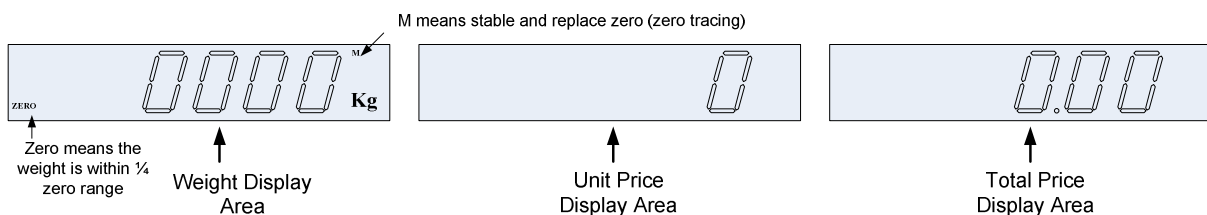

Figure 8

HY11P14

Application of the Pricing Scales that Adhere to OIML Standard

1. Input the Unit Price

Input the number keys 0~9 or the decimal point that they display in the unit price area.

For example, to input 36.58 dollars:

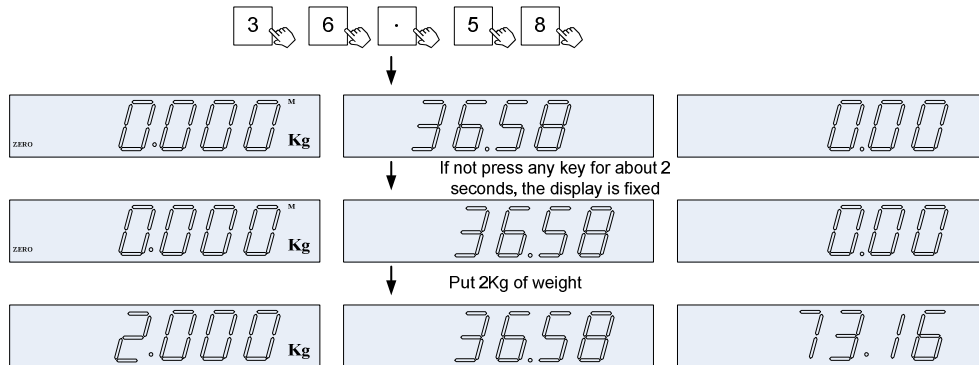

For the negative weight, it displays

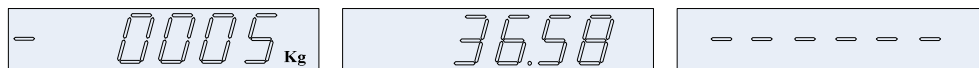

If the weight exceeds the full scale +9d, it displays

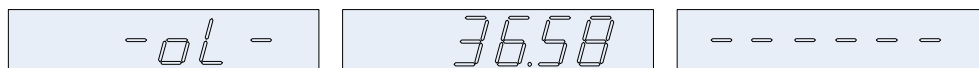

2. Zero

When the weight on the scale pan is smaller than $\pm 3\%$ ($\pm 450g$) of the full scale, it can make Zero.

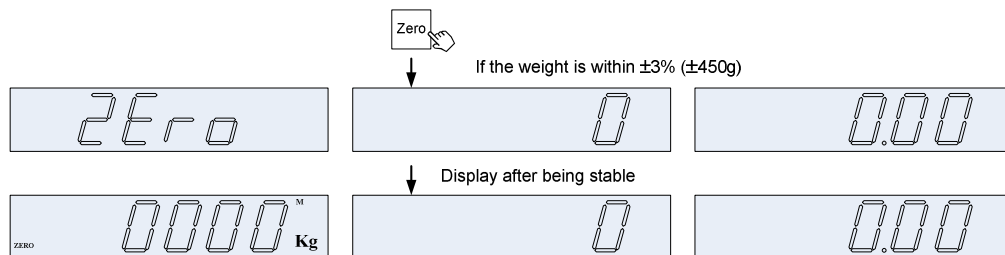

3. Tare

When the weight on the scale pan is smaller than the full scale +9d, it can make Tare. If the weight exceeds the range of zero $\pm 1/4d$, it cancels the zero tracing function and displays the Tare symbol.

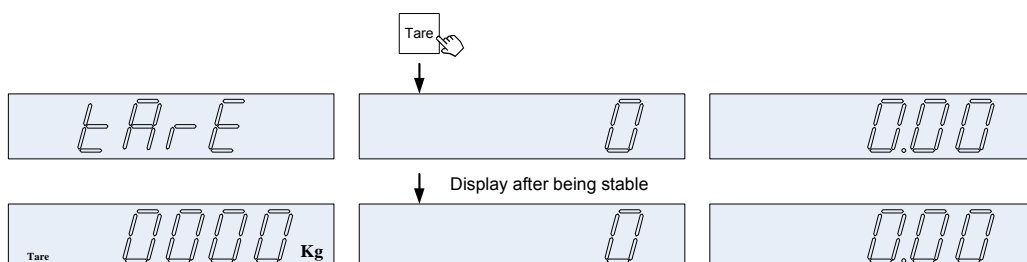

HY11P14

Application of the Pricing Scales that Adhere to OIML Standard



When the Tare returns to the range of zero $\pm 1/4d$, it cancels the Tare symbol and then displays the zero symbol and starts the zero tracing function.

6. Testing Forms

According to OIML measuring items, we make the following tests.

6.1. Discrimination

| | At start | At max | At end | |
|-------------|----------|--------|--------|-----|
| Temp.: | | | | °C |
| Rel. h.: | | | | % |
| Time: | | | | |
| Bar. pres.: | | | | hPa |

(only class I)

| Load, L | Indication, I_1 | Removed load ΔL | Add 1/10 d | Extra load, $= 1.4 d$ | Indication, I_2 | $I_2 - I_1$ |
|--------------|----------------------|-------------------------------|-----------------|-----------------------------|----------------------|-------------|
| | | | | | | |
| | | | | | | |
| | | | | | | |

Check if $I_2 - I_1 \geq d$

Passed

Failed

HY11P14

Application of the Pricing Scales that Adhere to OIML Standard



6.3. Zero Return

| | At start | At max | At end | |
|-------------|----------|--------|--------|-----|
| Temp.: | | | | °C |
| Rel. h.: | | | | % |
| Time: | | | | |
| Bar. pres.: | | | | hPa |

(only class I)

Automatic zero-setting and zero-tracking device is:

- Non-existent
 In operation
 Out of working range

$$P = I + \frac{1}{2} e - \Delta L$$

| Time of reading | Load, L_0 | Indication of zero, I_0 | Add. load, ΔL | P |
|-----------------|-------------|---------------------------|-----------------------|---------|
| 0 min | | | | $P_0 =$ |

Load during 30 minutes =

| | | | | |
|--------|--|--|--|------------|
| 30 min | | | | $P_{30} =$ |
|--------|--|--|--|------------|

Change after 30 minutes: $|\Delta(P_{30} - P_0)| =$

| | | | | |
|--------|--|--|--|------------|
| 35 min | | | | $P_{35} =$ |
|--------|--|--|--|------------|

Change after 35 minutes: $|\Delta(P_{35} - P_{30})| =$

- Check if
- a) $|\Delta(P_{30} - P_0)| \leq 0.5 e$
 - b) $|\Delta(P_{35} - P_{30})| \leq e_1$ (for multiple range instruments only)

- Passed
 Failed

HY11P14

Application of the Pricing Scales that Adhere to OIML Standard



6.4. Creep

| | At start | At max | At end | |
|-------------|----------|--------|--------|-----|
| Temp.: | | | | °C |
| Rel. h.: | | | | % |
| Time: | | | | |
| Bar. pres.: | | | | hPa |

(only class I)

$$P = I + \frac{1}{2} e - \Delta L$$

| Time of reading | | Load, L | Indication, I | Add. load, ΔL | P | ΔP |
|-----------------|---------|---------|---------------|---------------|---|----|
| | 0 min | | | | | |
| | 5 min | | | | | |
| | 15 min | | | | | |
| | 30 min* | | | | | |

| | | | | | | |
|--|-----|--|--|--|--|--|
| | 1 h | | | | | |
| | 2 h | | | | | |
| | 3 h | | | | | |
| | 4 h | | | | | |

ΔP = difference between P at the start (0 min) and P at a given time.

* If condition a) is met, the test is terminated. If not, the test shall be continued for the next 3.5 hours and condition b) shall be met.

Condition a): $\Delta P \leq 0.5 e$ after 30 minutes; and $\Delta P \leq 0.2 e$ between the indication obtained at 15 minutes and that at 30 minutes

Condition b): $\Delta P \leq$ absolute value of mpe during the period of 4 hours Check if condition a) or b) is fulfilled

Passed Failed

HY11P14

Application of the Pricing Scales that Adhere to OIML Standard



6.5. Stability of Equilibrium

| | At start | At max | At end | |
|-------------|----------|--------|--------|-----|
| Temp.: | | | | °C |
| Rel. h.: | | | | % |
| Time: | | | | |
| Bar. pres.: | | | | hPa |

(only class I)

Automatic zero-setting and zero-tracking device is:

- Non-existent Not in operation Out of working range In operation

In the case of printing or data storage:

| No. | Load (about 50 % of Max) | First printed or stored weight value after disturbance and command | Reading during 5 s after print-out or storage | |
|-----|-----------------------------|---|---|---------------|
| | | | minimum value | maximum value |
| 1 | | | | |
| 2 | | | | |
| 3 | | | | |
| 4 | | | | |
| 5 | | | | |

Check if the first printed or stored weight value does not deviate more than 1 e from the readings during 5 seconds after print-out or storage (only two adjacent values allowed)

- Passed Failed

In the case of zero-setting or tare balancing:

| Zero-setting $E_0 = I_0 + \frac{1}{2} e - \Delta L - L_0$ | | | | | |
|---|-----------------------------|----------------------------|---|-----------------------|--------------|
| No. | Zero-load (< 4 % of Max) | Load, L_0^{**} (10 e) | Indication, I_0 after zero-setting | Add. load, ΔL | Error, E_0 |
| 1 | | | | | |
| 2 | | | | | |
| 3 | | | | | |
| 4 | | | | | |
| 5 | | | | | |

| Tare balancing $E_0 = I_0 + \frac{1}{2} e - \Delta L - L_0$ | | | | | |
|---|-----------------------------|----------------------------|---|-----------------------|--------------|
| No. | Tare-load (< 4 % of Max) | Load, L_0^{**} (10 e) | Indication, I_0 after zero-setting | Add. load, ΔL | Error, E_0 |
| 1 | | | | | |
| 2 | | | | | |
| 3 | | | | | |
| 4 | | | | | |
| 5 | | | | | |

* Apply the zero or tare load, disturb the equilibrium and immediately release zero-setting or tare, apply L_0 if necessary and calculate the error according to A.4.2.3/A.4.6.2 of R 76-1. Perform this five times.

** L_0 (10 e) shall be applied only if an automatic zero-setting or zero-tracking device is in operation. L_0 shall be applied after releasing tare or zero-setting, immediately after zero is displayed the first time.

- Check if $E_0 \leq 0.25 e$ Passed Failed

HY11P14

Application of the Pricing Scales that Adhere to OIML Standard



6.6. Repeatability

| | At start | At max | At end | |
|-------------|----------|--------|--------|-----|
| Temp.: | | | | °C |
| Rel. h.: | | | | % |
| Time: | | | | |
| Bar. pres.: | | | | hPa |

(only class I)

Automatic zero-setting and zero-tracking device is:

- Non-existent In operation

Load (weighing 1-10)

Load (weighing 11-20)

$$E = I + 1/2 e - \Delta L - L$$

| | Indication of load, I | Add. load, ΔL | E |
|----|-----------------------|-----------------------|---|
| 1 | | | |
| 2 | | | |
| 3 | | | |
| 4 | | | |
| 5 | | | |
| 6 | | | |
| 7 | | | |
| 8 | | | |
| 9 | | | |
| 10 | | | |

| | Indication of load, I | Add. load, ΔL | E |
|----|-----------------------|-----------------------|---|
| 11 | | | |
| 12 | | | |
| 13 | | | |
| 14 | | | |
| 15 | | | |
| 16 | | | |
| 17 | | | |
| 18 | | | |
| 19 | | | |
| 20 | | | |

$E_{\max} - E_{\min}$ (weighing 1-10)

$E_{\max} - E_{\min}$ (weighing 11-20)

mpe

mpe

Check if a) $E \leq mpe$ (3.6 of R 76-1)

b) $E_{\max} - E_{\min} \leq$ absolute value of mpe (3.6.1 of R 76-1)

- Passed Failed

HY11P14

Application of the Pricing Scales that Adhere to OIML Standard



6.7. Tare

| | At start | At max | At end | |
|-------------|----------|--------|--------|-----|
| Temp.: | | | | °C |
| Rel. h.: | | | | % |
| Time: | | | | |
| Bar. pres.: | | | | hPa |

(only class I)

Automatic zero-setting and zero-tracking device is:

- Non-existent
 Not in operation
 Out of working range
 In operation

$$E = I + \frac{1}{2} e - \Delta L - L$$

$$E_c = E - E_0 \text{ with } E_0 = \text{error calculated at or near zero}^*$$

| Load, L | Indication, I | | Add. load, ΔL | | Error, E | | Corrected error, E _c | | mpe |
|----------------------|---------------|---|---------------|---|----------|---|---------------------------------|---|-----|
| | ↓ | ↑ | ↓ | ↑ | ↓ | ↑ | ↓ | ↑ | |
| Fast tare load | | | | | | | | | |
| <input type="text"/> | | | | | | | | | |
| | | | | | | | | | |
| | | | | | | | | | |
| | | | | | | | | | |
| | | | | | | | | | |
| | | | | | | | | | |
| | | | | | | | | | |

| | | | | | | | | | |
|----------------------|--|--|--|--|--|--|--|--|--|
| Second tare load | | | | | | | | | |
| <input type="text"/> | | | | | | | | | |
| | | | | | | | | | |
| | | | | | | | | | |
| | | | | | | | | | |
| | | | | | | | | | |
| | | | | | | | | | |
| | | | | | | | | | |

Check if $|E_c| \leq |mpe|$

- Passed
 Failed

HY11P14

Application of the Pricing Scales that Adhere to OIML Standard

7. Demo Code



HY11P14-OIML
Price Scale.rar