



HY12S65

HY-IDE Hardware User Manual

Table of Contents

1. HY-IDE STRUCTURE	4
2. HY-IDE USB CONTROL BOARD.....	5
2.1. Diagram.....	5
2.2. Circuit Description	6
3. HY-IDE ICE BOARD	7
3.1. Diagram.....	7
3.2. Circuit Description	8
3.3. Circuit	17
4. SIMPLE ERROR DETECTION	18
4.1. ICE cannot connect to software	18
4.2. Program Memory Loading Error	21
5. REVISION HISTORY	23

Attention :

1. HYCON Technology Corp. reserves the right to change the content of this datasheet without further notice. For most up-to-date information, please constantly visit our website:
<http://www.hycontek.com> .
2. HYCON Technology Corp. is not responsible for problems caused by figures or application circuits narrated herein whose related industrial properties belong to third parties.
3. Specifications of any HYCON Technology Corp. products detailed or contained herein stipulate the performance, characteristics, and functions of the specified products in the independent state. We does not guarantee of the performance, characteristics, and functions of the specified products as placed in the customer's products or equipment. Constant and sufficient verification and evaluation is highly advised.
4. Please note the operating conditions of input voltage, output voltage and load current and ensure the IC internal power consumption does not exceed that of package tolerance. HYCON Technology Corp. assumes no responsibility for equipment failures that resulted from using products at values that exceed, even momentarily, rated values listed in products specifications of HYCON products specified herein.
5. Notwithstanding this product has built-in ESD protection circuit, please do not exert excessive static electricity to protection circuit.
6. Products specified or contained herein cannot be employed in applications which require extremely high levels of reliability, such as device or equipment affecting the human body, health/medical equipments, security systems, or any apparatus installed in aircrafts and other vehicles.
7. Despite the fact that HYCON Technology Corp. endeavors to enhance product quality as well as reliability in every possible way, failure or malfunction of semiconductor products may happen. Hence, users are strongly recommended to comply with safety design including redundancy and fire-precaution equipments to prevent any accidents and fires that may follow.
8. Use of the information described herein for other purposes and/or reproduction or copying without the permission of HYCON Technology Corp. is strictly prohibited.

1. HY-IDE Structure

HY-IDE (HYCON - Integrated Development Environment) is composed by USB Control Board, ICE Board and Target Board that can emulate function and performance of HY12P series products. Through PC connection, HY-IDE can carry out emulation, debugging, program...etc. function as illustrated in Figure 1.

The actual connection way of HY-IDE boards to HY-IDE software can be referred to below Figure1-1

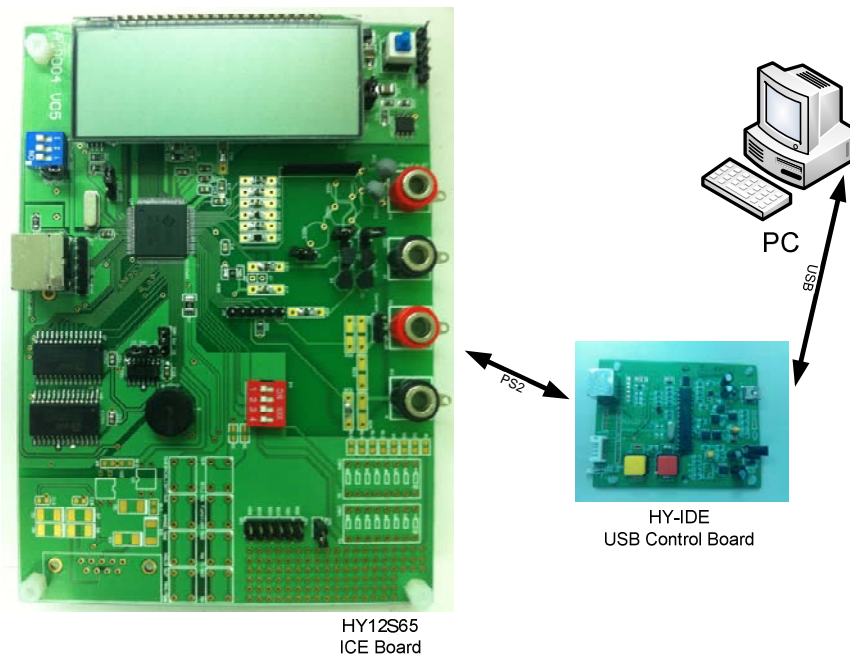

Figure 1

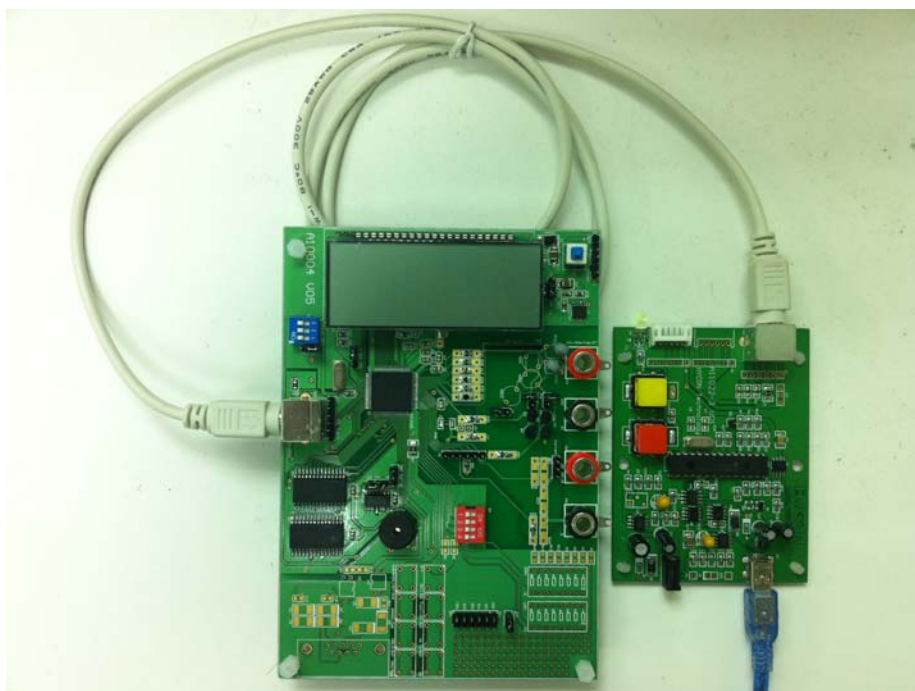

Figure 1-1

2. HY-IDE USB Control Board

2.1. Diagram

HY-IDE USB control board is the bridge that connects PC and HY-IDE ICE Board. Users can emulate HY11P Series products' function and implement programming OTP products in the engineering stage by the control board, as shown in Figure 2.

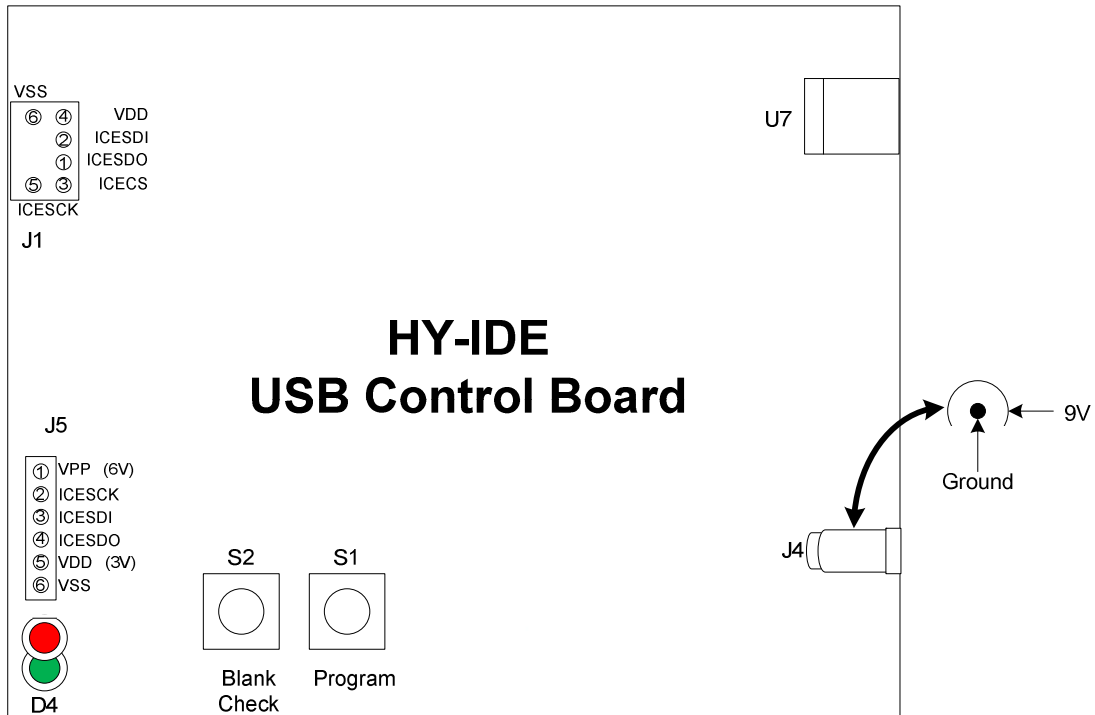

Figure 2

2.2. Circuit Description

Ports description of Figure 2 :

◆ J4 : Adapter 9V input

The internal is negative and the external is positive, providing programming power source (must be connected while OTP programming).

◆ U7 : USB connector to PC port

Download program for emulation debug function

Download programming program for HY12P Series products

◆ J1 : HY-ICE Board control port

PIN 1 ICESDO connects to ICE_SDO of HY12S65

PIN 2 ICESDI connects to ICE_SDI of HY12S65

PIN 3 ICESCS connects to ICE_CS of HY12S65

PIN 4 VDD connects to ICE_VCC of HY12S65

PIN 5 ICESCK connects to ICE_SCK of HY12S65

PIN 6 VSS connects to ICE_VSS of HY12S65

◆ J5 : HY12P series programming control port

PIN 1 VPP (6V) connects to VPP of the IC

PIN 2 ICECK connects to PSCK of the IC

PIN 3 ICESDI connects to PSDI of the IC

PIN 4 ICESDO connects to PSDO of the IC

PIN 5 VDD (3V) connects to VDD of the IC

PIN 6 VSS connects to VSS of the IC

◆ S1 : IC Programming key

◆ S2 : IC Blank Check key

◆ D4 : Two color LED ;

Red LED: OTP programming, Blank Check...failure signal.

Green LED: OTP programming, Blank Check...success signal.

Green LED: USB/Adapter power-on signal.

HY12S65 HY-IDE Hardware User Manual

3. HY-IDE ICE Board

3.1. Diagram

HY-IDE ICE Board is the chip board of HY12S65. Its main function is to implement emulation of HY12P Series Products. This ICE chip can directly emulate HY12P6X Series. HY-IDE ICE Board DK02 is shown in below Figure 3.

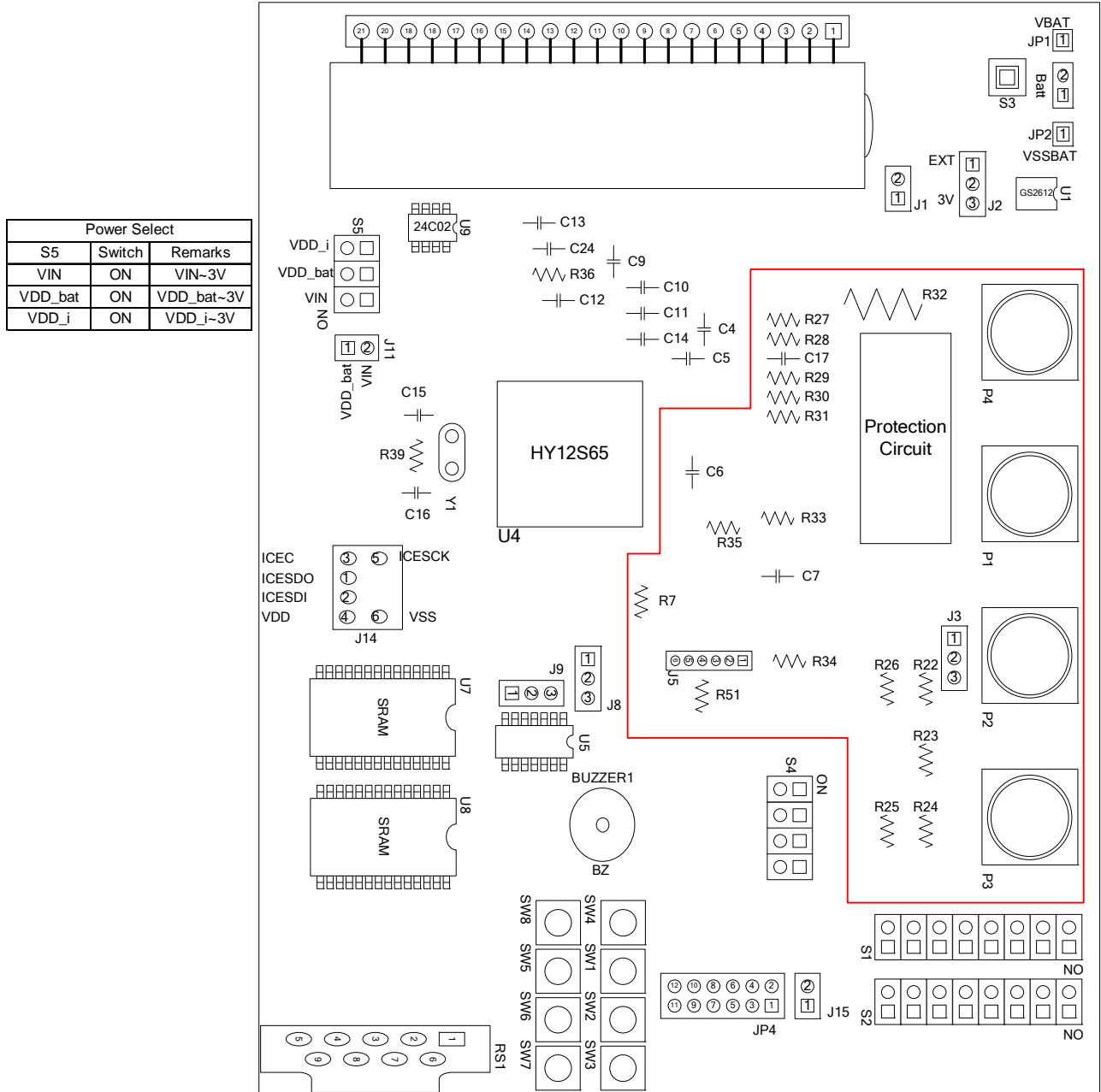

Figure 3

3.2. Circuit Description

Below is the description of Figure 3 connector:

- ◆ J14: Connects to J1 PS2 communication port of HY-IDE USB Control Board. PC gives commands to HY12S65 through Control Board. It can download program to SRAM and can perform single execution, Free RUN...etc. debugging functions.
- ◆ S5: ICE board power selection (voltage from USB Control Board)
VIN -When switched to ON, it represents VIN~3V voltage.
VDD_bat - when switched to ON, it represents VDD_bat~3V voltage.
VDD_i - when switched to ON, it represents VDD_i~3V voltage.
- ◆ Setup Ways of Power Selection :
PC can supply power to ICE Board via USB or from external power sources.
When it is powered by USB, the switches of S5 VIN and VDD_bat must turn to ON
When it is powered by external power source, it must be connected though HY-IDE ICE Board Batt (JP1/JP2) and the switch of VDD_bat and VDD_i must be turned to OFF.
- ◆ J11: Can set up whether to short VIN and VDD_bat
- ◆ U7 & U8: SRAM
- ◆ J1 & J2: Program capacity selection of IC emulation chip
HY12S65 ROM Size is 16k Word (32K Byte), thus when HY12S65 is chosen, J8 PIN 1-2 and J9 PIN 1-2 must be shorted
When using HY12P series that has 8K Word (16K Byte) ROM Size or under, J8 PIN 2-3 and J9 PIN 2-3 must be shorted
- ◆ Y1, R39, C15 and C16 : connects to external crystal and peripheral capacitors and resistors
- ◆ C24: VDD power input regulated capacitor is recommended to keep in between 1uF to 10uF
- ◆ C13: VLCD power output regulated capacitor is recommended to keep in between 1uF ~ 4.7uF
- ◆ C4, C5, C10, C11, C12, C13 and C14: Analog power regulated capacitor
In order to enhance the operation performance of ADC, the regulated capacitor is suggested to locate as closer to the pin as possible.
C4 : REFO-AGND capacitor: 100nF
C5 : AGND capacitor: 100nF
C10 : VGG capacitor: 1uF
C11 : VDDA capacitor: 1uF
C12 : CA & CB capacitor: 100nF
C13 : VLCD capacitor: 1uF
C14 : ACM capacitor: 100nF

◆ Power system :

ICE power system can be supply by 3V regulated power of HY-IDE USB Control Board or by external input power (**the external power input cannot exceed 3.6V as the datasheet specified**). When ICE emulates, it only need to connect U7 USB of HY-IDE USB Control Board to PC end to supply ICE power. USB power and external power will be introduced in below:

■ USB power :

When using USB power supply, VDD_bat and VDD_i switch of HY-IDE ICE Board S5 must be turned to ON so that ICE can be powered by 3V USB regulated voltage.

To measure IC consumption current, the switch must configure VIN and VDD_bat to ON and power by USB regulated 3V and measure the current consumption from J1 of HY-IDE ICE Board.

■ External Power :

Users must be careful when using external power, the VIN, VDD_bat and VDD_i option of S5 switch of HY-IDE ICE Board must be switched to OFF status first.

External power can be input from JP1 VBAT positive end, VSSBAT negative end of HY-IDE ICE Board and S3 is the power on/off control.

◆ J2: power select (whether the system power passes through Regulator (U1))

J2 PIN 1-2 short means, inputting VBAT external power input to U1, supplying the whole system regulated 3V power from VDD_i (to change output voltage, R40, R41 & R42, its equation is:

$$V_{OUT} = 1.240V \times \left(1 + \frac{R40 + R41}{R42}\right)$$

J2 PIN 2-3 short means, VBAT power directly input to VDD_i (**the external power input cannot exceed 3.6V as the datasheet specified**).

◆ J1: Can connect to current meter, testing the whole VDD_i current consumption. It must be shorted if current meter was not connected, VDD_bat voltage will equals to that of VDD_i, as shown in Figure 4.

◆ **Users must pay attention that** VDD_bat voltage will equal to VDD_i voltage when J1 short. If using external power, then VIN, VDD_bat and VDD_i options of S5 switch must be switched to OFF status to continue the following operations as to prevent hardware damage resulted from power backflow of HY-IDE USB Control Board, showing in Figure 4.

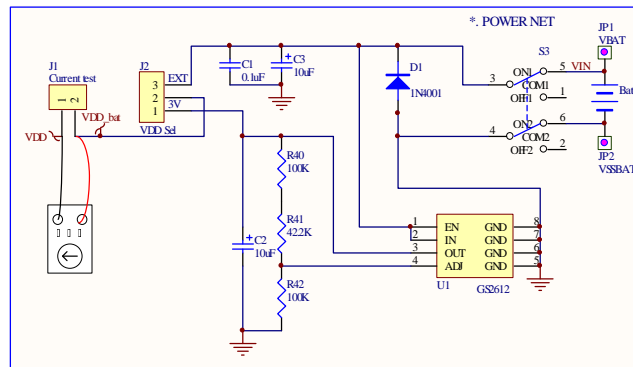

Figure 4

- ◆ RST Circuit : Please refer to Figure 5 in below.

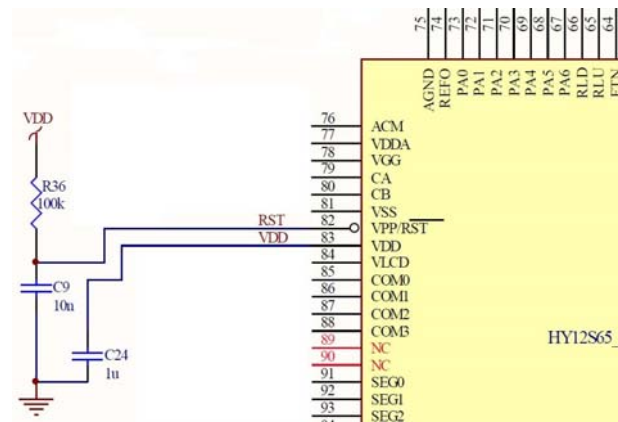

Figure 5

- ◆ JP4: SPI communication port, as shown in Figure 6.

PIN1	VDD
PIN2	PT1.2 (SDI)
PIN3	PT1.6 (SCK)
PIN4	PT1.5 (SDO)
PIN5	PT1.1 (CS)
PIN6	VSS

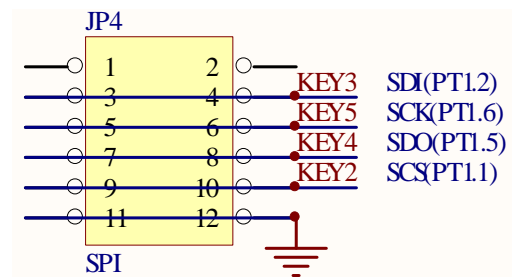

Figure 6

- ◆ RS1 : UART communication port (RS232). Commonly use 9-PIN female header, as shown in Figure 7.

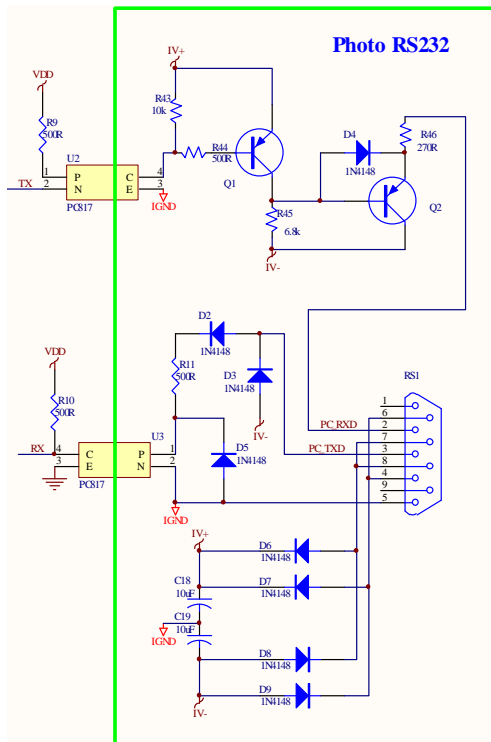

Figure 7

- ◆ BUZZER1 : Buzzer, connects to JUMP as PT1.7 signal as Figure 8 illustrated.

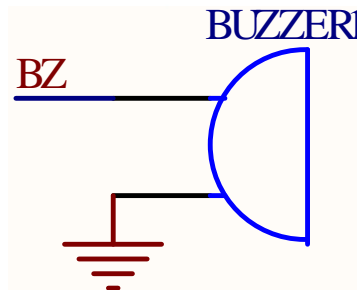

Figure 8

- ◆ U9 : EEPROM 24C02, as described in Figure 9.

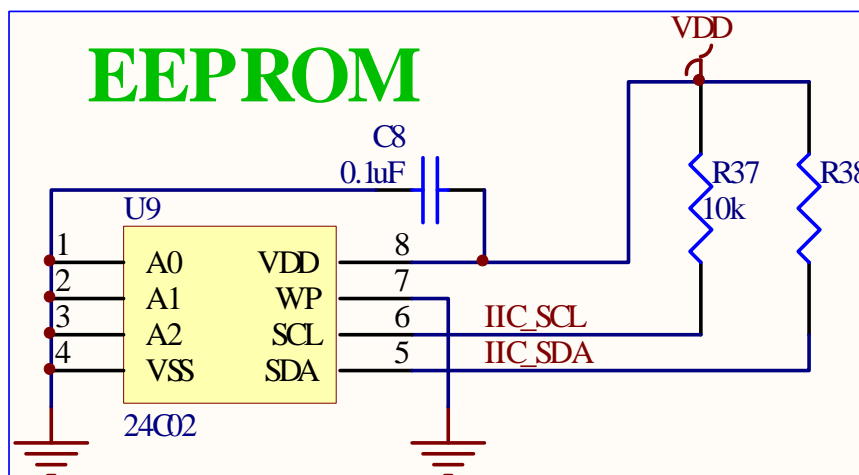

Figure 9

HY12S65 HY-IDE Hardware User Manual

◆ J10, JP3 : LCD pin, as shown in Figure 10.

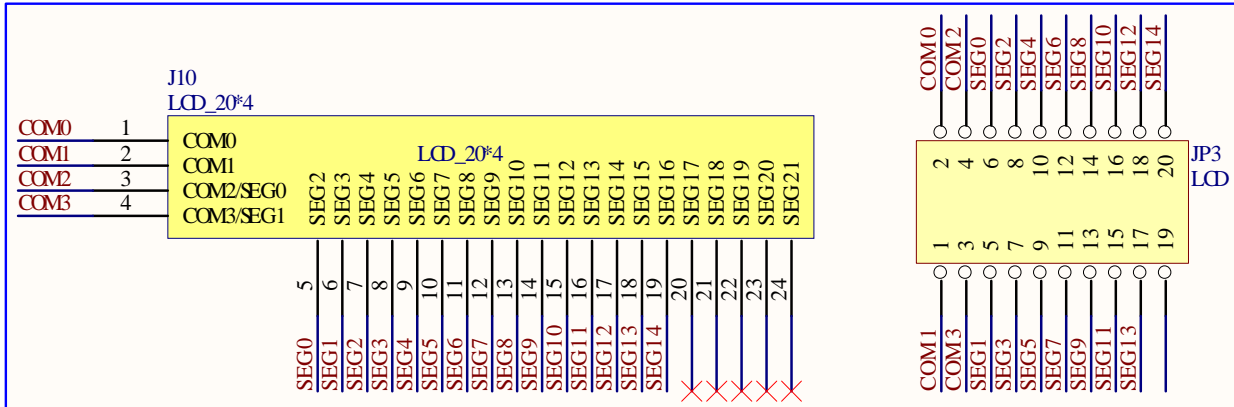

Figure 10

The LCD specification of HY-IDE ICE Board is molded by HYCON, LCD symbols and pins are depicted in Figure 11 and Figure 12.

LCD detailed specifications are as follows:

Operation voltage : 3.0V

Visible angle : 60°

Operation frequency : 60Hz

Bias : 1/3 bias

Waveform : 1/4 duty

Pin : 90 degree

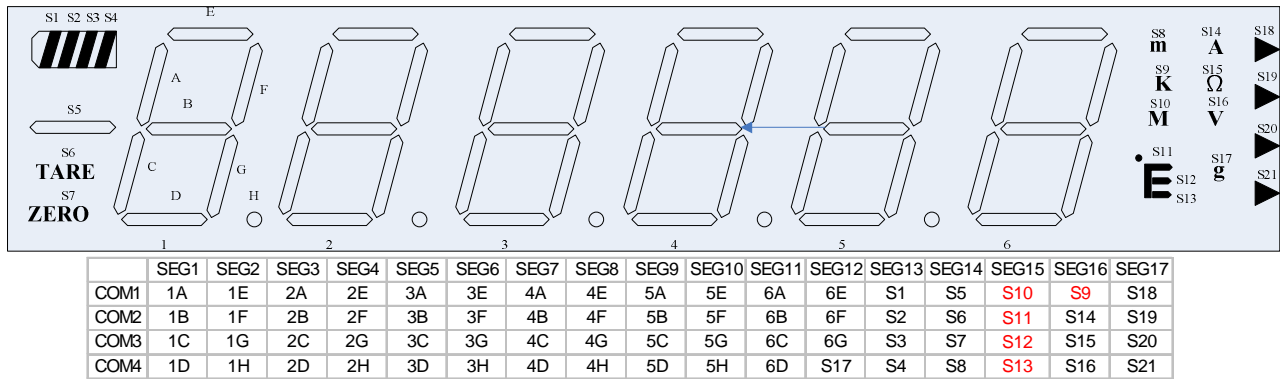
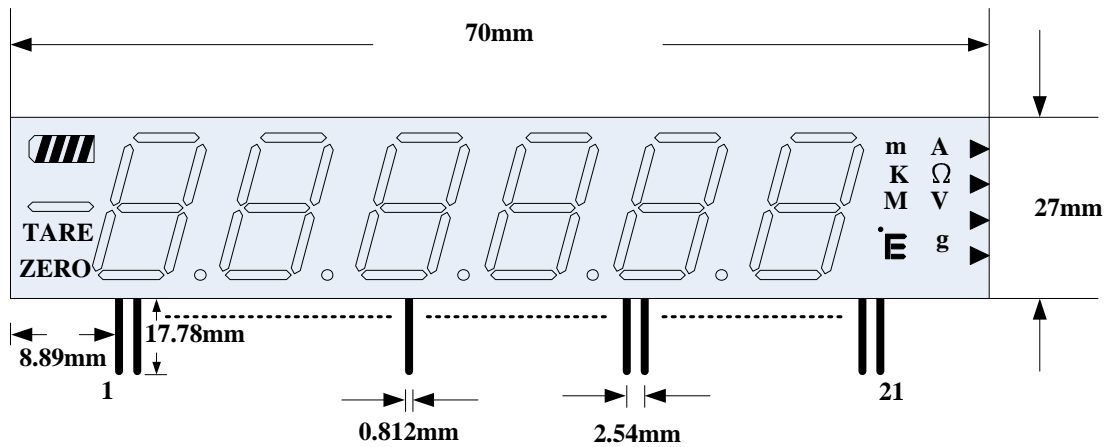

Figure 11

HY12S65 HY-IDE Hardware User Manual



PIN	1	2	3	4	5	6	7	8	9	10	11
I/O	COM1	COM2	COM3	COM4	SEG1	SEG2	SEG3	SEG4	SEG5	SEG6	SEG7
PIN	12	13	14	15	16	17	18	19	20	21	
I/O	SEG8	SEG9	SEG10	SEG11	SEG12	SEG13	SEG14	SEG15	SEG16	SEG17	

Figure 12

- ◆ Y1, C15 and C16: connects to external Crystal oscillation circuit, as shown in Figure 13.
HY-IDE ICE Board already connects to Y1-4MHZ oscillator for user application.

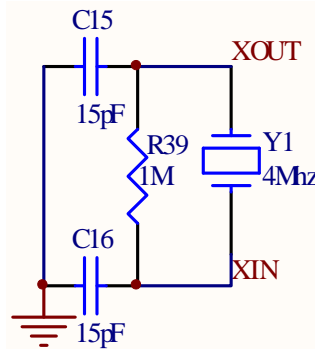

Figure 13

- ◆ SW1, SW2, SW3, SW4, SW5, SW6, SW7 & SW8 : Can use KEY1~KEY6 to carry out 8 sets key scan, as shown in Figure 14.

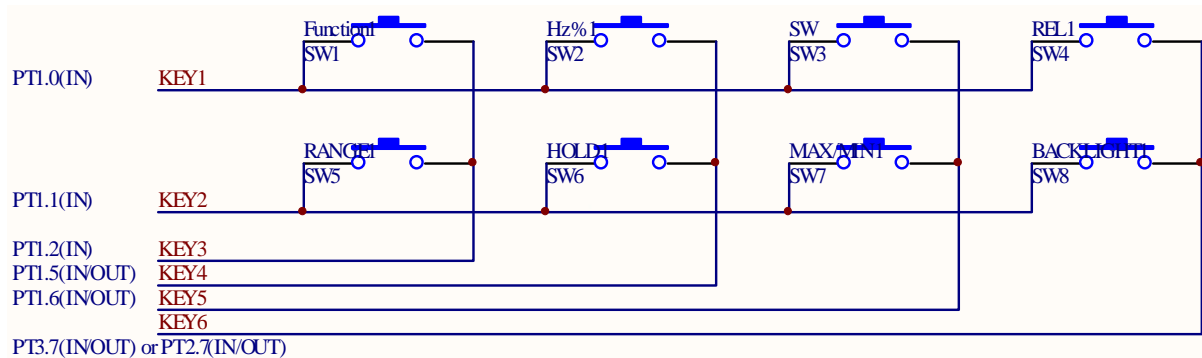

Figure 14

- ◆ S4 : Function switch pin for PT2.4~PT2.7, as shown in Figure 15.

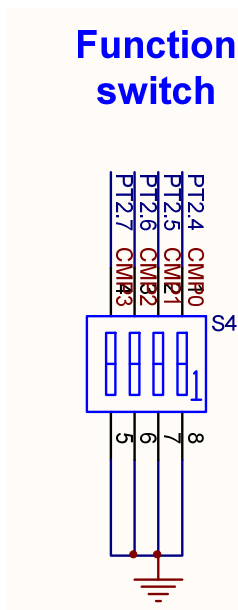

Figure 15

- ◆ S1 and S2 : Divided by resistors (R1~R4 · R12~R15), using comparator to form 16 sets key scan.

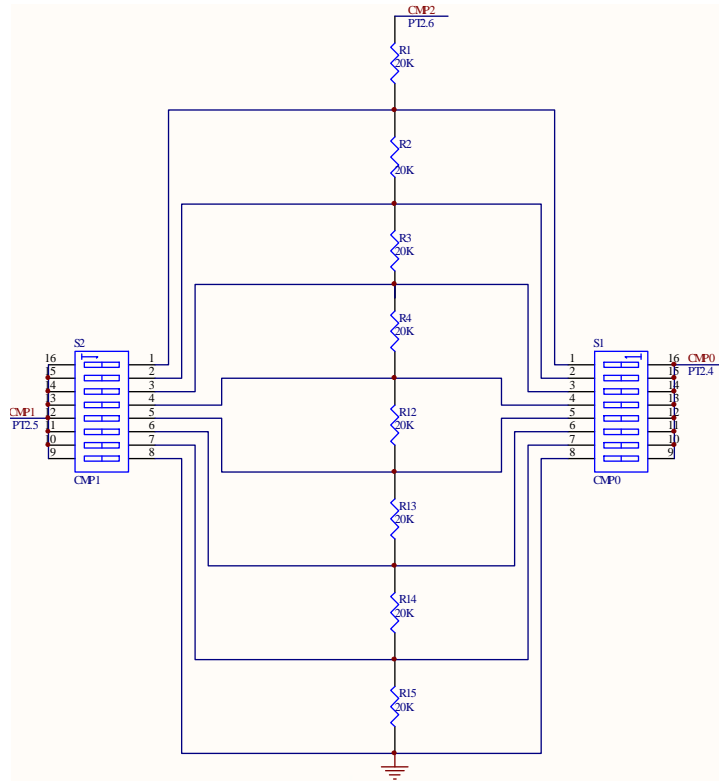

Figure 16

- ◆ Digital Multi-meter (DMM) application measurement circuit: shown in Figure 17 (the diagram is circled in red as in Figure 3).

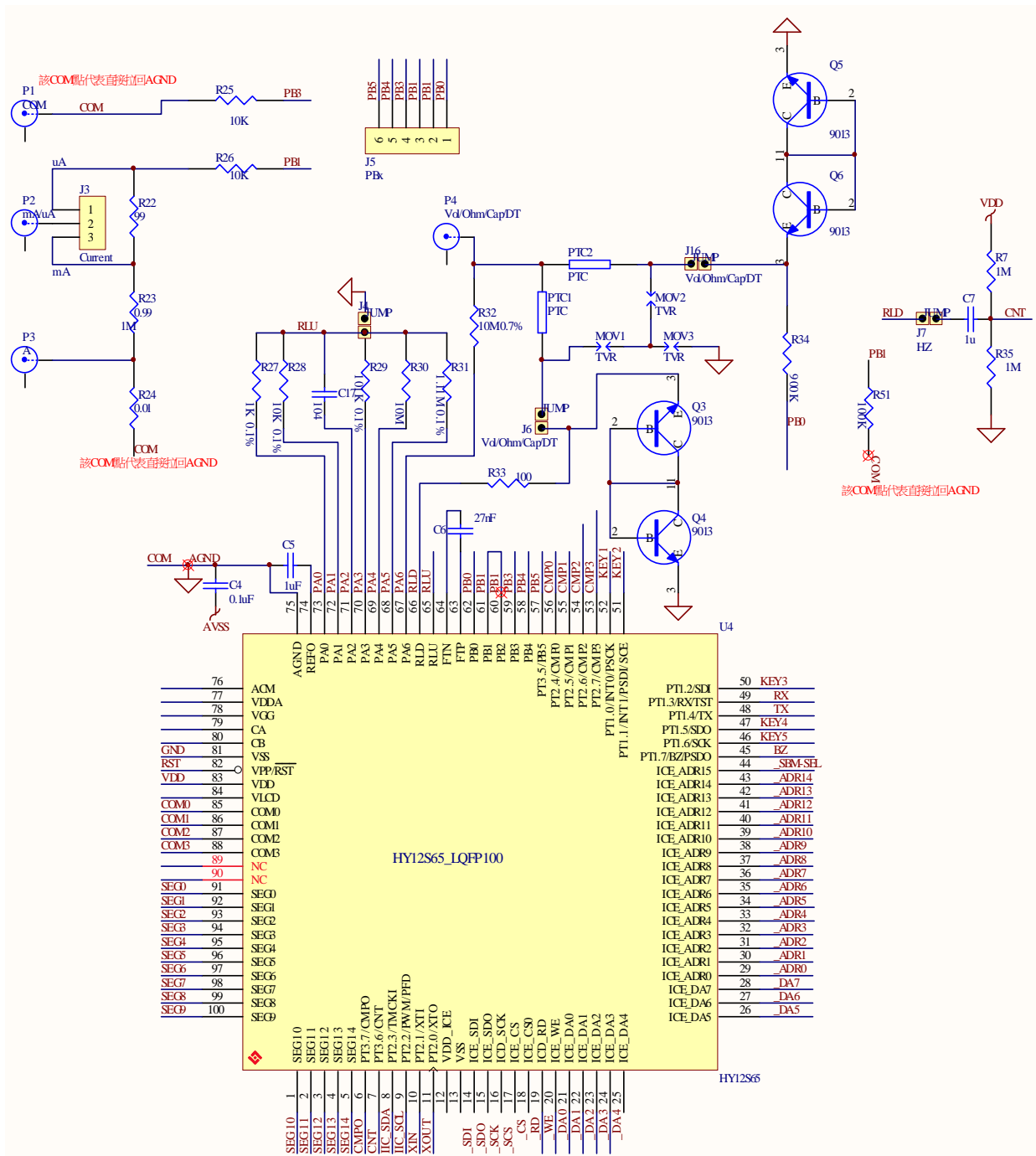

Figure 17

3.3. Circuit

Please refer to Figure 18 in below.

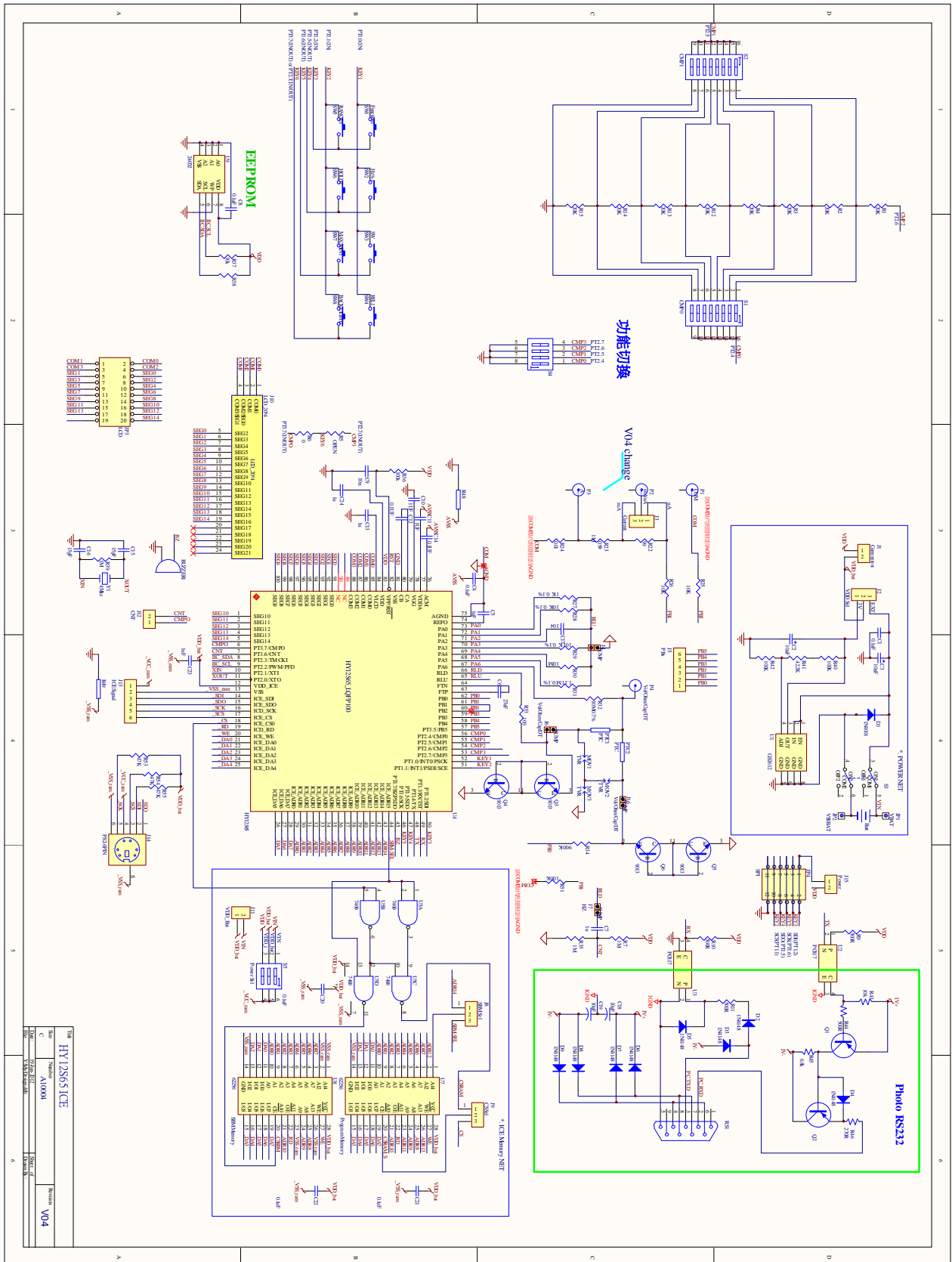

Figure 18

4. Simple Error Detection

4.1. ICE cannot connect to software



Simple error correction is described as follows when ICE cannot connect to software:

- Hardware configuration, IDE mode error detection:
 - Options =>Interface Setup =>Interface Mode defaults as USB
 - IDE Mode is emulation and Debug

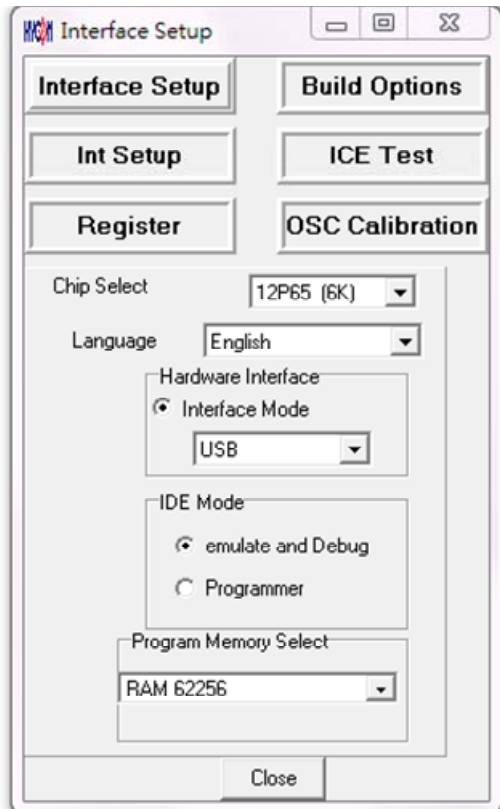

HY12S65

HY-IDE Hardware User Manual

- Power System Debug :
 - This action is to testify whether HY-IDE USB Control Board is completely connected to PC through USB port and the regulated 3V voltage output functions normally.
 - Options =>ICE Test => Click CK ALL and confirm VCC voltage is close to 3V.
 - When Control Board only connects to USB port, the voltage of VPP closes to 5V; when Adapter 9V of J4 is connected, VPP voltage will close to 6.3V.

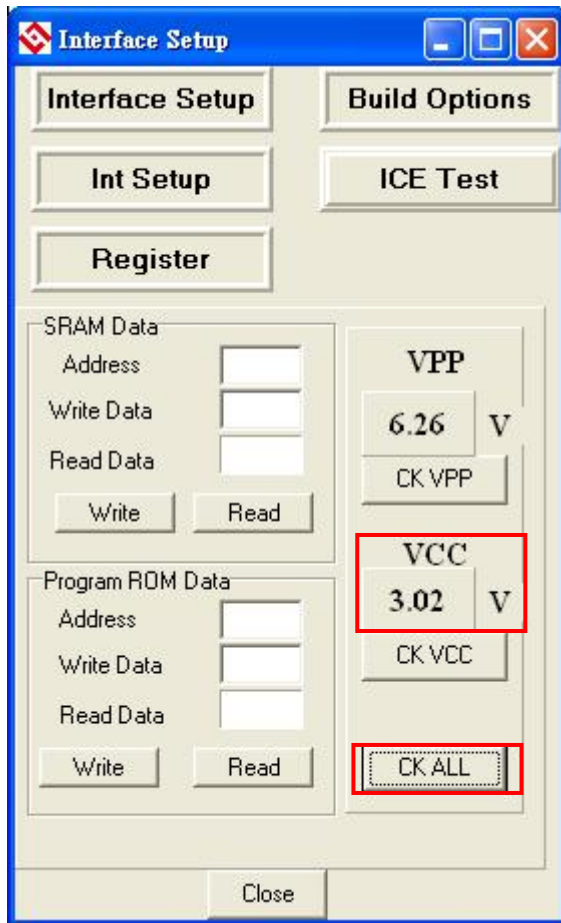

- ICE Power Debug :
 - When using USB to supply power, a few switches must be inspected to ensure ICE chip operates normally.
 - ◆ ICE Board S5, switching VIN, VDD_bat to ON



- ◆ Short ICE Board J2 PIN1-2, J1 and S3 switch turns to ON



- ◆ Using voltage meter to check whether there is a 3V voltage existed in between VDD (PIN83)-VSS (PIN81) and also a 3V voltage in between ICE_VCC (PIN12)-VSS (PIN81).
- ◆ If there is no such voltage existed, please double check the "[Power system error detection](#)" and "[ICE power error detection](#)" chapter.
- Using external power supply, please check the following switched:
 - ◆ Switching VIN, VDD_bat and VDD_i to "OFF" of the ICE Board S5.



- ◆ Connecting JP1/JP2 of the ICE Board to external voltage input, short J1, J2 and PIN1-2 (if >3V is needed, short J2 PIN2-3). Switching S3 to “ON”.



- ◆ Using voltage meter to check whether there is a 3V voltage existed in between VDD (PIN83)-VSS (PIN81) and also a 3V voltage in between ICE_VCC (PIN12)-VSS(PIN81).
- ◆ If there is no such voltage existed, please double check the "[Power system error detection](#)" and "[ICE power error detection](#)" chapter.

4.2. Program Memory Loading Error



- ICE SRAM detection:
 - Check ICE Board J8 and J9. When emulating HY12S65(8K), J1 PIN1-2 and J2 PIN1-2 must be short.



HY12S65

HY-IDE Hardware User Manual

- SRAM Data and Program ROM Data detection:
 - Options =>ICE Test =>SRAM Data
 - ◆ Input 80 in Address, AA in Write Data and then click “Write” button. Writing all data into SRAM.
 - ◆ Click “Read” button to read out all data.
 - Options =>ICE Test =>Program ROM Data
 - ◆ Input 80 in Address, 5AA5 in Write Data and then click “Write” button. Writing all data into Program ROM.
 - ◆ Click “Read” button to read out all data.

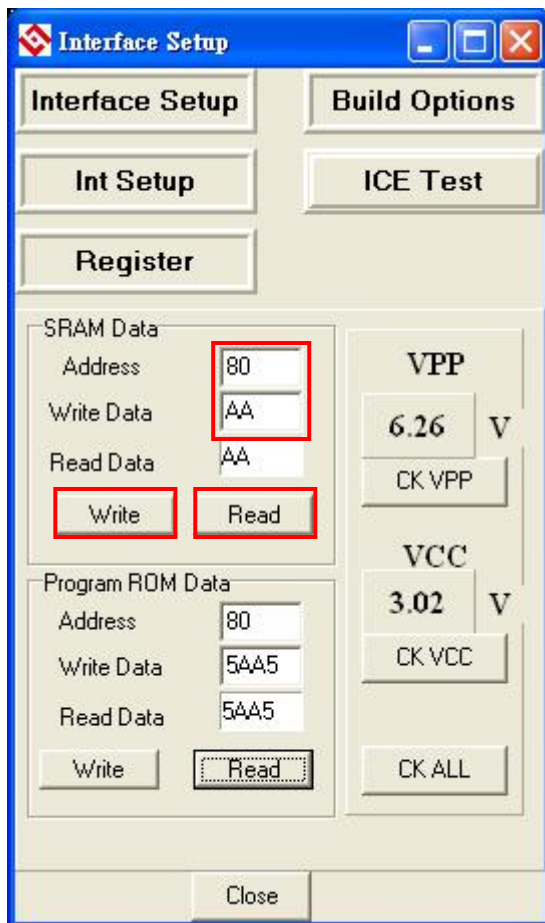

5. Revision History

Major differences are stated thereafter:

Version	Page	Revision Summary
V02	ALL	First edition