



---

# **HY16F Series ISP Bootloader Instruction Manual**

## Table of Contents

<b>1. INTRODUCTION</b> .....	<b>4</b>
<b>2. INSTRUCTIONS AND OPERATION OF HYCON BOOTLOADER TOOL</b> .....	<b>5</b>
2.1. Software Introduction .....	5
2.2. Software Installation.....	7
2.3. Uninstall .....	7
2.4. Software Operation .....	8
2.5. 4-Wire UART hardware connection (Timeout Entry) .....	11
2.6. 5-Wire UART hardware connection (CheckPin Entry).....	17
<b>3. UART BOOTLOADER FW PROTOCOL</b> .....	<b>22</b>
3.1. HY16F198B & HY16F3981 Flash Distribution.....	22
3.2. HY16F3910 Flash Distribution .....	23
3.3. UART Protocol .....	24
<b>4. ISP BOOTLOADER SPECIFICATION AND SUMMARY</b> .....	<b>30</b>
<b>5. REVISION HISTORY</b> .....	<b>31</b>

### Attention:

- 1、HYCON Technology Corp. reserves the right to change the content of this datasheet without further notice. For most up-to-date information, please constantly visit our website: <http://www.hycontek.com>.
- 2、HYCON Technology Corp. is not responsible for problems caused by figures or application circuits narrated herein whose related industrial properties belong to third parties.
- 3、Specifications of any HYCON Technology Corp. products detailed or contained herein stipulate the performance, characteristics, and functions of the specified products in the independent state. We does not guarantee of the performance, characteristics, and functions of the specified products as placed in the customer's products or equipment. Constant and sufficient verification and evaluation is highly advised.
- 4、Please note the operating conditions of input voltage, output voltage and load current and ensure the IC internal power consumption does not exceed that of package tolerance. HYCON Technology Corp. assumes no responsibility for equipment failures that resulted from using products at values that exceed, even momentarily, rated values listed in products specifications of HYCON products specified herein.
- 5、Notwithstanding this product has built-in ESD protection circuit, please do not exert excessive static electricity to protection circuit.
- 6、Products specified or contained herein cannot be employed in applications which require extremely high levels of reliability, such as device or equipment affecting the human body, health/medical equipments, security systems, or any apparatus installed in aircrafts and other vehicles.
- 7、Despite the fact that HYCON Technology Corp. endeavors to enhance product quality as well as reliability in every possible way, failure or malfunction of semiconductor products may happen. Hence, users are strongly recommended to comply with safety design including redundancy and fire-precaution equipments to prevent any accidents and fires that may follow.
- 8、Use of the information described herein for other purposes and/or reproduction or copying without the permission of HYCON Technology Corp. is strictly prohibited.

### 1. Introduction

The HY16F series allows users to divide the Flash into different blocks, and through the IDE compilation, data can be updated in fixed blocks of different Flash positions. A program that adds a Boot code function at the starting point of program operation, that is, the Bootloader program, provides the user with the function of updating the program online ISP (In-System Programming). The communication interface set by the ISP Bootloader program is UART. The Bootloader provides a platform for users to update applications online. The user can use the PC software (or the mobile APP software) and the communication tool with the UART interface to update the program of the HY16F chip online through the UART interface. This function allows the user to update any address in the Flash program area.

This article will focus on introducing the ISP Bootloader function of the HY16F series with examples. The chips that can support the ISP Bootloader function include the HY16F3981, HY16F3910, and HY16F19xB series chips. Using the HYCON Bootloader AP software provided by HYCON, in the AP software environment, the ISP online update program can be easily achieved through the UART transmission interface. Users can use the Bootloader AP software provided by HYCON for online program update, or develop their own customized Bootloader AP software for online program update.

The ISP Bootloader has already written the Bootloader FW into the Boot ROM program block, and will not occupy any Flash program space. For example: HY16F198B, HY16F3981 chip, the Flash program space size that can be updated through ISP Bootloader is 64KB. The HY16F3910 chip, the Flash program space size that can be updated is 128KB. The default function of ISP Bootloader is not enabled (Disable), the user must first enable (Enable) through the ISP Resource Setting of HY16F Writer. After power on or reset, it will determine whether to enter the ISP Bootloader mode through the UART transmission interface.

## 2. Instructions and operation of HYCON Bootloader tool

### 2.1. Software Introduction

PC software: HYCON Bootloader, the operation screen is as shown in Figure 1 and Figure 2. HYCON Bootloader AP software is suitable for HY16F series chips and HY17M26. This article will focus on the instructions for using the Bootloader tool for the three chips HY16F198B/HY16F3981/HY16F3910.

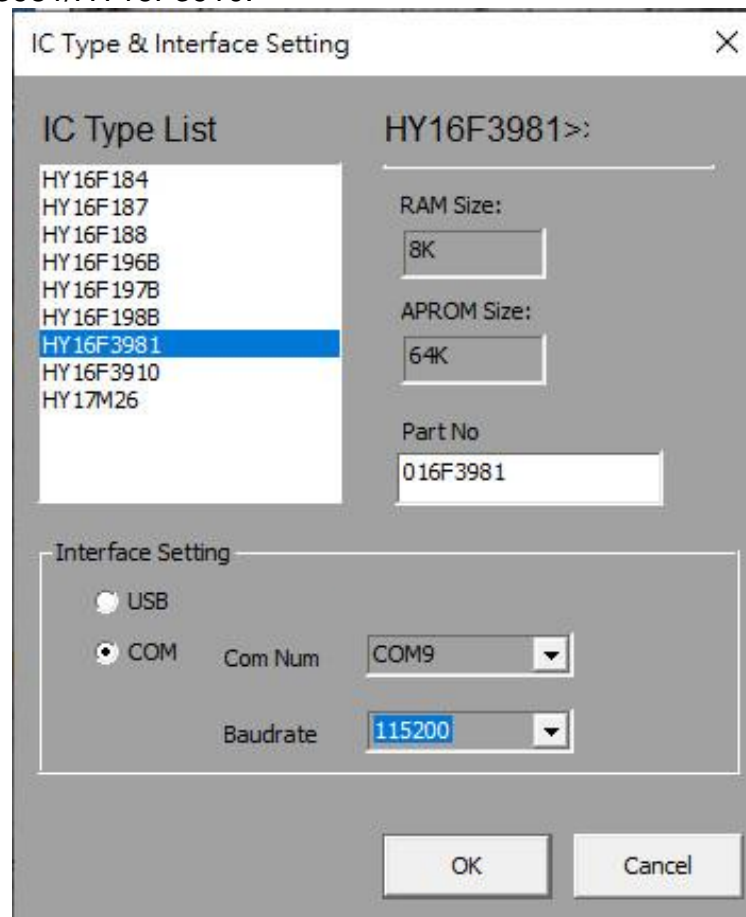

Figure 1. IC selection screen

# HY16F Series ISP Bootloader Instruction Manual

After selecting the IC type, you can jump into the HYCON Bootloader software operation screen.

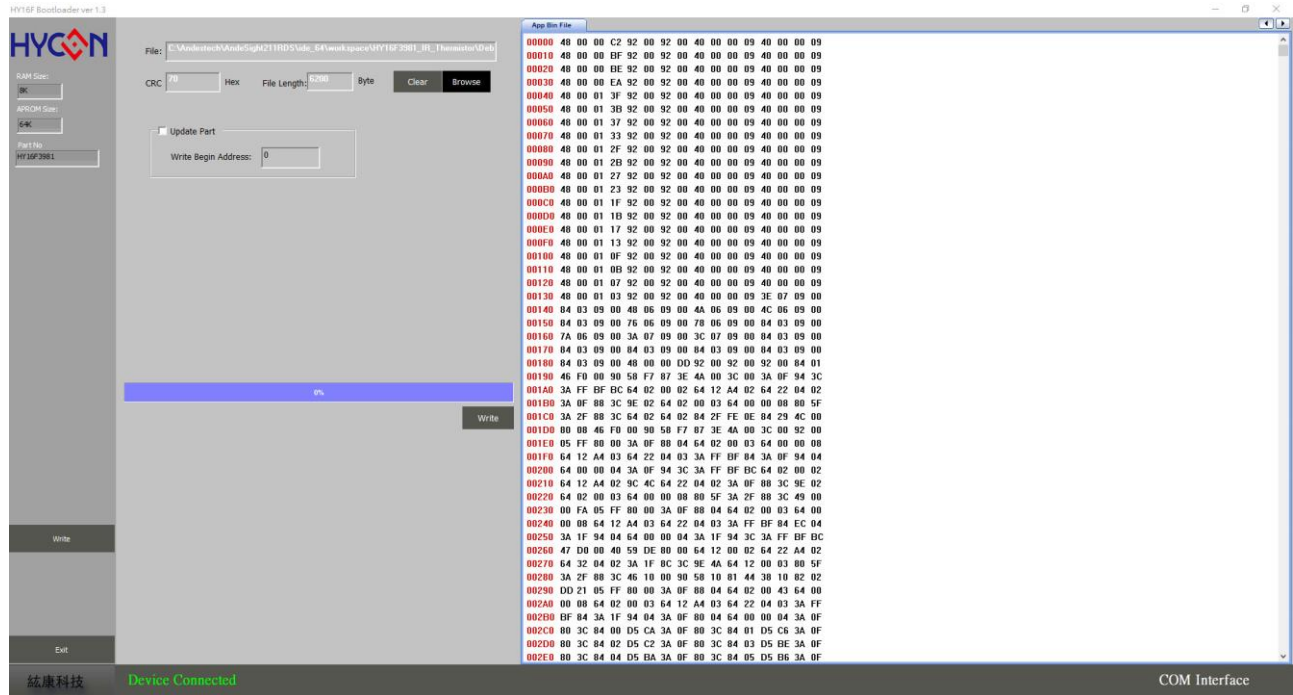

Figure 2. HYCON Bootloader software operation screen

### 2.2. Software Installation

The following will introduce the HYCON Bootloader software installation process. The minimum system configuration required to run the HYCON Bootloader application software:

- PC Hardware Requirement :
  - PC compatible with ( PENTIUM® ) system
  - 256MB Memory ( recommend 512MB )
  - 500MB Hard disk
- Operating System Support:
  - Windows XP (32 bit), Windows 7 (32 bit/64 bit), Windows 8 (32 bit/64 bit), Windows 10 (64 bit)
- Apply the following interface:
  - USB Port
- Software Version Support
  - HY16F Bootloader V1.3 above
- Support Chip Product Model :
  - HY16F product: HY16F184, HY16F187, HY16F188, HY16F196B, HY16F197B, HY16F198B, HY16F3981, HY16F3910
  - HY17M product: HY17M26
- Program Version Compatibility:
  - Through the HY16F IDE software version compiled file (bin file), can be burned by HY16F Bootloader V1.3

Unzip the HYCON Bootloader software and execute the Setup.exe.

Execute the Setup.exe executable file to start the installation, and follow the instructions on the screen to perform the installation steps step by step to complete the installation.

Note : For some Windows operating systems, installing the software on your computer requires administrator access.

### 2.3. Uninstall

Please go to the control panel(Windows) "Add or Remove Programs" to find "HYCON Bootloader" to select the removal program.

### 2.4. Software Operation

This chapter uses the type selection HY16F3981 for software operation instructions.

I ) It is necessary to confirm that the ISP Bootloader function of the current IC is enabled (Enable). To enable (Enable) Bootloader function, it can be set through HY16F Writer. The following picture is the setting screen of using HY16F Writer as Bootloader (Enable) (for detailed operation instructions, please refer to the HY16F Writer Kit Instruction manual). Click on the extension window to the right of ISP Resource Setting, and the ISP Resource Setting menu will pop up. From top to bottom, check Enable ISP first, and then choose one of Timeout Entry or CheckPin Entry mode for Bootloader transmission. The picture below selects 5-wire UART (CheckPin Entry), ISP Uart Port=PT2.0&PT2.1, ISP Check pin=PT2.2, the value of ISP Resource Setting will be 01030355. If you choose different modes and different transmission pin settings, you will get different codes. The ISP Resource Setting status of the chip is FFFFFFFF, which means that the Bootloader status is Disabled.

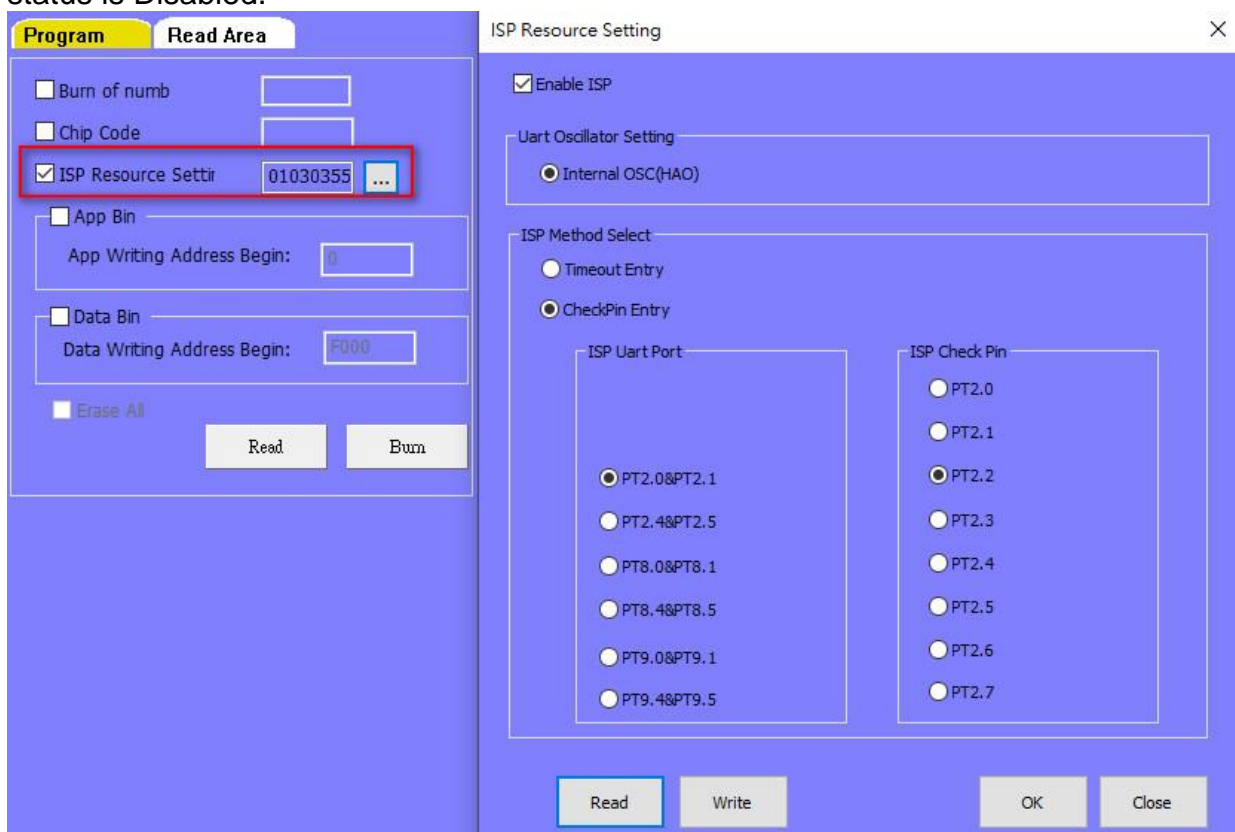

Figure 3 HY16F Writer operation screen (ISP Resource Setting)

II ) After setting up the hardware environment, choose to connect 4-wire UART (Timeout Entry) or 5-wire UART (CheckPin Entry) according to the settings of ISP Resource Setting. Power on the IC, if the chip has been powered on in advance, use the RESET function to reset the IC, and then execute the HYCON Bootloader AP software, first an IC selection dialog box pops up, select the corresponding type, select the COM communication interface, and select the serial port number and communication serial transmission rate, click OK.



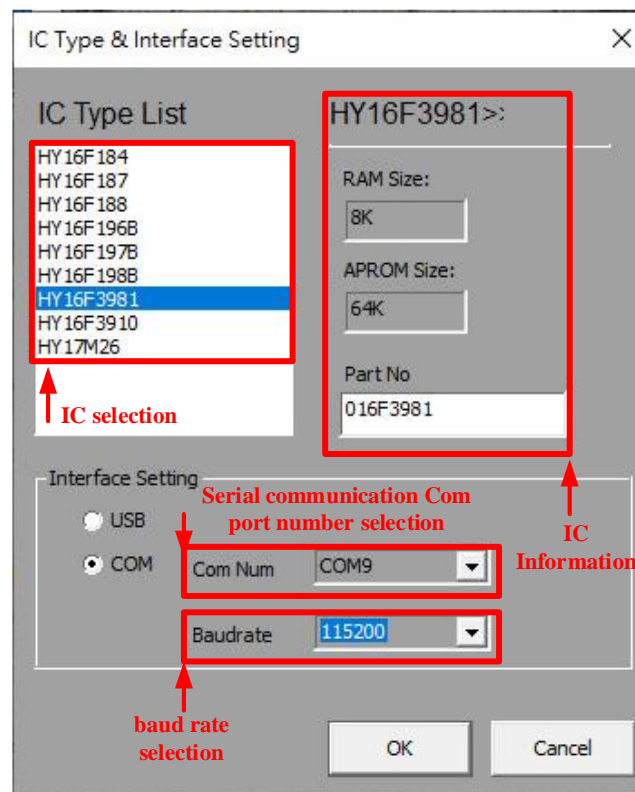

Figure 4. IC selection dialog

III) Select the IC and UART interface communication settings (select COM), in the process of entering the programming interface, the software will first perform automatic serial transmission rate verification with the target IC, auto baud rate verification. If the automatic serial transmission rate calibration is successful and the IC communication is normal, it will automatically connect, and it will prompt 'Device Connected' in the lower left corner. Otherwise, it will prompt 'Device Disconnected'. If the automatic serial transfer rate calibration fails, an information window will pop up to prompt 'Auto Detect Baudrate Fail', you need to reset the IC.

IV) After entering the software, the current interface is the interface for programming the IC, and you can see the corresponding information of the selected IC in the upper left corner.

V) Click 'Browse' to select the bin file to be downloaded. After the file is loaded successfully, you will see the path and file size of the file.

Note: The file to be opened cannot be called by other programs at the same time; if the loaded bin file is larger than the user's available program space, an error message box will be displayed 'File Size Must Not exceed 64K !'. HY16F198B & HY16F3981 can only load bin files with a size of 64KB at most, only HY16F3910 can support bin files with a size of 128KB.

VI) Modify the burning start address, if not, the default is to start burning from the APP Flash starting position 0x90000

VII) Click the 'write' button next to the progress bar to start the download; during the writing process, the progress bar will display 'updateing+progress', after the writing is completed, perform calibration, and the calibration process will display 'Verifying+progress', if the programming is wrong, the progress bar will display error messages such as 'Communication Error' or 'Verify Error'. Press the 'Exit' button in the lower left corner to exit the software.

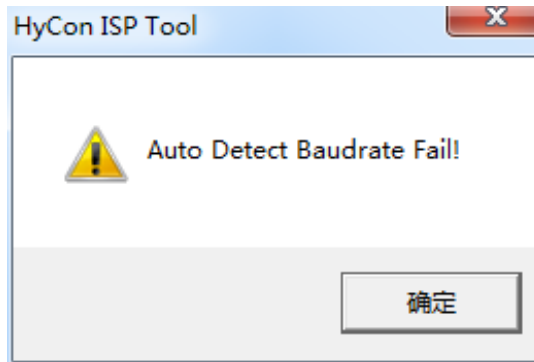

Figure 5. Auto serial transfer rate failed

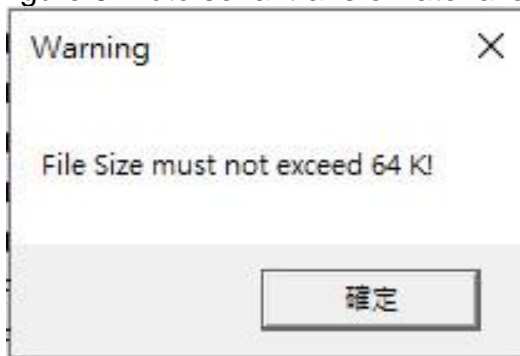

Figure 6. The loading file is larger than the user's free space error prompt

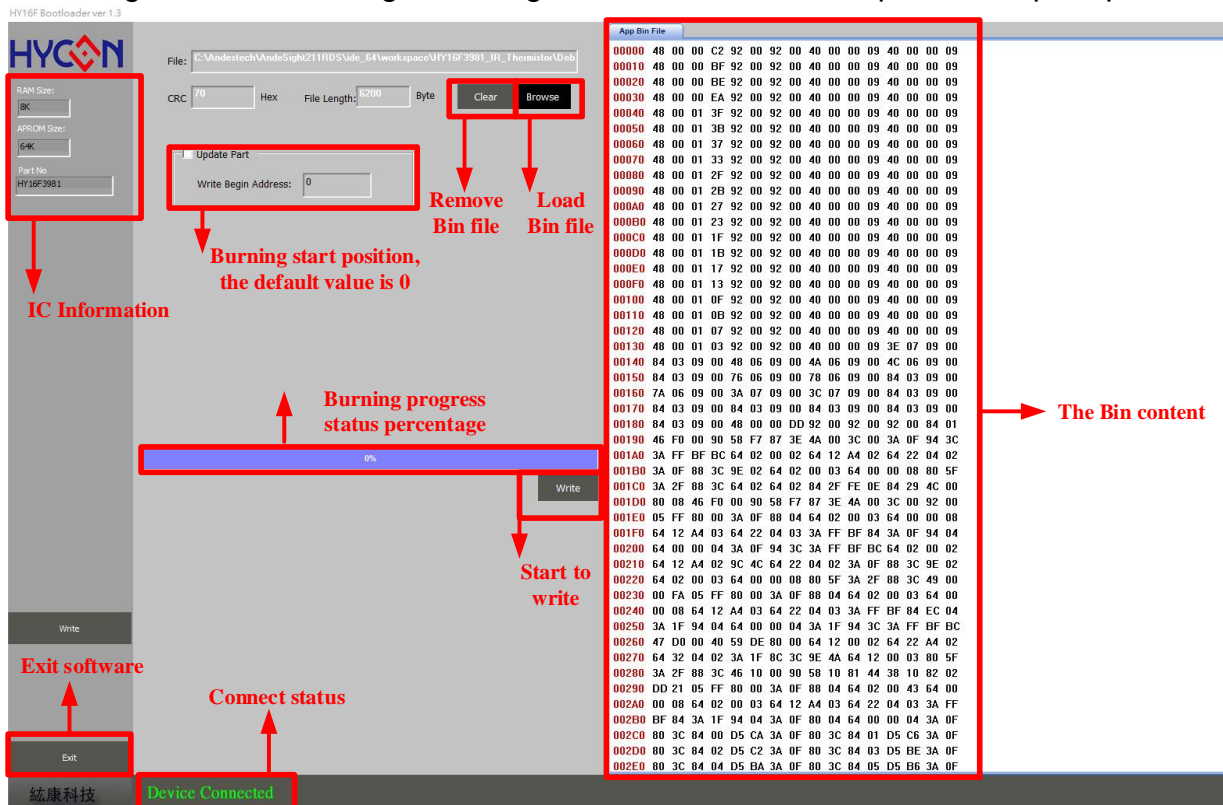

Figure 7. Online program update function software interface

## 2.5. 4-Wire UART hardware connection (Timeout Entry)

HY16F3910, HY16F3981, HY16F19xB series all support 4-wire (Timeout Entry) and 5-wire (CheckPin Entry) UART transmission ISP Bootloader function. Users can plan and set the UART communication pins according to the actual product and hardware design planning requirements. The UART communication pins can be set through the HY16F Writer. Here, the 4-wire (Timeout Entry) transmission mode is introduced first. When the Bootloader function has been enabled (Enable), the external USB to UART communication control board controls the VDD power pin of the chip through RTS#, so that the chip can be powered off and powered on again, and the chip will judge whether the power-on has been received within the time. Go to the UART timeout command to decide whether to continue in Bootloader mode. If the UART timeout command is not received within the time limit, it will jump out of Bootloader mode and return to Normal mode, which normally works normally.

### UART Timeout Entry :

About 100ms after the chip is powered on, the Host starts to send UART commands to the Slave, and completes the following UART auto-baud rate and handshake steps within 300ms:

1. The Host side sends 0x55 to enter the Auto-Baud Rate process.

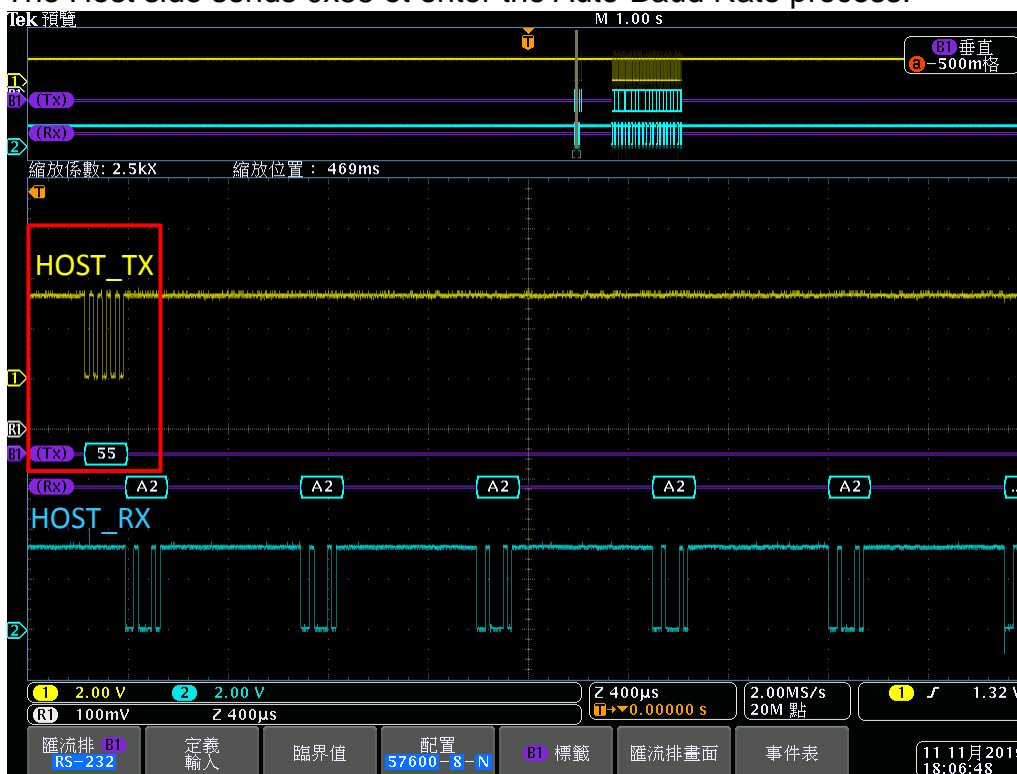

- The Slave performs Auto-Baud Rate after receiving it. If it is correct, the Slave will continue to send ACK\_SLAVE (0xA2) for about 3~5 seconds.

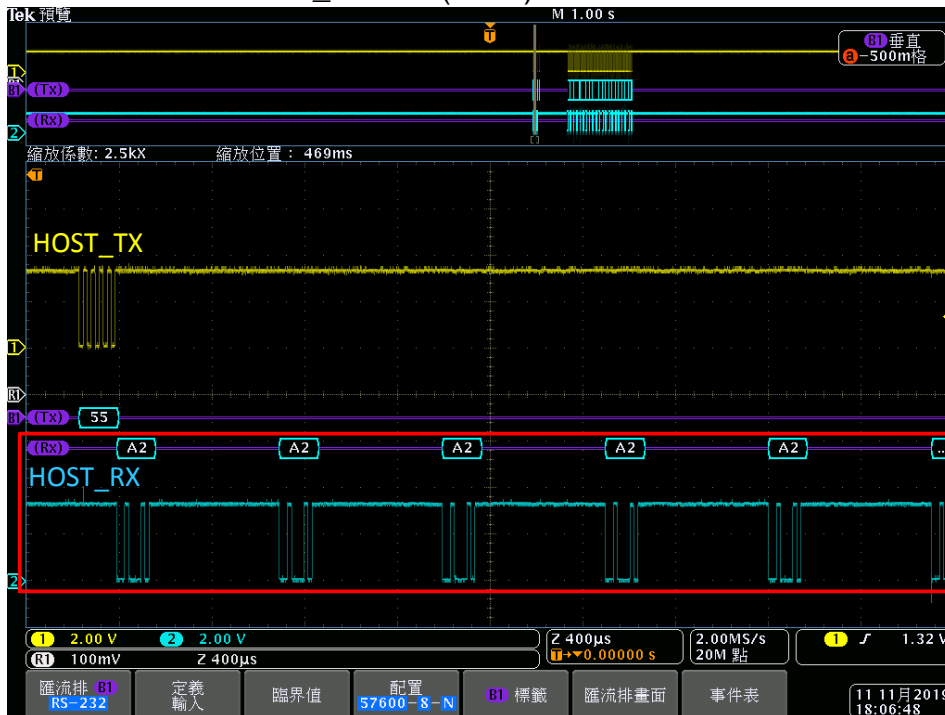

- When the Slave sends ACK\_SLAVE (0xA2), the Host needs to send ACK\_MASTER (0xA1), then the Slave replies with ACK\_HANDSHAKE (0xA3) to complete the Host-Slave UART Handshake.

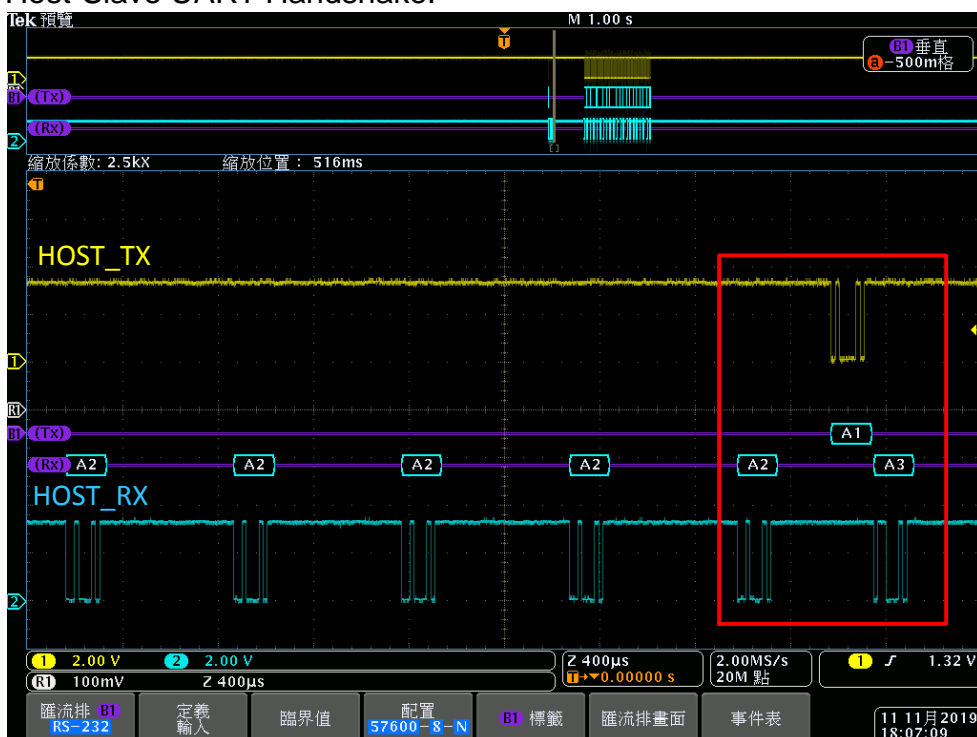

If the above 3 steps are completed within 300ms, the chip will continue to be in Bootloader mode, and the following ISP command can be performed to execute the Bootloader FW program update.

# HY16F Series ISP Bootloader Instruction Manual

- If the Host side receives not ACK\_SLAVE(0xA2), or does not send ACK\_MASTER(0xA1) during ACK\_SLAVE(0xA2), the Slave returns to perform Auto-Baud Rate Handshake again and continues to wait for the Host side to send 0x55.

The default 4-wire UART communication pins are PT2.0(TX)/PT2.1(RX)/VDD3V/VSS, a total of 4 pins. If the RTS pin of the common USB to UART Bridge is used to control the VDD power supply of the chip, because the driving capability of the RTS IO is insufficient, two external transistors need to be connected to achieve the 4-wire UART Bootloader program update (connection method 1). If users can use HYCON's customized Bootloader Bridge PCB: HY10001-CM01 HY-Bridge Board. Only need pin to pin connection to complete the 4-wire UART Bootloader program update (connection method 2). The system connection diagram is as follows.

### (Timeout Entry) 4-wire UART transmission, connection method 1: use USB to UART communication control board + 2 external BJT

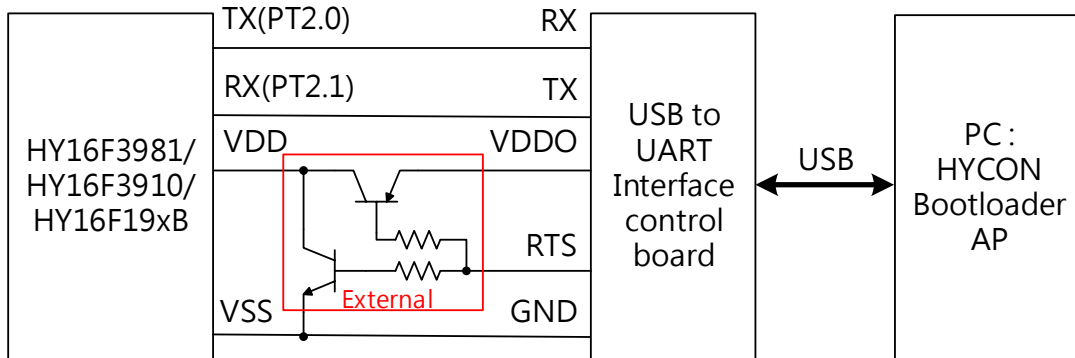

### (Timeout Entry) 4-wire UART transmission, connection method 2: using HY10001-CM01, HY-Bridge Board

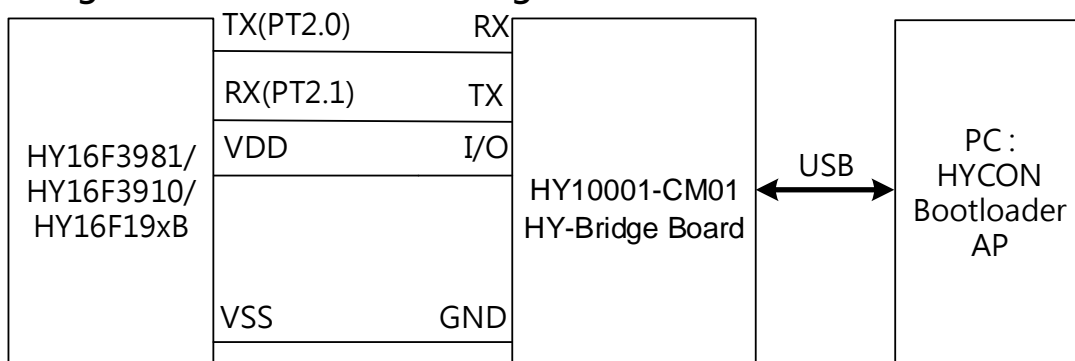

Figure 8. System connection architecture diagram

# HY16F Series ISP Bootloader Instruction Manual

HY10001-CM01  
HY-Bridge Board

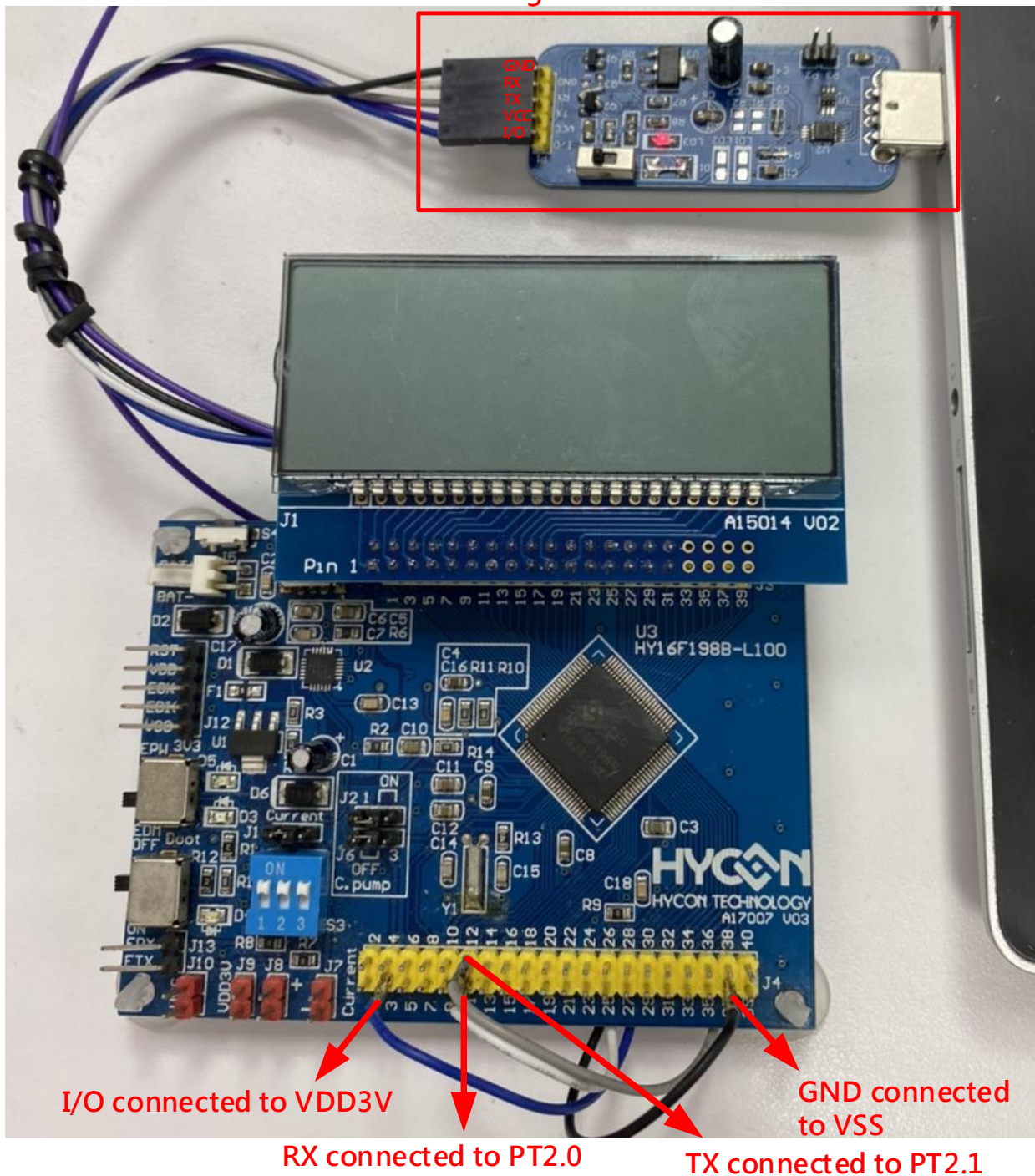

Figure 9. HY16F198B hardware connection (4-wire UART)

# HY16F Series ISP Bootloader Instruction Manual

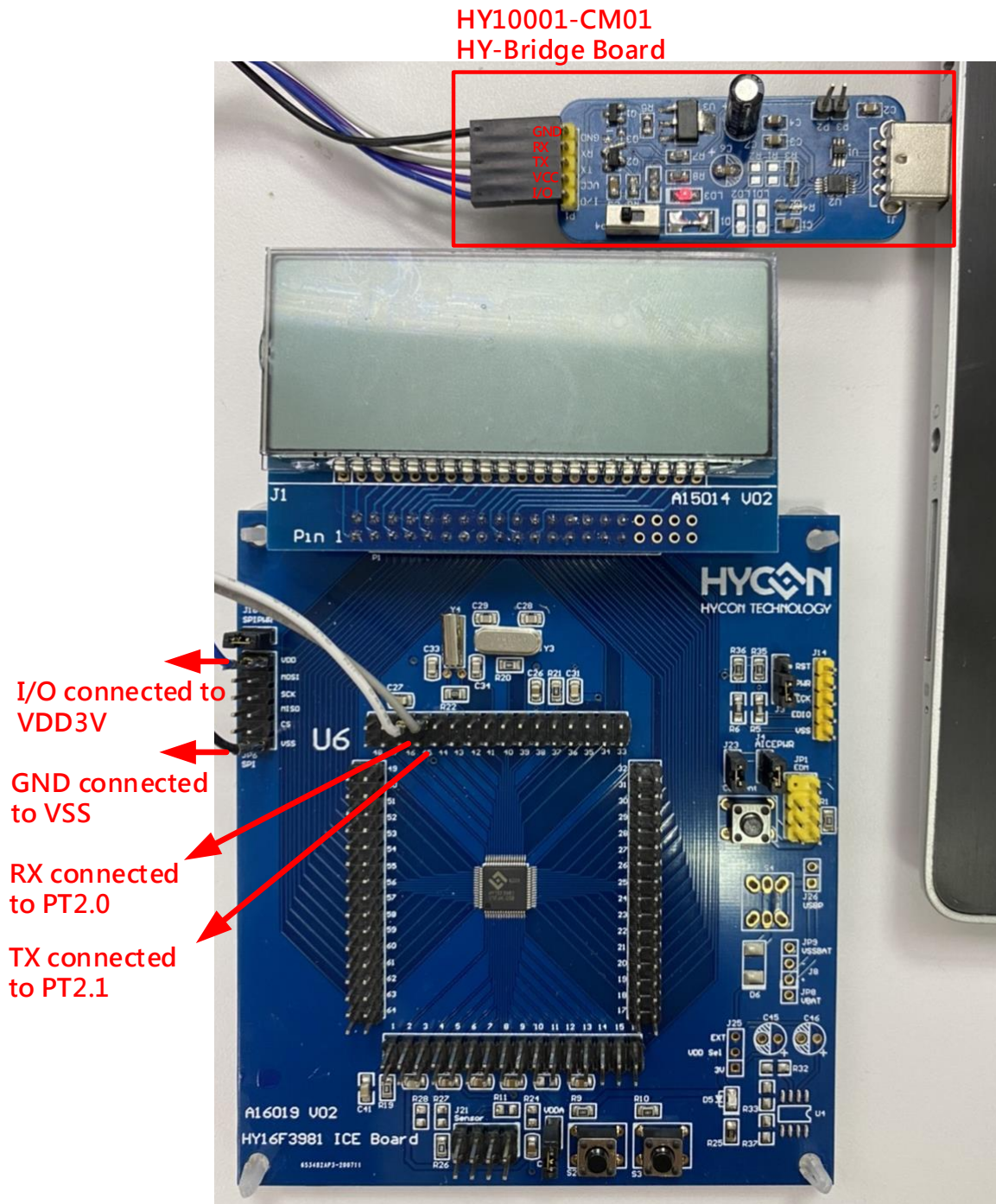

Figure 10. HY16F3981 hardware connection (4-wire UART)

# HY16F Series ISP Bootloader Instruction Manual

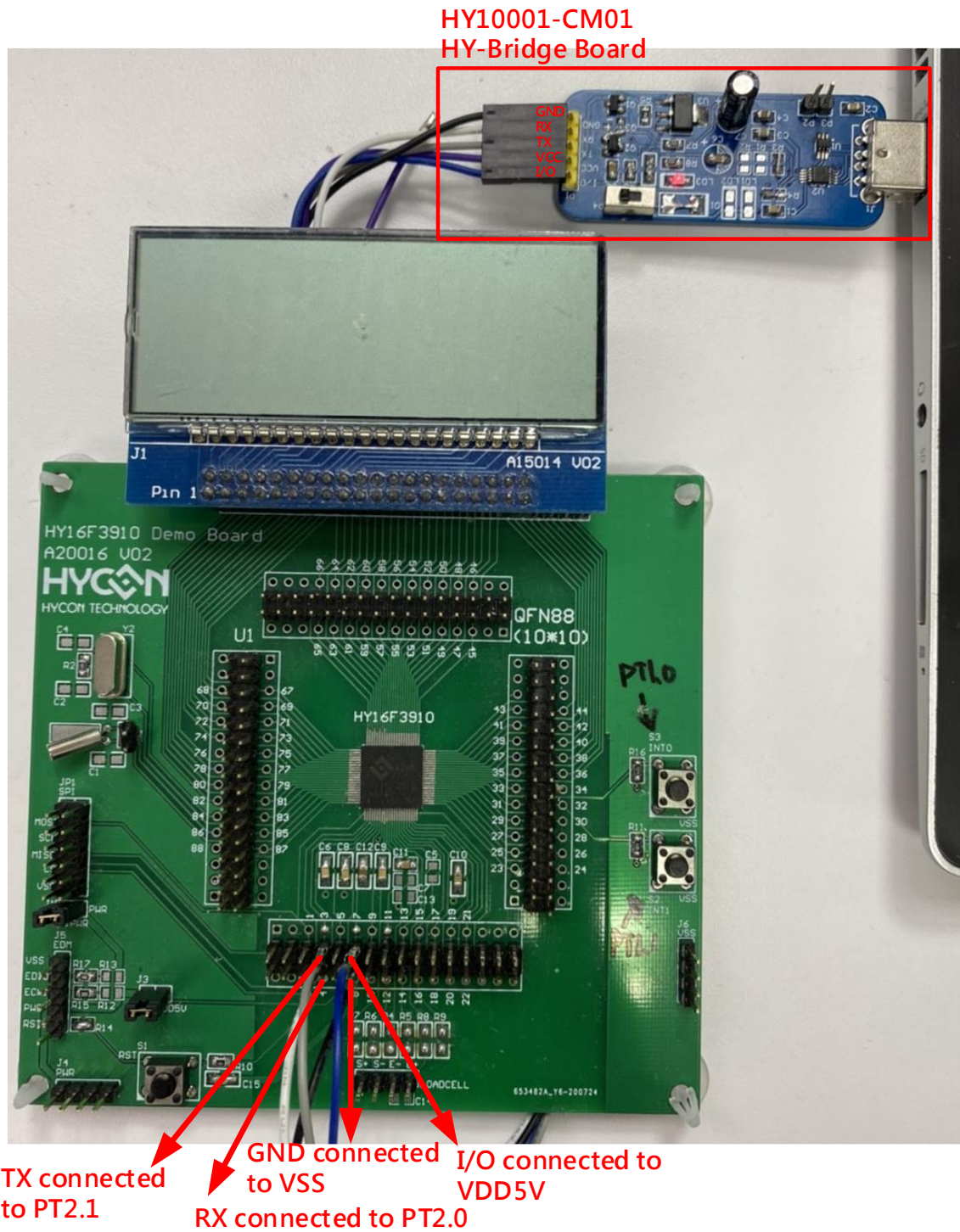

Figure 11. HY16F3910 hardware connection (4-wire UART)



### 2.6. 5-Wire UART hardware connection (CheckPin Entry)

The user can choose and set the UART communication pin according to the actual product and hardware design plan. The UART communication pin can be set to 5-wire UART (CheckPin Entry) transmission mode through the HY16F Writer. In this example: Set the 5-wire UART Bootloader communication pins as PT2.0(TX), PT2.1(RX), PT2.2(ISP\_EN). After the bootloader function of the chip has been turned on, every power-off & power-on behavior, the ISP\_EN pin determines whether the power-on is in the High or Low state. If it is in the Low state, the chip will continue to remain in the Bootloader mode after power-on. So if you want to enter the Bootloader mode normally, the external circuit should have the External pull low ISP\_EN pin before the chip is powered on. Supplementary Note: If you do not enter Bootloader mode after power-on, you only need to keep the ISP\_EN pin in the open state (or external pull-up High) state.

#### UART CheckPin Entry :

When the chip is powered on for about 100ms, the chip determines whether the status of the ISP\_EN pin is Low. If it is Low, it means that the chip continues to remain in Bootloader mode. The Host side starts to send the UART command to the Slave, and completes the following UART auto-baud rate and handshake steps:

1. The Host side sends 0x55 to enter the Auto-Baud Rate process.
2. The Slave performs Auto-Baud Rate after receiving it. If it is correct, the Slave will continue to send ACK\_SLAVE (0xA2) for about 3~5 seconds.
3. When the Slave sends ACK\_SLAVE (0xA2), the Host needs to send ACK\_MASTER (0xA1), then the Slave replies with ACK\_HANDSHAKE (0xA3) to complete the Host-Slave UART Handshake.

After completing the above 3 steps, the chip will continue to be in Bootloader mode, and the subsequent Bootloader FW program update can be performed.

Note: During this period, if the state of the ISP\_EN pin is High, the chip will jump out of the Bootloader mode and return to the normal mode of normal operation.

4. If the Host receives something other than ACK\_SLAVE(0xA2), or does not send ACK\_MASTER(0xA1) during ACK\_SLAVE(0xA2), the Slave returns to perform Auto-Baud Rate Handshake again and continues to wait for the Host to send 0x55.

(CheckPin Entry) 5-wire UART transmission, connection method 1:  
use USB to UART communication control board

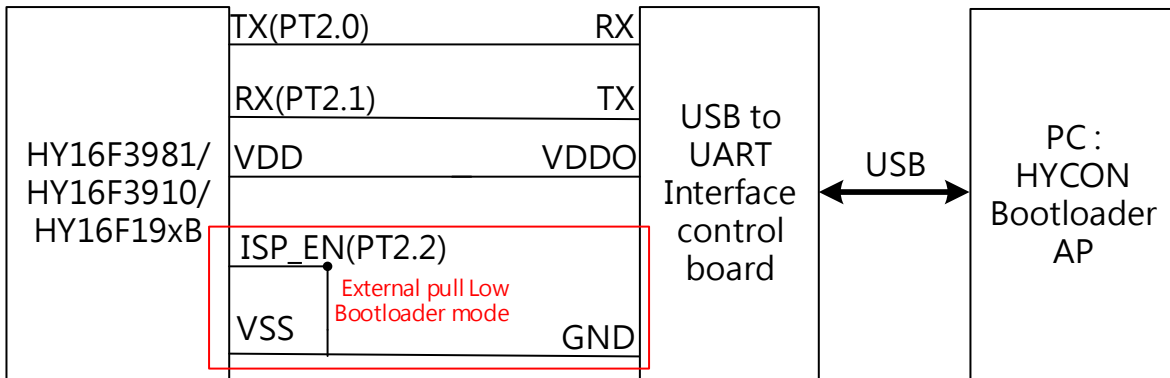

(CheckPin Entry) 5-wire UART transmission, connection method 2:  
Use HY10001-CM01, HY-Bridge Board

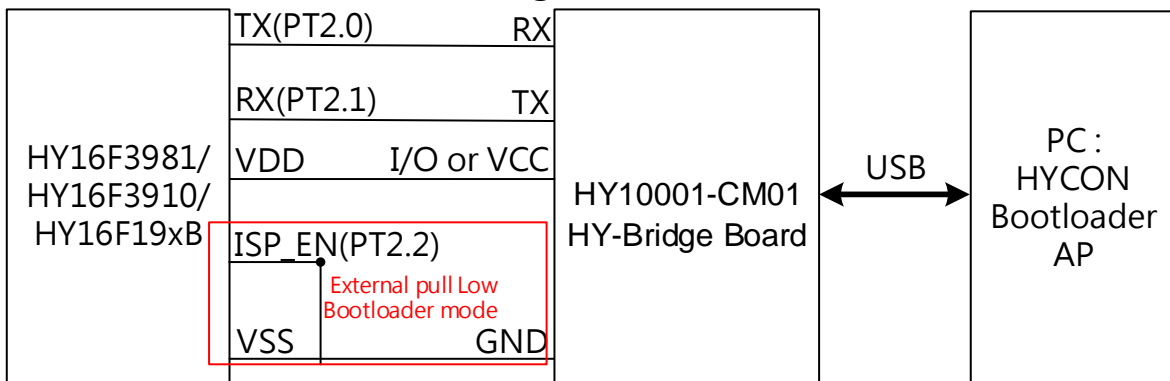
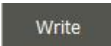

Figure 12. System connection architecture diagram

Note:

Use (CheckPin Entry) 5-wire UART, if the operation starts from IC selection (screen 1) to the HYCON Bootloader software operation screen (screen 2) before the AP presses the Write button . It is necessary to perform a Reset action on the chip externally, and then press the Write button to update the program to update the program normally. If the user is using HY-Bridge Board to do (CheckPin Entry) 5-wire UART, he can use the I/O pin of HY-Bridge Board to connect the VDD of the chip, without the need to reset the chip, just press Press the Write button to update the Bootloader program. Because when the Write button is pressed, the I/O pins can be used to perform power-off & power-on actions on the VDD of the chip, which is equivalent to a Reset action.

# HY16F Series ISP Bootloader Instruction Manual

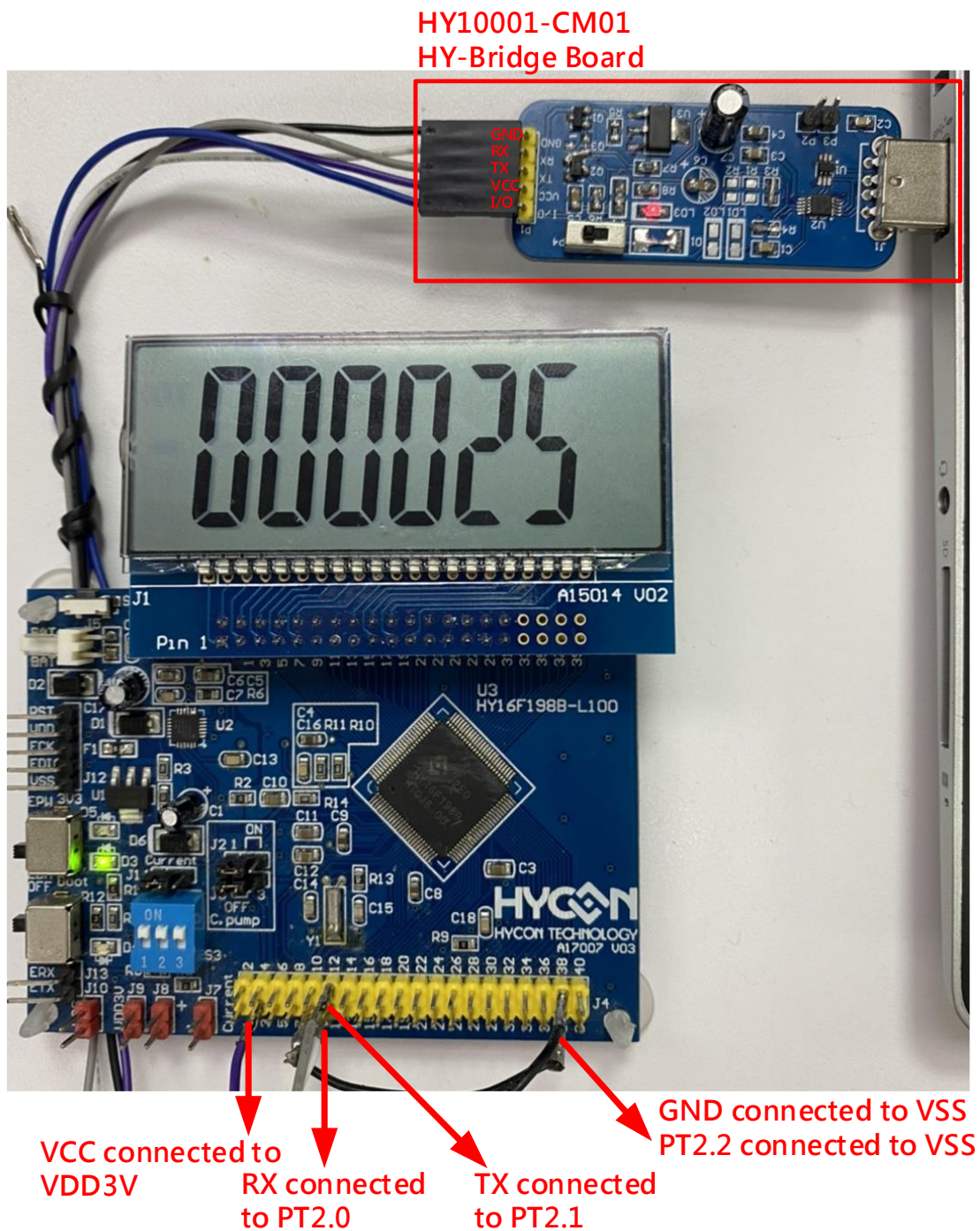

Figure 13. HY16F198B hardware connection (5-wire UART)

# HY16F Series ISP Bootloader Instruction Manual

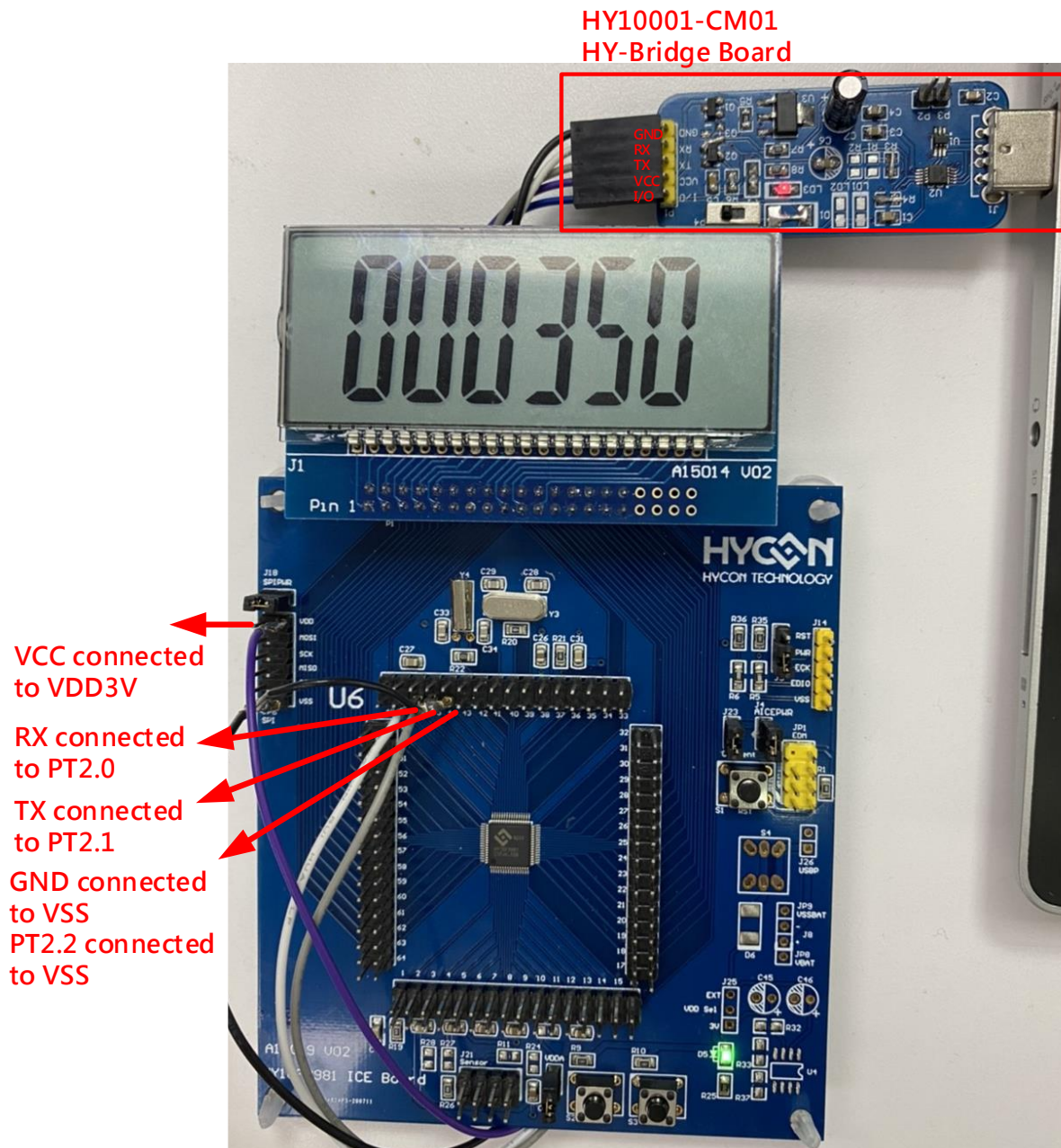

Figure 14. HY16F3981 hardware connection (5-wire UART)

# HY16F Series ISP Bootloader Instruction Manual

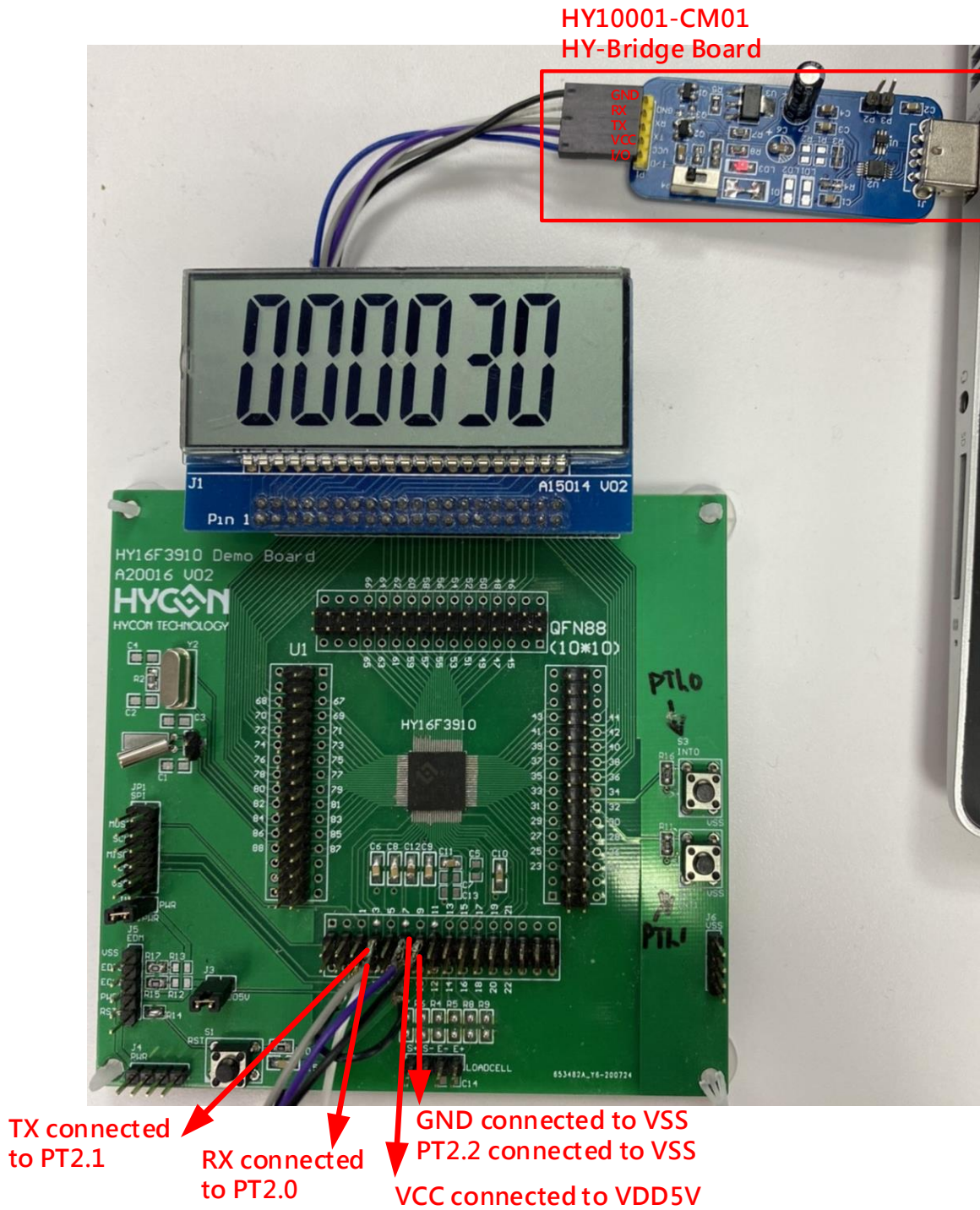

Figure 15. HY16F3910 hardware connection (5-wire UART)

### 3. UART Bootloader FW Protocol

#### 3.1. HY16F198B & HY16F3981 Flash Distribution

Flash function block description :

**0x80000 to 0x81FFF Boot ROM (8K Byte)** : Support (Timeout Entry)4-WIRE and (CheckPin Entry) 5-WIRE UART interface ROM ISP Bootloader function. The default setting is DISABLE status. User can use HY16F Writer (Or IC programming service) to ENABLE ROM ISP Bootloader function.

**0x90000 to 0x9FFFF** : Main Program Flash ROM (64K Byte).

**0x90000 Start Up Code** : Before the main, contains the interrupt handler stack initialization action. Writtern in assembly is completed.

**0x9F000 Data Flash** : The user saves the valid parameter space, the default starting position is 0x9F000, the user can change the starting position according to the actual product design requirements.

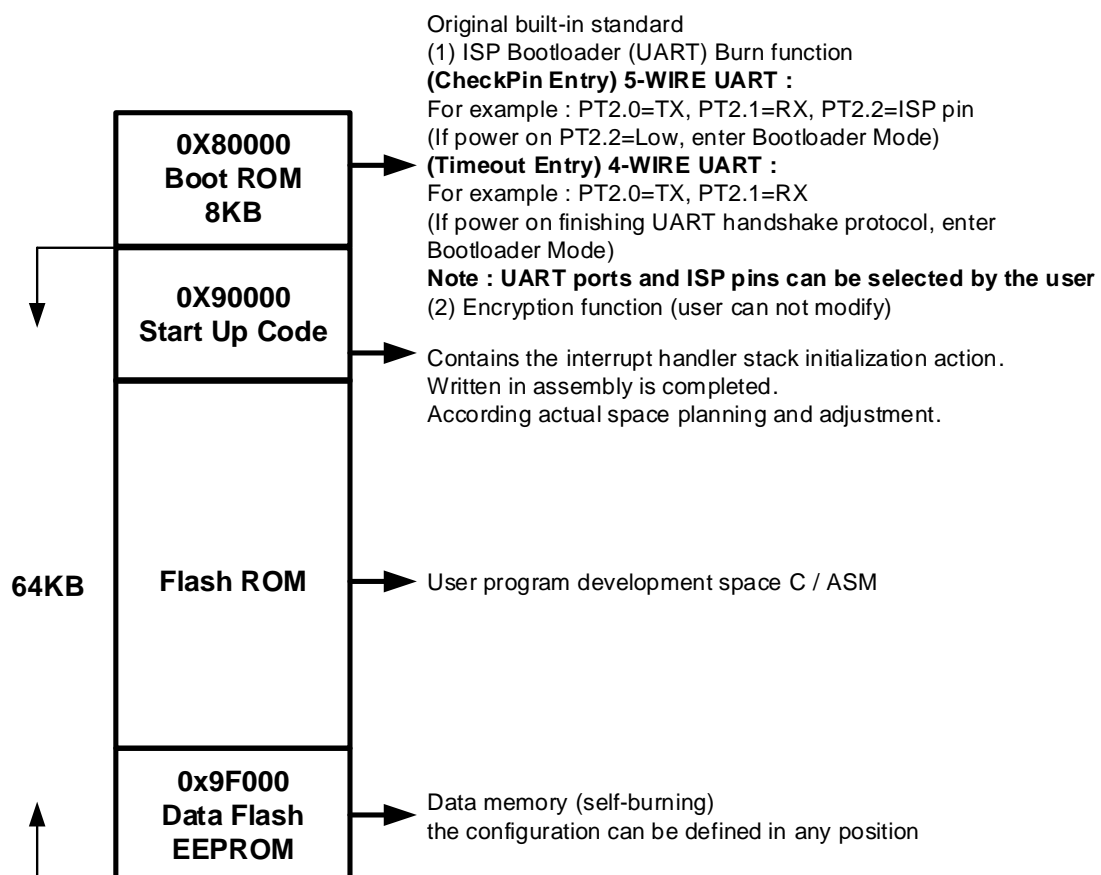

HY16F198B & HY16F3981 Flash function block description

### 3.2. HY16F3910 Flash Distribution

Flash function block description :

**0x80000 to 0x81FFF Boot ROM (8K Byte)** : Support (Timeout Entry)4-WIRE and (CheckPin Entry) 5-WIRE UART interface ROM ISP Bootloader function. The default setting is DISABLE status. User can use HY16F Writer (Or IC programming service) to ENABLE ROM ISP Bootloader function.

**0x90000 to 0xAFFFF** : Main Program Flash ROM (128K Byte).

**0x90000 Start Up Code** : Before the main, contains the interrupt handler stack initialization action. Writtern in assembly is completed.

**0xAFC00 Data Flash** : The user saves the valid parameter space, the default starting position is 0xAFC00, the user can change the starting position according to the actual product design requirements.

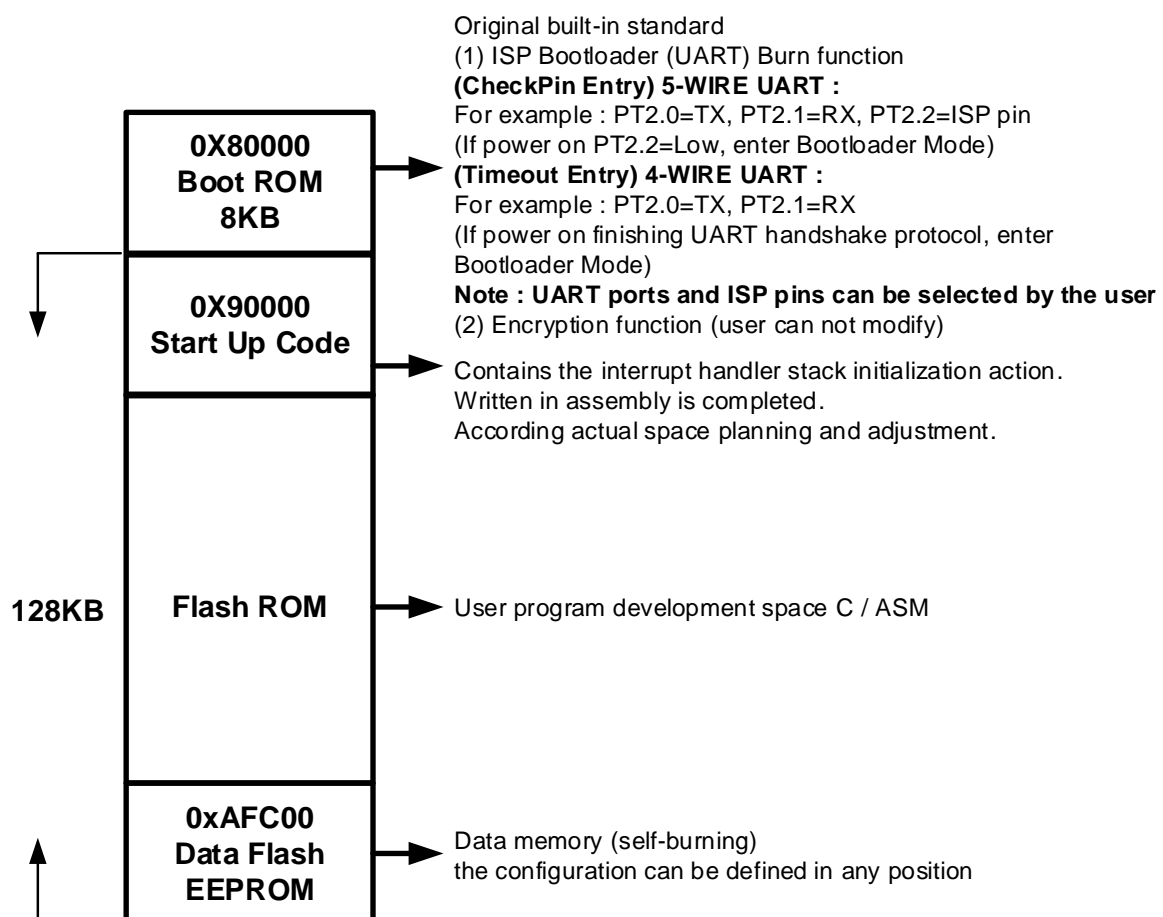

HY16F3910 Flash Flash function block description

# HY16F Series

## ISP Bootloader Instruction Manual

### 3.3. UART Protocol

Users can refer to this chapter to develop a customized version of Bootloader AP software.

UART auto-baud rate and handshake handshake protocol, the purpose is to make the working frequency of the UART at both ends of the Host and Slave consistent, and confirm that the UART at both ends of the Host and Slave can communicate normally.

Description: The 4-wire UART judges whether it is in Bootloader mode through UART timeout command, and the 5-wire UART judges whether it continues in Bootloader mode through ISP\_EN pin. When the chip confirms that it has been in Bootloader mode and also completes the UART auto-baud rate and handshake, the subsequent ISP command transmission control can be performed. The command transmission of ISP command refers to the three major projects of ISP Command Package, ISP Command (Host to Slave) and ISP Command (Slave to Host). According to these ISP Commands, the chip can execute Bootloader FW program update.

#### 3.3.1. ISP Command Package-(For HY16F198B & HY16F3981)

Sync Char1	Sync Char2	Command Code	Data Length	Payload	Check Sum
0x55	0xAA	1 Byte	1 Byte	Data number according to Length Field	1 Byte

←-----Checksum calculation range-----→→

#### 3.3.2. ISP Command Package-(For HY16F3910)

Sync Char1	Sync Char2	Command Code	Data Length	Payload	Check Sum
0x55	0xAA	1 Byte	1 Byte	Data number according to Length Field	1 Byte

←←-----Checksum calculation range-----→→



# HY16F Series

## ISP Bootloader Instruction Manual

### 3.3.3. ISP Command (Host to Slave)-(For HY16F198B & HY16F3981)

ISP Command	Command Code	Data Length	Payload
SECTOR_ERASE	0x92	0x2	<AddrH><AddrL>
PAGE_ERASE	0x93	0x2	<AddrH><AddrL>
WORDS_WRITE	0x94	0x2+N; N<= 0x20	<AddrH><AddrL> <Word0><Word 1>.....<WordN-2><WordN-1>
PAGE_WRITE	0x95	0x82	<AddrH><AddrL> <Word0><Word 1>.....<Word30><Word31>
WORDS_WRITE_ONLY	0x96	0x2+N; N<= 0x20	<AddrH><AddrL> <Word0><Word 1>.....<WordN-2><WordN-1>
PAGE_WRITE_ONLY	0x97	0x82	<AddrH><AddrL> <Word0><Word 1>.....<Word30><Word31>
ALL_ERASE	0x98	0x4	<AddrH><AddrL><Data_Length_H> <Data_Length_L><ExpectCS>
PAGES_READ_CHECKSUM	0x81	0x4	<AddrH><AddrL><NumPage> <ExpectCS>
SECTORS_READ_BLANK	0x82	0x3	<AddrH><AddrL><NumSector>

Note:

<Word>=<Byte0MSB><Byte1><Byte2><Byte3LSB>

1 word=4bytes

### 3.3.4. ISP Command (Host to Slave)-(For HY16F3910)

ISP Command	Command Code	Data Length	Payload
CMD_MASS_ERASE	0x11	0x00	N/A
CMD_SECTOR_ERASE	0x12	0x04	<Addr>
CMD_WORDS_WRITE	0x93 Len=0x400	0x04 0x04+ Len	<Addr> <Word0><Word1>.....<Word254><Word255>
CMD_FAST_BLANK	0x1C Len=0x08	0x08 0x00+ Len	<Start Addr> <Stop Addr>
CMD_CRC	0x16	0x0C	<Start Addr> <Stop Addr> <CRC32>
CMD_FLAOP_EN	0x17	0x00	N/A
CMD_FLAOP_DIS	0x18	0x00	N/A
CMD_BOOTLOADER_STATE	0x19	0x00	N/A

Note:

<Addr> = <Byte0LSB> <Byte1> <Byte2> <Byte3MSB>

<Word>= <Byte0LSB> <Byte1> <Byte2> <Byte3MSB>

<CRC32>= <Byte0LSB> <Byte1> <Byte2> <Byte3MSB>

# HY16F Series

## ISP Bootloader Instruction Manual

### 3.3.5. ISP Command (Slave to Host) -(For HY16F198B & HY16F3981)

ISP ACK / NACK	Command Code	Data Length	Payload	Description
ACK_CMD_DONE	Return Host CMD Code	0x1	0xA4	Command Package is valid and has been executed.
ACK_PAGES_CS_TRUE	Return Host CMD Code	0x1	0xA5	For CMD 0x81: Expected Pages Checksum and Flash content is Consistent. For CMD 0x82: Expected Blank Sectors and Flash content is Consistent.
ACK_PAGES_CS_FAIL	Return Host CMD Code	0x1	0xA6	For CMD 0x81: Expected Pages Checksum and Flash content is Inconsistent For CMD 0x82: Expected Blank Sectors and Flash content is Inconsistent
NACK_CHECKSUM_ERR	Return Host CMD Code	0x1	0xE1	Command Package is invalid due to Checksum inconsistent.
NACK_READ_ERR	Return Host CMD Code	0x1	0xE2	Command Package is invalid due to data length inconsistent.
NACK_HEADER_ERR	Return Host CMD Code	0x1	0xE3	Command Package is invalid due to Header differ from <0x55><0xAA>

### 3.3.6. ISP Command (Slave to Host) -(For HY16F3910)

ISP ACK / NACK	Command Code	Data Length	Payload	Description
ACK_CMD_DONE	Return Host CMD Code	0x01	0xA4	Command Package is valid and has been executed.
ACK_PAGES_CS_TRUE	Return Host CMD Code	0x01	0xA5	<u>For CMD 0x1C:</u> Expected Pages Checksum and Flash content is Consistent.
ACK_PAGES_CS_FAIL	Return Host CMD Code	0x01	0xA6	<u>For CMD 0x1C:</u> Expected Pages Checksum and Flash content is Inconsistent
NACK_CHECKSUM_ERR	Return Host CMD Code	0x01	0xE1	Command Package is invalid due to Checksum inconsistent.
NACK_READ_ERR	Return Host CMD Code	0x01	0xE2	Command Package is invalid due to data length inconsistent.
NACK_HEADER_ERR	Return Host CMD Code	0x01	0xE3	Command Package is invalid due to Header differ from <0x55><0xAA>

### 3.3.7. Checksum calculation method- (For HY16F198B & HY16F3981)

Iteratively calculates all values by XOR, the value type is unsigned char, the final set value is 0xFF for XOR operation, and the return value is the final operation result.

Example 1 : Host to Slave=0x55, 0xAA, **0x97, 0x01, 0xA4, 0xCD**. Repeat the operation of 0x97, 0x01, 0xA4 with XOR, and finally insert 0xFF to do XOR operation to get 0xCD as the checksum value..

Example 2 : Host to Slave=0x55, 0xAA, **0x81, 0x01, 0xA5, 0xDA**. Repeat the operation of 0x81, 0x01, 0xA5 with XOR and finally insert 0xFF to do XOR operation to get 0xDA as the checksum value.

### 3.3.8. Checksum calculation method- (For HY16F3910)

Calculate checksum using CRC32.

Example 1 : Host to Slave=0x55, 0xAA, 0x19, 0x00, **0xE6**. 0xE6 is the checksum value

Example 2 : Host to Slave=0x55, 0xAA, 0x17, 0x00, **0xE8**. 0xE8 is the checksum value

### 3.3.9. ISP Command Package Transmission Example (For HY16F198B & HY16F3981)

Example:

1. The Host sends out the CMD Package, as shown in the figure below, which indicates that 1Page (128 Byte) data is written at the Flash Address 0x90000 with the command PAGE\_WRITE\_ONLY (0x97), and the Checksum is 0x38.

Take the following data as an example. If this section of data is expected to be written, the CMD Package will be as shown in the waveform diagram. Please pay attention to the order of the corresponding waveform diagrams of MSB and LSB in the written data.

	DATA1	DATA2																		
00000000h:	48	00	00	C2	92	00	92	00	40	00	00	09	40	00	00	09				
00000010h:	48	00	00	BF	92	00	92	00	40	00	00	09	40	00	00	09				
00000020h:	48	00	00	BE	92	00	92	00	40	00	00	09	40	00	00	09				
00000030h:	48	00	00	EA	92	00	92	00	40	00	00	09	40	00	00	09				
00000040h:	48	00	01	3F	92	00	92	00	40	00	00	09	40	00	00	09				
00000050h:	48	00	01	3B	92	00	92	00	40	00	00	09	40	00	00	09				
00000060h:	48	00	01	37	92	00	92	00	40	00	00	09	40	00	00	09				
00000070h:	48	00	01	33	92	00	92	00	40	00	00	09	40	00	00	09				
00000080h:	48	00	01	2F	92	00	92	00	40	00	00	09	40	00	00	09				

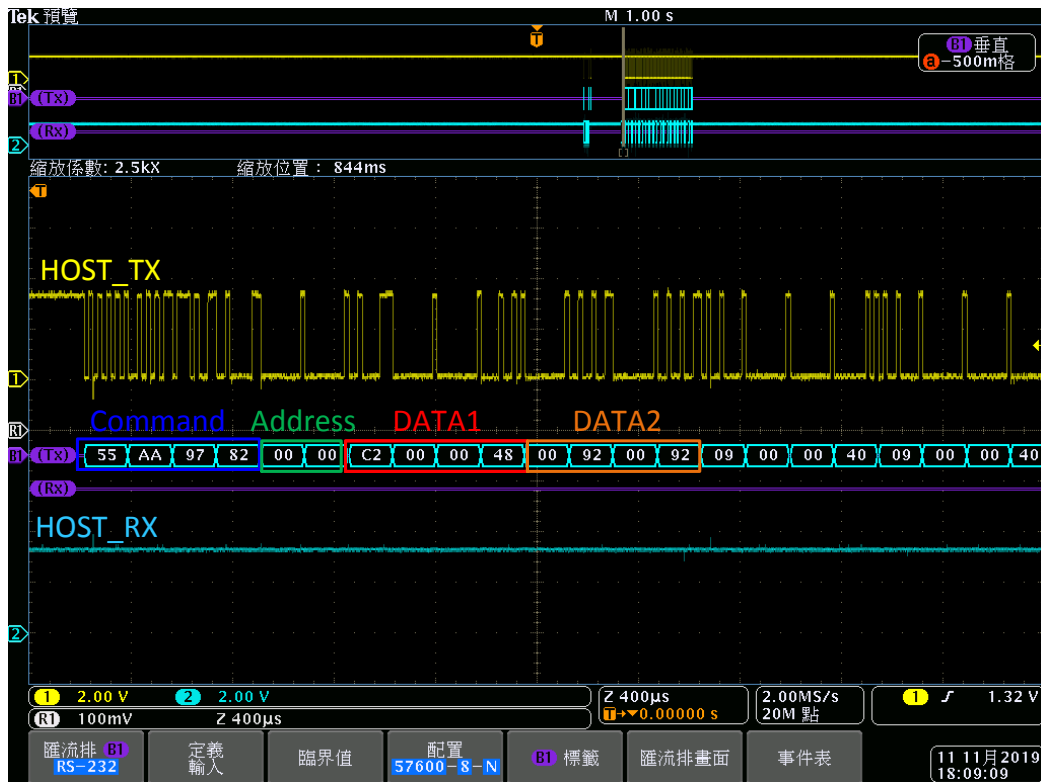

- Slave responds to CMD Package: CMD Code is the same as HOST, Data is ACK\_DONE (0xA4), indicating that CMD Package is correct, and the command has been executed, and the returned Checksum is 0xCD.

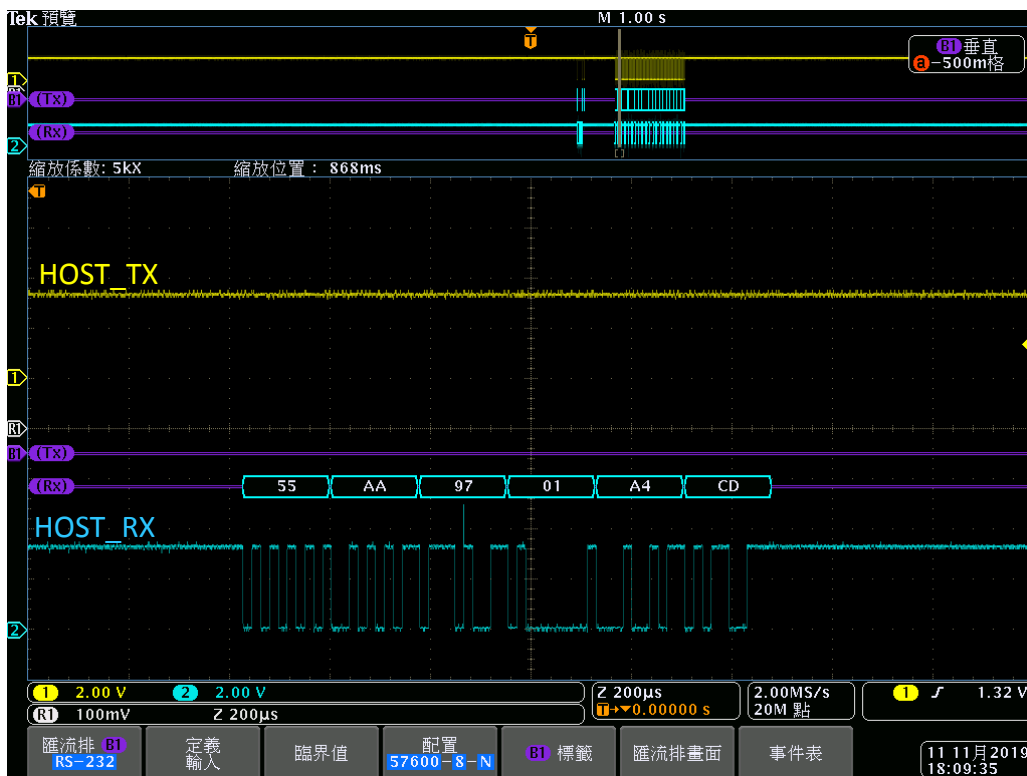

### 3.3.10. ISP Command Package Transmission Example (For HY16F3910)

Example 1:

Host sends CMD\_BOOTLOADER\_STATE command: 0x55, 0xAA, 0x19, 0x00, 0xE6, checksum is 0xE6

Slave returns 0x55, 0xAA, 0x19, 0x01, 0x00, 0xE7, checksum is 0xE7

Example 2:

Host sends CMD\_FLAOP\_EN command: 0x55, 0xAA, 0x17, 0x00, 0xE8, checksum is 0xE8

Slave returns 0x55, 0xAA, 0x17, 0x01, 0xA4, 0x4D, checksum is 0x4D

Example 3:

Host sends CMD\_MASS\_ERASE command: 0x55, 0xAA, 0x11, 0x00, 0xEE, checksum is 0xEE

Slave returns 0x55, 0xAA, 0x11, 0x01, 0xA4, 0x4B, checksum is 0x4B

### 4. ISP Bootloader Specification and Summary

#### Summary:

To use the ISP Bootloader, remember to set the ISP Resource Setting first. You can use the HY16F Writer to perform the “Enable” action of the Bootloader function. After the Bootloader function is enabled, the chip will first enter the Bootloader conditional judgment after power off & on. 4 Wire and 5-wire UART judgment methods are different. If 5-wire UART is used, and the default pins are TX(PT2.0)/RX(PT2.1)/ISP\_EN(PT2.2), then pay attention to the external design of PT2.0~PT2.2 Whether it conforms to the Bootloader application. To avoid misoperation, the Bootloader function cannot be executed normally. If you use a 4-wire UART, there is one less I/O than a 5-wire UART, which has advantages in application, but the control circuit using USB to UART is relatively complicated. The advantage of using HY-Bridge Board is that 2 external BJT circuits have been designed in the PCB board. It is relatively simple and convenient to use this PCB for testing and verification (it can be directly connected to pin to pin). Bootloader AP software, if you want to develop Bootloader AP software, you can refer to the description in Chapter 3.3 UART Protocol. The ISP Bootloader is to write the Bootloader FW in the Boot ROM, which will not occupy any Flash program space of the chip. Currently, the communication interface supported by the Bootloader mode is UART.

#### Specification:

The following are actual operating data specifications for reference.

Operating Voltage : 2.2~3.6V (HY16F19xB series and HY16F3981)

Burning time : HY16F198B & HY16F3981. Considering that the UART serial transfer rate is 115200sps to update 64KB, about 15.5sec.

Operating Voltage : 1.8~5.5V (HY16F3910)

Burning time : HY16F3910. Considering that the UART serial transfer rate is 115200sps to update 128KB, about 20sec.

**Note** : Due to the difference in the hardware configuration of the serial port (UART) on the computer, the above programming time may be longer than 5 seconds. This is a normal phenomenon. There is a problem with the non-HYCON Bootloader AP software and the HY16F chip.

# HY16F Series ISP Bootloader Instruction Manual

---



## 5. Revision History

Version	Page	Date	Revision Summary
V01	All	2022/09/01	First edition