



HY11P35
Datasheet
8-Bit RISC-like Mixed Signal Microcontroller
Embedded 4x32 LCD Driver
Low Noise Amplifier
18-Bit $\Sigma\Delta$ ADC

Table of Content

1. FEATURES	4
2. PIN DEFINITION	5
2.1 LQFP100 Pin Diagram	5
2.2 LQFP100 Pinout I/O Description.....	6
3. APPLICATION CIRCUIT	11
3.1 Bridge Sensor I	11
4. FUNCTION DESCRIPTION.....	12
4.1 Internal Block Diagram.....	12
4.2 Related Description and Supporting Documents.....	12
4.3 SD18 Network.....	13
4.4 Low Noise OPAMP Network.....	14
5. REGISTER LIST	15
6. ELECTRICAL CHARACTERISTICS.....	17
6.1 Recommended operating conditions.....	17
6.2 Internal RC Oscillator	18
6.3 Supply Current into VDD Excluding Peripherals Current.....	19
6.4 Port1~4.....	21
6.5 Reset (Brownout, External RST Pin, Low Voltage Detect).....	22
6.6 Power System.....	24
6.7 LCD.....	26
6.8 Low Noise OPAMP	27

HY11P35

**Embedded 18-Bit $\Sigma\Delta$ ADC
8-Bit RISC-like Mixed Signal Microcontroller**



6.9	SD18, Power Supply and Recommended Operating Conditions	28
6.10	Built-in EPROM (BIE)	33
7.	ORDERING INFORMATION	34
8.	PACKAGE INFORMATION	35
8.1	LQFP100(L100)	35
9.	REVISION RECORD	36

1. Features

- 8-bit RISC, 66 instructions included.
- Operating voltage range: 2.0V to 3.6V, operation temperature range: -40°C~85°C.
- External Crystal Oscillator and Internal High Precision RC Oscillator, 6 CPU clock rates enable users to have the most power-saving plan.
 - Active Mode 300uA@2MHz
 - Standby Mode 3uA@32KHz
 - Sleep Mode 1uA
- 6K Word OTP (One Time Programmable) Type Program Memory, 256 Byte Data Memory
- Brownout detector and Watch dog Timer, prevents CPU from Crash.
- 18-bit fully differential input Sigma-Delta Analog-to-Digital Converter (A/D)
 - Built-in PGA (Programmable Gain Amplifier) 1/4x、1/2x、1x、...128x、10 input signal gain selection.
 - Built-in Input zero point adjustment can increase measurement range according to different application.
 - Built-in absolute temperature sensor
- Ultra-Low Input Noise (<1uVpp) OP provides high output impedance, small signal amplification and low current voltage transformation
- 1.0V internal analog circuit common ground that equips with Push-Pull drive ability to provide sensor driving voltage.
- LVD low voltage detection function has 14 steps of voltage detection configuration and external input voltage detection function.
- Analog voltage source, VDDA equips with 10mA low dropout regulator function
- 4x32 LCD Driver
 - 1/4 Duty, 1/3 Bias
 - Built-in Charge Pump regulated circuit, providing 4 LCD Bias voltage
- 8-bit Timer A
- 16-bit Timer B module has Capture/Compare function.
- 8-bit Timer C module can generate PWM/PFD function.
- Built-in EPROM (BIE)
- Support 6 stack level

2. Pin Definition

2.1 LQFP100 Pin Diagram

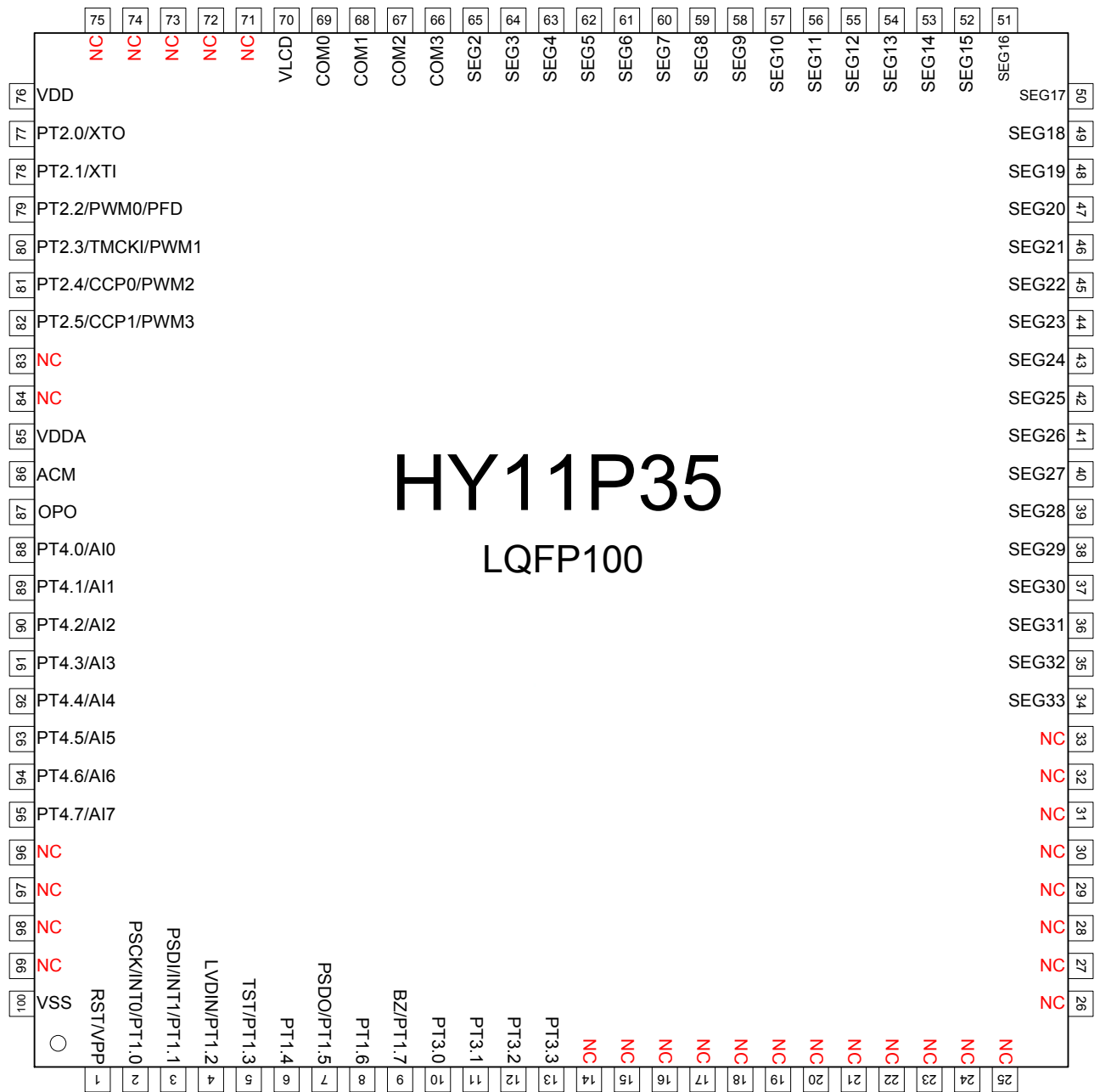

Figure 2-1 HY11P35 LQFP100 Pin Diagram

Note 1 : VPP and RST use the same pin. Input voltage cannot exceed 5.8V when not programming EPROM.

Note 2 : TST and PT1.3 use the same pin. Input voltage cannot exceed Vdd+0.3V while operating.

Note 3 : If PT1.3 is not configured as external pin button, it can help to enhance the anti-interference ability.

2.2 LQFP100 Pinout I/O Description

"I/O" input/output, "I" input, "O" output, "S" Smith Trigger, "C" CMOS features compatible input/output, "P" power supply, "A" analog channel

No.	Pin Name	Pin Characteristics		Function Description
		Pin Type	Buffer Type	
1	RST	I	S	Reset IC
	VPP	P	P	EPROM programming voltage input
2	PT1.0	I	S	Digital input
	INT0	I	S	Interrupt input INT0
	PSCK	I	S	OTP programming interface SCK
3	PT1.1	I	S	Digital input
	INT1	I	S	Interrupt input INT0
	PSDI	I	S	OTP programming interface SDI
4	PT1.2	I	S	Digital input
	LVDIN	A	A	LVD external signal input pin
5	PT1.3	I	S	Digital input
	TST	I	S	Test Mode input pin (invalid)
6	PT1.4	I/O	S	Digital I/O
7	PT1.5	I/O	S	Digital I/O
	PSDO	O	C	OTP programming interface SDO
8	PT1.6	I/O	S	Digital I/O
9	PT1.7	I/O	S	Digital I/O
	BZ	O	C	Buzzer input pin
10	PT3.0	I/O	C	Digital I/O
11	PT3.1	I/O	C	Digital I/O
12	PT3.2	I/O	C	Digital I/O
13	PT3.3	I/O	C	Digital I/O
14	NC	-	-	Unused
15	NC	-	-	Unused
16	NC	-	-	Unused

HY11P35

Embedded 18-Bit $\Sigma\Delta$ ADC 8-Bit RISC-like Mixed Signal Microcontroller

17	NC	-	-	Unused
18	NC	-	-	Unused
19	NC	-	-	Unused
20	NC	-	-	Unused
21	NC	-	-	Unused
22	NC	-	-	Unused
23	NC	-	-	Unused
24	NC	-	-	Unused
25	NC	-	-	Unused
26	NC	-	-	Unused
27	NC	-	-	Unused
28	NC	-	-	Unused
29	NC	-	-	Unused
30	NC	-	-	Unused
31	NC	-	-	Unused
32	NC	-	-	Unused
33	NC	-	-	Unused
34	SEG33	O	A	Segment output for LCD
35	SEG32	O	A	Segment output for LCD
36	SEG31	O	A	Segment output for LCD
37	SEG30	O	A	Segment output for LCD
38	SEG29	O	A	Segment output for LCD
39	SEG28	O	A	Segment output for LCD
40	SEG27	O	A	Segment output for LCD
41	SEG26	O	A	Segment output for LCD
42	SEG25	O	A	Segment output for LCD
43	SEG24	O	A	Segment output for LCD
44	SEG23	O	A	Segment output for LCD
45	SEG22	O	A	Segment output for LCD
46	SEG21	O	A	Segment output for LCD
47	SEG20	O	A	Segment output for LCD
48	SEG19	O	A	Segment output for LCD
49	SEG18	O	A	Segment output for LCD
50	SEG17	O	A	Segment output for LCD
51	SEG16	O	A	Segment output for LCD
52	SEG15	O	A	Segment output for LCD
53	SEG14	O	A	Segment output for LCD

HY11P35

Embedded 18-Bit Σ ADC 8-Bit RISC-like Mixed Signal Microcontroller

54	SEG13	O	A	Segment output for LCD	
55	SEG12	O	A	Segment output for LCD	
56	SEG11	O	A	Segment output for LCD	
57	SEG10	O	A	Segment output for LCD	
58	SEG9	O	A	Segment output for LCD	
59	SEG8	O	A	Segment output for LCD	
60	SEG7	O	A	Segment output for LCD	
61	SEG6	O	A	Segment output for LCD	
62	SEG5	O	A	Segment output for LCD	
63	SEG4	O	A	Segment output for LCD	
64	SEG3	O	A	Segment output for LCD	
65	SEG2	O	A	Segment output for LCD	
66	COM3	O	A	COM segment output for LDO	
67	COM2	O	A	COM segment output for LDO	
68	COM1	O	A	COM segment output for LDO	
69	COM0	O	A	COM segment output for LDO	
70	VLCD	P	P	Power supply for LCD	
71	NC	-	-	Unused	
72	NC	-	-	Unused	
73	NC	-	-	Unused	
74	NC	-	-	Unused	
75	NC	-	-	Unused	
76	VDD	P	P	Power supply for IC operation	
77	PT2.0/XTO	PT2.0	I/O	S	Digital I/O
		XTO	A	A	External Oscillator output pin
78	PT2.1/XTI	PT2.1	I/O	S	Digital I/O
		XTI	A	A	External Oscillator input pin
79	PT2.2/PWM0/PFD	PT2.2	I/O	C	Digital I/O
		PWM0	O	C	PWM0 output port
		PFD	O	C	PFD output port
80	PT2.3/TMCKI/PWM1	PT2.3	I/O	S	Digital I/O
		TMCKI	I	S	TIMERC clock source input port
		PWM1	O	C	PWM1 output port

81	PT2.4/CCP0/PWM2				
	PT2.4	I/O	S	Digital I/O	
	CCP0	I	S	Capture/Compare mode signal port	
	PWM2	O	C	PWM2 output port	
82	PT2.5/CCP1/PWM3				
	PT2.5	I/O	S	Digital I/O	
	CCP1	I	S	Capture/Compare mode signal port	
	PWM3	O	C	PWM3 output port	
83	NC		-	-	Unused
84	NC		-	-	Unused
85	VDDA		P	P	Regulator output, analog circuit power
86	ACM		P	P	Common ground pin for internal analog circuit
87	OPO		A	A	OPAMP output
88	PT4.0/AI0				
	PT4.0	I	C	Digital input	
	AI0	A	A	Analog input channel	
89	PT4.1/AI1				
	PT4.1	I	C	Digital input	
	AI1	A	A	Analog input channel	
90	PT4.2/AI2				
	PT4.2	I	C	Digital input	
	AI2	A	A	Analog input channel	
91	PT4.3/AI3				
	PT4.3	I	C	Digital input	
	AI3	A	A	Analog input channel	
92	PT4.4/AI4				
	PT4.4	I	C	Digital input	
	AI4	A	A	Analog input channel	
93	PT4.5/AI5				
	PT4.5	I	C	Digital input	
	AI5	A	A	Analog input channel	
94	PT4.6/AI6				
	PT4.6	I	C	Digital input	
	AI6	A	A	Analog input channel	
95	PT4.7/AI7				
	PT4.7	I	C	Digital input	
	AI7	A	A	Analog input channel	

HY11P35

Embedded 18-Bit $\Sigma\Delta$ ADC

8-Bit RISC-like Mixed Signal Microcontroller

96	NC	-	-	Unused
97	NC	-	-	Unused
98	NC	-	-	Unused
99	NC	-	-	Unused
100	VSS	P	P	Ground pin for IC operation voltage

Table 2-1 Pin Definition and Function Description

HY11P35

Embedded 18-Bit $\Sigma\Delta$ ADC
8-Bit RISC-like Mixed Signal Microcontroller



3. Application Circuit

3.1 Bridge Sensor I

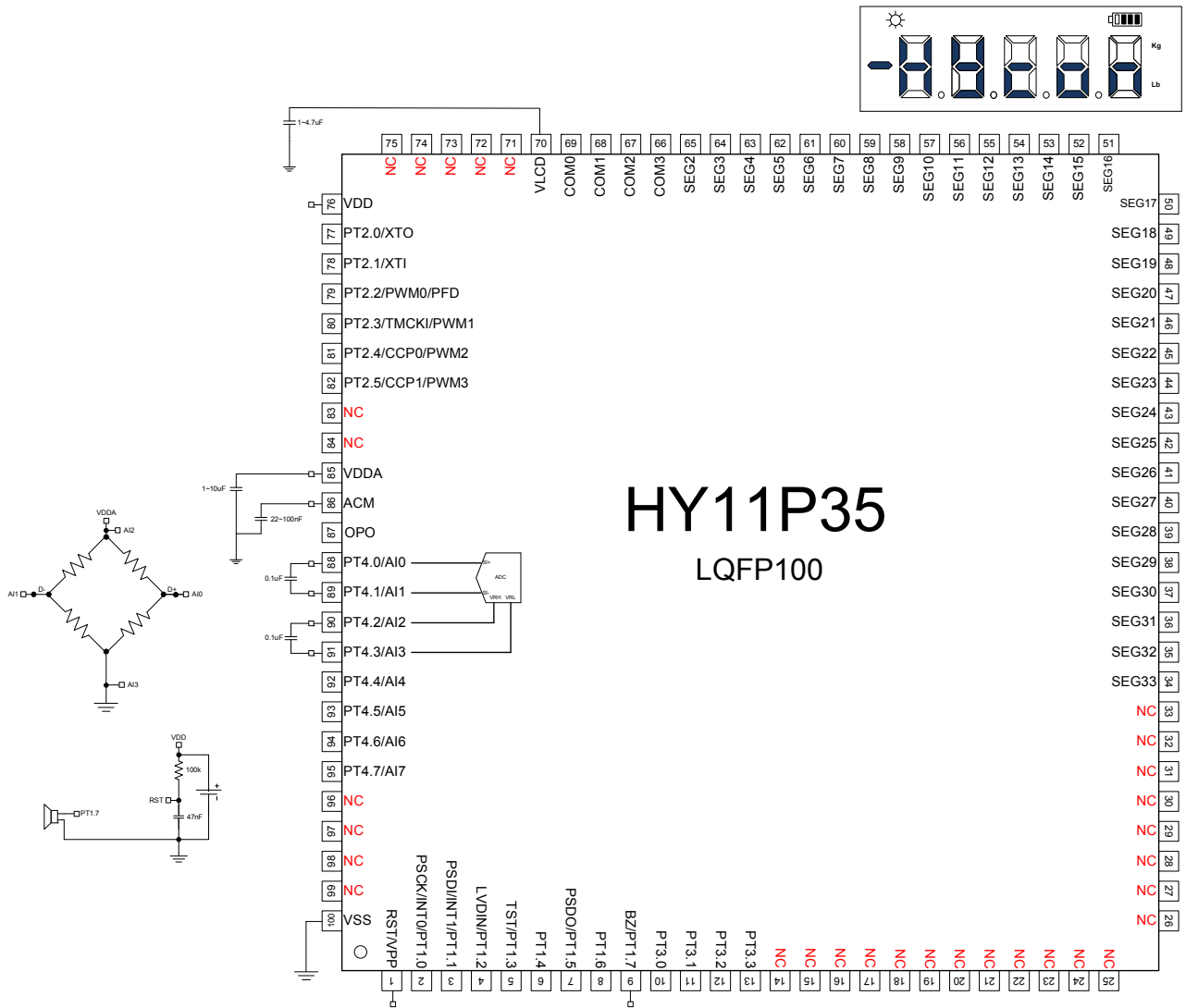
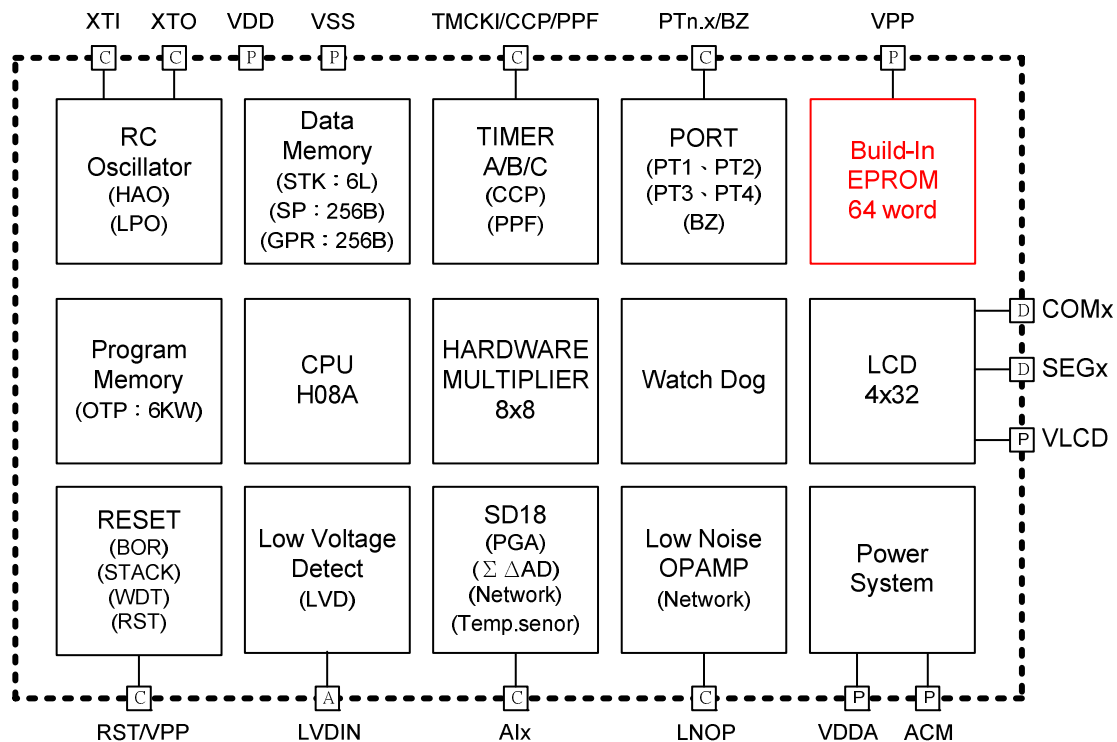

Figure 3-1 Application Circuit of Bridge Sensor

Note 1 : DCSET[2:0] can conduct bias adjustment of Load Cell zero point voltage address

4. Function Description

4.1 Internal Block Diagram



P Power Pad
 D Digital Pad
 A Analog Pad
 C Common I/O Pad

Figure 4-1 HY11P35 Internal Block Diagram

4.2 Related Description and Supporting Documents

IC Function Related Operating Instruction

- DS-HY11P35-Vxx HY11P35 Datasheet
- UG-HY11S14-Vxx HY11Pxx Series User's Manual
- APD-CORE002-Vxx H08A Instruction Description

Development Tool Related Operating Instruction

- APD-HYIDE006-Vxx HY11xxx Series Development Tool Software Instruction Manual
- APD-HYIDE005-Vxx HY11xxx Series Development Tool Hardware Instruction Manual
- APD-OTP001-Vxx OTP Products Programming Pin Manual

Product Production Related Operating Instruction

- APD-HYIDE004-Vxx HY1xxxx Series Production Line Specialized Programmer Manual
- BDI-HY11P35-Vxx HY11P35 Individual Product Die Bonding Information

4.3 SD18 Network

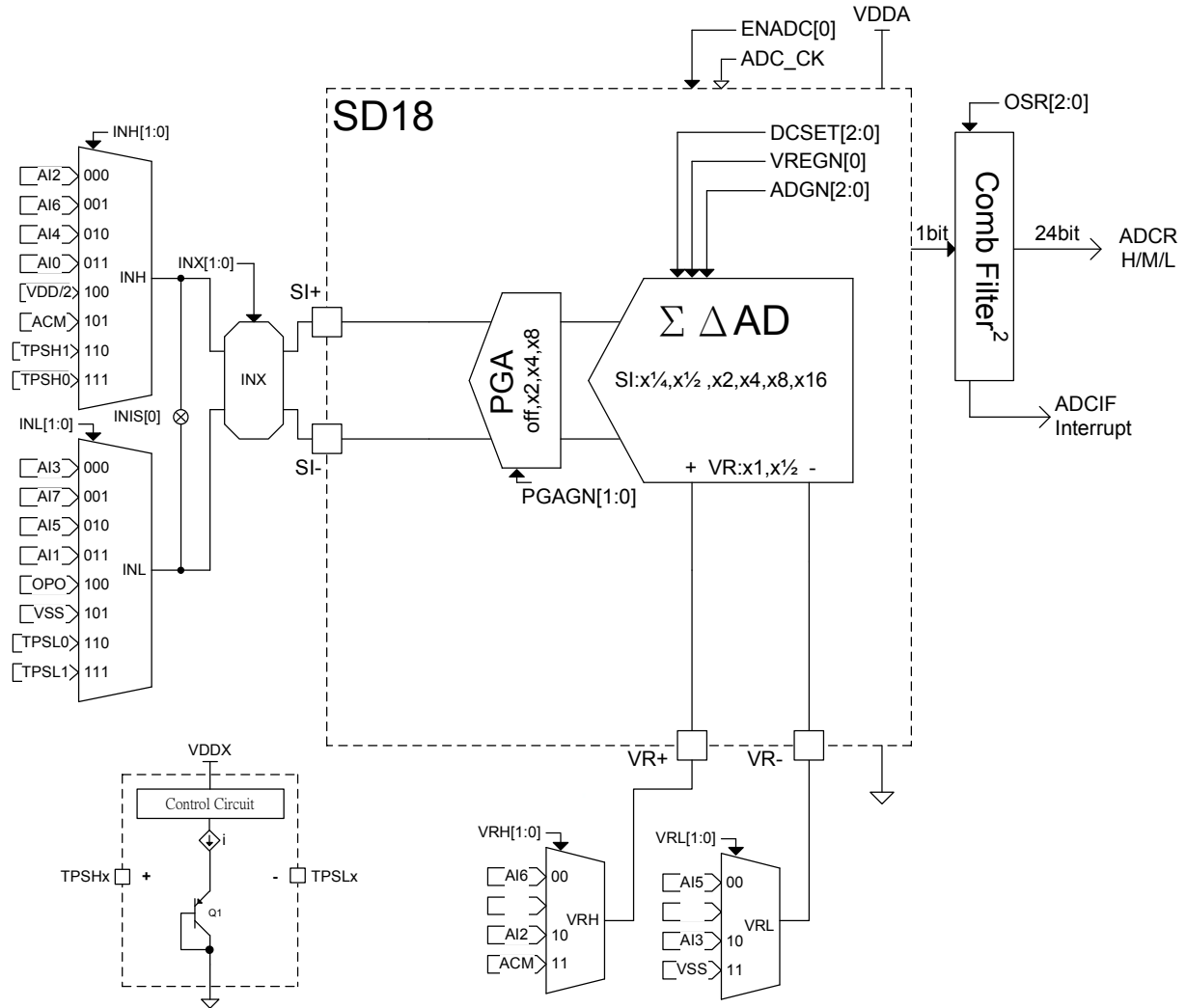

Figure 4-2 SD18 Network

4.4 Low Noise OPAMP Network

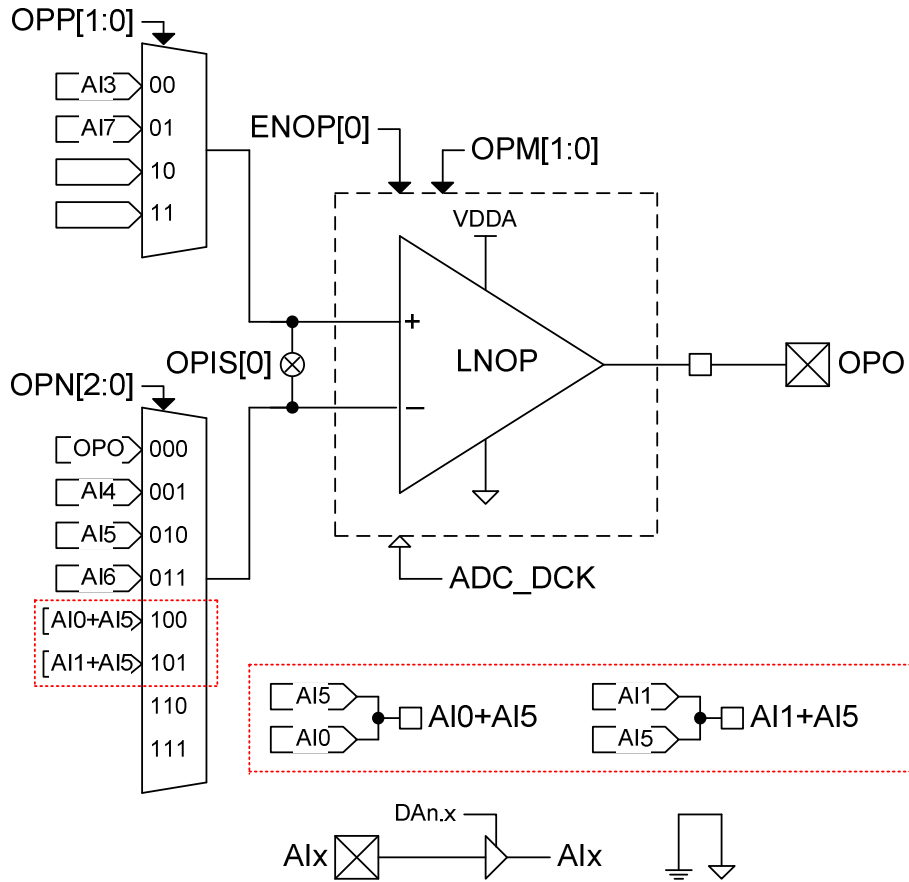

Figure 4-3 Low Noise OPAMP Network

5. Register List

Register File Summary for H08A

“.”no use, “*”read/write, “w”write, “r”read, “r0”only read 0, “r1”only read 1, “w0”only write 0, “w1”only write 1
 “.”unimplemented bit, “x”unknown, “u”unchanged, “d”depends on condition

Address	File Name	Bit7	Bit6	Bit5	Bit4	Bit3	Bit2	Bit1	Bit0	A-RESET	i-RESET	R/W
00H	INDF0	Contents of FSR0 to address data memory -value of FSR0 not changed								N/A	N/A	*****
01H	POINC0	Contents of FSR0 to address data memory -value of FSR0 post-incremented								N/A	N/A	*****
02H	PODEC0	Contents of FSR0 to address data memory -value of FSR0 post-decremented								N/A	N/A	*****
03H	PRINC0	Contents of FSR0 to address data memory -value of FSR0 pre-incremented								N/A	N/A	*****
04H	PLUSW0	Contents of FSR0 to address data memory -value of FSR0 offset by W								N/A	N/A	*****
05H	INDF1	Contents of FSR1 to address data memory -value of FSR0 not changed								N/A	N/A	*****
06H	POINC1	Contents of FSR1 to address data memory -value of FSR0 post-incremented								N/A	N/A	*****
07H	PODEC1	Contents of FSR1 to address data memory -value of FSR0 post-decremented								N/A	N/A	*****
08H	PRINC1	Contents of FSR1 to address data memory -value of FSR0 pre-incremented								N/A	N/A	*****
09H	PLUSW1	Contents of FSR1 to address data memory -value of FSR0 offset by W								N/A	N/A	*****
0FH	FSR0H							FSR0[9]	FSR0[8]xxuu
10H	FSR0L	Indirect Data Memory Address Pointer 0 Low Byte,FSR0[7:0]								xxxx xxxx	uuuu uuuu	*****
11H	FSR1H							FSR1[9]	FSR1[8]xxuu
12H	FSR1L	Indirect Data Memory Address Pointer 1 Low Byte,FSR1[7:0]								xxxx xxxx	uuuu uuuu	*****
16H	TOSH			TOS[13]	TOS[12]	TOS[11]	TOS[10]	TOS[9]	TOS[8]	..00 0000	..00 0000
17H	TOSL	Top-of-Stack Low Byte (TOS<7:0>)								0000 0000	0000 0000	*****
18H	STKPTR	STKFL	STKUN	STKOV		STKPRT[2]	STKPRT[1]	STKPRT[0]		000..000	000..000	r,rw0,rw0,-,r,r,r
1AH	PCLATH			PC[13]	PC[12]	PC[11]	PC[10]	PC[9]	PC[8]	..00 0000	..00 0000	*****
1BH	PCLATL	PC Low Byte for PC<7:0>								0000 0000	0000 0000	*****
1DH	TBLPTRH			TBLPTR[13]	TBLPTR[12]	TBLPTR[11]	TBLPTR[10]	TBLPTR[9]	TBLPTR[8]	..00 0000	..00 0000
1EH	TBLPTRL	Program Memory Table Pointer Low Byte (TBLPTR<7:0>)								0000 0000	0000 0000	*****
1FH	TBLDH	Program Memory Table Latch High Byte								0000 0000	0000 0000	*****
20H	TBLDL	Program Memory Table Latch Low Byte								0000 0000	0000 0000	*****
21H	PRODH	Product Register of Multiply High Byte								xxxx xxxx	uuuu uuuu	r,r,r,r,r,r,r,r
22H	PRODL	Product Register of Multiply Low Byte								xxxx xxxx	uuuu uuuu	r,r,r,r,r,r,r,r
23H	INTE1	GIE	ADCIE	TMCIIE	TMBIE	TMAIE	WDTIE	E1IE	E0IE	0000 0000	0000 0000	*****
24H	INTE2							CCP1IE	CCP0IE0000
26H	INTF1		ADCIF	TMCIF	TMBIF	TMAIF	WDTIF	E1IF	E0IF	..00 0000	..00 0000
27H	INTF2							CCP1IF	CCP0IF0000
29H	WREG	Working Register								xxxx xxxx	uuuu uuuu	*****
2AH	BSRCN								BSR[0]00
2BH	STATUS				C	DC	N	OV	Z	..x xxxx	..u uuuu
2CH	PSTATUS	PD	TO	IDLEB	BOR		SKERR			000d 0..	uduu d..	rw0,rw0,rw0,rw0,-,rw0,-
2DH	LVDON		LVDFG	LVD	LVDON				VLDX[3:0]	..00 0000	..00 0000
30H	PWRCN	ENVDDA		VDDAX[1:0]	ENACM					0000	0000	*****
31H	MCKCN1		ADCS[2:0]	ADCK	XTHSP	XTSP	ENXT	ENHAO		0000 0001	0000 0001	*****
32H	MCKCN2			LSCK	HSCK		HSS[1:0]	CPUCK[1:0]		..00 0000	..00 0000
33H	MCKCN3		LCDS[2:0]			PERCK		BZS[2:0]		000..0000	000..0000	*****
37H	OPCN1	ENOP		OPM[1:0]		OPP[1:0]		OPN[2:0]		0000 0000	0000 0000	*****
39H	ADCRH	ADC conversion memory HighByte								xxxx xxxx	uuuu uuuu	r,r,r,r,r,r,r,r
3AH	ADCRM	ADC conversion memory Middle Byte								xxxx xxxx	uuuu uuuu	r,r,r,r,r,r,r,r
3BH	ADCRL	ADC conversion memory Low Byte								xxxx xxxx	uuuu uuuu	r,r,r,r,r,r,r,r
3CH	ADCCN1	ENADC		ENCHP	PGAGN[1:0]			ADGN[2:0]		0000 0000	0000 0000	*****
3DH	ADCCN2			INBUF=0	VRBUF=0	VREGN		DCSET[2:0]		..00 0000	..00 0000	..,r0,r0 *****
3EH	ADCCN3		OSR[2:0]							000..	000..	*****
3FH	AINET1		INH[2:0]		INL[2:0]		INIS	OPIS		0000 0000	0000 0000	*****
40H	AINET2		VRH[1:0]		INX[1:0]		VRL[1:0]			..000 000.	..000 000.
41H	TMACN	ENTMA	TMACK	TMAS[1:0]		ENWDT		WDTS[2:0]		0000 0000	0000 0000	***** w1,*****
42H	TMAR	TimerA data register								xxxx xxxx	uuuu uuuu	r,r,r,r,r,r,r,r
43H	TMCN	ENTMB	TMBCK	TMBS[1:0]	TMBSYC	TMBR2R				0000 00..	0000 00..	*****
44H	TMBRH	TimerB High Byte data register								xxxx xxxx	uuuu uuuu	*****
45H	TMBRL	TimerB Low Byte data register								xxxx xxxx	uuuu uuuu	*****
46H	TMCCN	ENTMC	TMCCK[1:0]		TMCS[1:2:0]		TMCS0[1:0]			0000 0000	0000 0000	*****
47H	PRC	TimerC programmable register								1111 1111	1111 1111	*****
48H	TMCR	TimerC register								0000 0000	0000 0000	r,r,r,r,r,r,r,r
49H	CCPCN		CCP1M[3:0]				CCP0M[3:0]			0000 0000	0000 0000	*****
4AH	CCP0RH	CCP0 High Byte data register								xxxx xxxx	uuuu uuuu	*****
4BH	CCP0RL	CCP0 Low Byte data register								xxxx xxxx	uuuu uuuu	*****
4CH	CCP1RH	CCP1 High Byte data register								xxxx xxxx	uuuu uuuu	*****
4DH	CCP1RL	CCP1 Low Byte data register								xxxx xxxx	uuuu uuuu	*****
4EH	PASC	PASF		PASCF[1:0]		PSSCN0[1:0]		PSSCN1[1:0]		0.00 0000	0.00 0000	*****
4FH	PWMCN	ENPWM	ENPFD	PWMRL[1:0]		PWMC[1:0]		PWMM[1:0]		0000 0000	0000 0000	*****
50H	PDBD	ENPRS				DBDC[6:0]				0000 0000	0000 0000	*****
51H	PWMR	PWM MSB Byte register								xxxx xxxx	uuuu uuuu	*****

Table 5-1(a) HY11P35 Register List

HY11P35

Embedded 18-Bit Σ ADC 8-Bit RISC-like Mixed Signal Microcontroller



Register File Summary for H08A

"-"no use,"*"read/write,"w"write,"r"read,"r0"only read 0,"r1"only read 1,"w0"only write 0,"w1"only write 1 "u"unimplemented bit,"x"unknown,"u"unchanged,"d"depends on condition														
Address	File Name	Bit7	Bit6	Bit5	Bit4	Bit3	Bit2	Bit1	Bit0	A-RESET	I-RESET	R/W		
52H	LCDCN1	ENLCD	LC DPR	VLCDX[1:0]		LCDBF	LCDBI[1:0]=10			0000 010.	0000 010.	* ** * r1, r0, -		
53H	LCDCN2	LCDBL	LC DMX[1:0]=11							011.	011.	* r1, r1, -		
54H	LCD0	Segment SEG2@[3:0] and SEG3@[7:4] data register of LCD								xxxx xxxx	uuuu uuuu	* ** * ** *		
55H	LCD1	Segment SEG4@[3:0] and SEG5@[7:4] data register of LCD								xxxx xxxx	uuuu uuuu	* ** * ** *		
56H	LCD2	Segment SEG6@[3:0] and SEG7@[7:4] data register of LCD								xxxx xxxx	uuuu uuuu	* ** * ** *		
57H	LCD3	Segment SEG8@[3:0] and SEG9@[7:4] data register of LCD								xxxx xxxx	uuuu uuuu	* ** * ** *		
58H	LCD4	Segment SEG10@[3:0] and SEG11@[7:4] data register of LCD								xxxx xxxx	uuuu uuuu	* ** * ** *		
59H	LCD5	Segment SEG12@[3:0] and SEG13@[7:4] data register of LCD								xxxx xxxx	uuuu uuuu	* ** * ** *		
5AH	LCD6	Segment SEG14@[3:0] and SEG15@[7:4] data register of LCD								xxxx xxxx	uuuu uuuu	* ** * ** *		
5BH	LCD7	Segment SEG16@[3:0] and SEG17@[7:4] data register of LCD								xxxx xxxx	uuuu uuuu	* ** * ** *		
5CH	LCD8	Segment SEG18@[3:0] and SEG19@[7:4] data register of LCD								xxxx xxxx	uuuu uuuu	* ** * ** *		
5DH	LCD9	Segment SEG20@[3:0] and SEG21@[7:4] data register of LCD								xxxx xxxx	uuuu uuuu	* ** * ** *		
6AH	PT4	PT4.7	PT4.6	PT4.5	PT4.4	PT4.3	PT4.2	PT4.1	PT4.0	xxxx xxxx	uuuu uuuu	r, r, r, r, r, r		
6BH	PT4DA	DA4.7	DA4.6	DA4.5	DA4.4	DA4.3	DA4.2	DA4.1	DA4.0	1111 1111	1111 1111	* ** * ** *		
6CH	PT4PU	PU4.7	PU4.6	PU4.5	PU4.4	PU4.3	PU4.2	PU4.1	PU4.0	0000 0000	0000 0000	* ** * ** *		
6DH	PT1	PT1.7	PT1.6	PT1.5	PT1.4	PT1.3	PT1.2	PT1.1	PT1.0	xxxx xxxx	uuuu uuuu	* ** * r, r, r, r		
6EH	TRISC1	TC1.7	TC1.6	TC1.5	TC1.4					0000	0000	* ** *		
6FH	PT1DA					DA1.2				... 0..	... 0..	* ** *		
70H	PT1PU	PU1.7	PU1.6	PU1.5	PU1.4	PU1.3	PU1.2	PU1.1	PU1.0	0000 0000	0000 0000	* ** * ** *		
71H	PT1M1					INTEG1[1:0]		INTEG0[1:0]		... 0000	... 0000	* ** * ** *		
72H	PT1M2		PM1.7[0]							.0.0.	* ** *		
74H	PT2			PT2.5	PT2.4	PT2.3	PT2.2	PT2.1	PT2.0	..xx xxxx	..uu uuuu	* ** * ** *		
75H	TRISC2			TC2.5	TC2.4	TC2.3	TC2.2	TC2.1	TC2.0	..00 0000	..00 0000	* ** * ** *		
77H	PT2PU			PU2.5	PU2.4	PU2.3	PU2.2	PU2.1	PU2.0	..00 0000	..00 0000	* ** * ** *		
78H	PT2M1		PM2.3[0]	PM2.2[1]	PM2.2[0]					..0000	* ** *		
79H	PT2M2	PWMTR[1]	PWMTR[0]			PM2.5[1]	PM2.5[0]	PM2.4[1]	PM2.4[0]	00.. 0000	00.. 0000	* ** * ** *		
7AH	PT3					PT3.3	PT3.2	PT3.1	PT3.0	... xxxx	... uuuu	* ** * ** *		
7BH	TRISC3					TC3.3	TC3.2	TC3.1	TC3.0	... 0000	... 0000	* ** * ** *		
7DH	PT3PU					PU3.3	PU3.2	PU3.1	PU3.0	... 0000	... 0000	* ** * ** *		
80H ~ FFH	GPR0	General Purpose Register as 128Byte								xxxx xxxx	uuuu uuuu	* ** * ** *		
100H ~ 17FH	GPR1	General Purpose Register as 128Byte								xxxx xxxx	uuuu uuuu	* ** * ** *		
180H	LCD10	Segment SEG22@[3:0] and SEG23@[7:4] data register of LCD								xxxx xxxx	uuuu uuuu	* ** * ** *		
181H	LCD11	Segment SEG24@[3:0] and SEG25@[7:4] data register of LCD								xxxx xxxx	uuuu uuuu	* ** * ** *		
182H	LCD12	Segment SEG26@[3:0] and SEG27@[7:4] data register of LCD								xxxx xxxx	uuuu uuuu	* ** * ** *		
183H	LCD13	Segment SEG28@[3:0] and SEG29@[7:4] data register of LCD								xxxx xxxx	uuuu uuuu	* ** * ** *		
184H	LCD14	Segment SEG30@[3:0] and SEG31@[7:4] data register of LCD								xxxx xxxx	uuuu uuuu	* ** * ** *		
185H	LCD15	Segment SEG32@[3:0] and SEG33@[7:4] data register of LCD								xxxx xxxx	uuuu uuuu	* ** * ** *		
195H	BICTRL					VPP_HIGH		BIEWR	BIERD	1000 d000	1000 d000	* ** * r, r, *		
197H	BICTRL	0	0	BIE_ADDR[5:0]								0000 0000	0000 0000	w0, w0, * ** * ** *
198H	BIEDH	BIE_DATA[15:8]								xxxx xxxx	xxxx xxxx	* ** * ** *		
199H	BIEDL	BIE_DATA[7:0]								xxxx xxxx	xxxx xxxx	* ** * ** *		

Table 5-1(b) HY11P35 Register List (Continued)

6. Electrical Characteristics

Absolute maximum ratings over operating free-air temperature (unless otherwise noted)

Voltage applied at V_{DD} to V_{SS}	-0.2 V to 4.0 V
Voltage applied to any pin	-0.2 V to $V_{DD} + 0.3$ V
Voltage applied to RST/VPP pin	-0.2 V to 6.9 V
Voltage applied to TST/PT1.3 pin	-0.2 V to $V_{DD} + 1$ V
Diode current at any device terminal	± 2 mA
Storage temperature, Tstg: (unprogrammed device)	-55°C to 150°C
(programmed device)	-40°C to 85°C
Total power dissipation	0.5w
Maximum output current sink by any PORT1 to PORT3 I/O pin	.25mA

6.1 Recommended Operating Conditions

$T_A = -40^\circ\text{C} \sim 85^\circ\text{C}$, unless otherwise noted

Sym.	Parameter		Test Conditions	Min.	Typ.	Max.	unit	
V_{DD}	Supply Voltage		All digital peripherals and CPU	2.2		3.6	V	
			Analog peripherals	2.4		3.6		
V_{SS}	Supply Voltage			0		0		
XT	External	Watch crystal	$V_{DD} = 2.2\text{V}$, ENXT[0]=1		32.768K		Hz	
	Oscillator	Ceramic resonator		XTSP[0]=0, XTHSP[0]=0				
		Crystal		XTSP[0]=1, XTHSP[0]=0	450K			8M
Frequency			XTSP[0]=1, XTHSP[0]=0	1M		8M		

6.2 Internal RC Oscillator

$T_A = 25^\circ\text{C}, V_{DD} = 3.0\text{V}$, unless otherwise noted

Sym.	Parameter	Test Conditions	Min.	Typ.	Max.	unit
HAO	High Speed Oscillator frequency	ENHAO[0]=1	1.8	2.0	2.2	MHz
LPO	Low Power Oscillator frequency	V_{DD} supply voltage be enable LPO	22	28	35	KHz

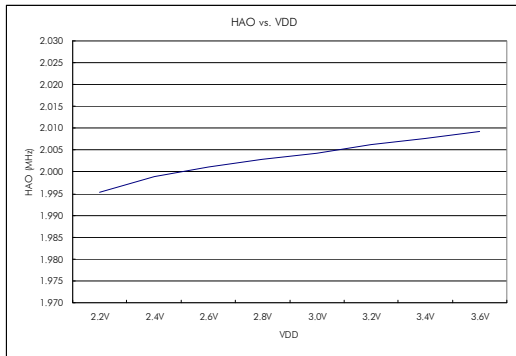

Figure 6.2-1 HAO vs. VDD

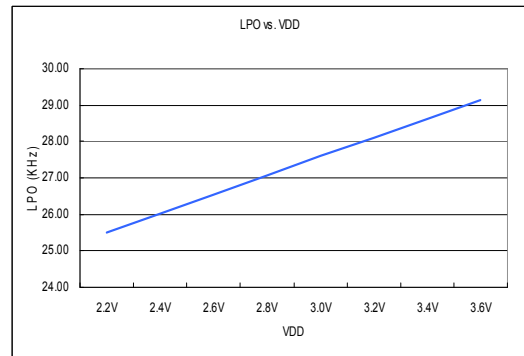

Figure 6.2-2 LPO vs. VDD

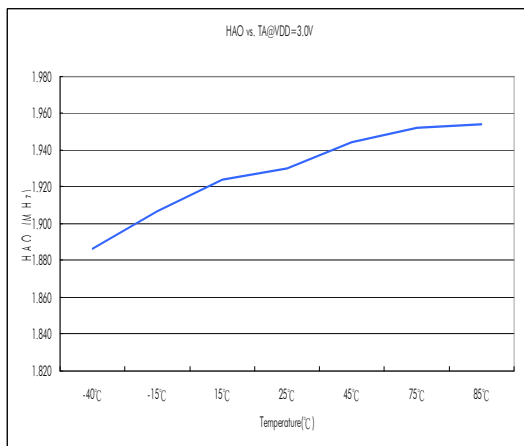

Figure 6.2-3 HAO vs. Temperature

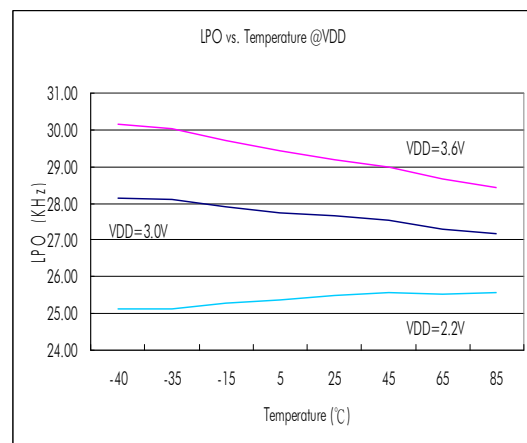

Figure 6.2-4 LPO vs. Temperature

6.3 Supply Current into VDD Excluding Peripherals Current

$T_A = 25^\circ\text{C}, V_{DD} = 3.0\text{V}, \text{OSC_LPO} = 28\text{KHz}$, unless otherwise noted

Sym.	Parameter	Test Conditions	Min.	Typ.	Max.	unit
I_{AM1}	Active mode 1	OSC_CY = 8MHz, OSC_HAO = off, CPU_CK = 8MHz		1.34	2	mA
I_{AM2}	Active mode 2	OSC_CY = off, OSC_HAO = 2MHz, CPU_CK = 2MHz		0.36	0.55	mA
I_{AM3}	Active mode 3	OSC_CY = off, OSC_HAO = 2MHz, CPU_CK = 1MHz		0.2	0.3	mA
I_{LP1}	Low Power 1	OSC_CY = 32768Hz, OSC_HAO = off, CPU_CK = 16384Hz		7	12	μA
I_{LP2}	Low Power 2	OSC_CY = off, OSC_HAO = off, CPU_CK = LPO, Idle state		1.65	3	μA
I_{LP3}	Low Power 3	OSC_CY = off, OSC_HAO = off, CPU_CK = off, Sleep state		0.65	1.2	μA

OSC_CY : External Oscillator frequency.

OSC_HAO : Internal High Accuracy Oscillator frequency.

CPU_CK : CPU core work frequency.

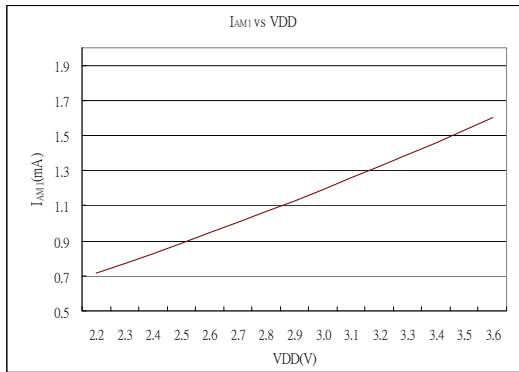

Figure 6.3-1 I_{AM1} vs. VDD

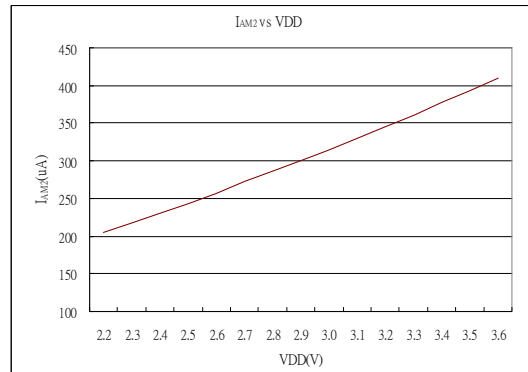

Figure 6.3-2 I_{AM2} vs. VDD

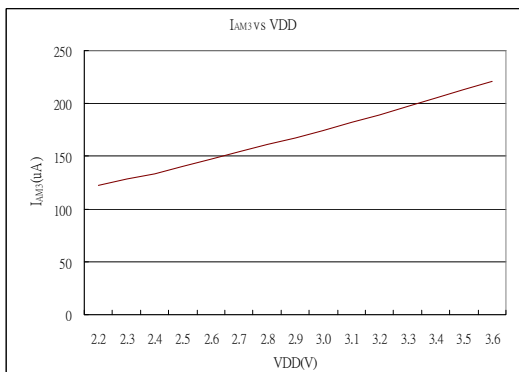

Figure 6.3-3 I_{AM3} vs. VDD

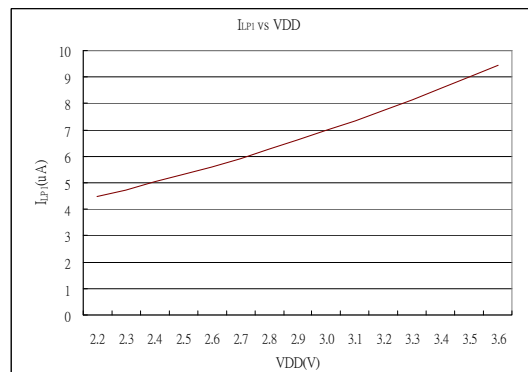

Figure 6.3-4 I_{LP1} vs. VDD

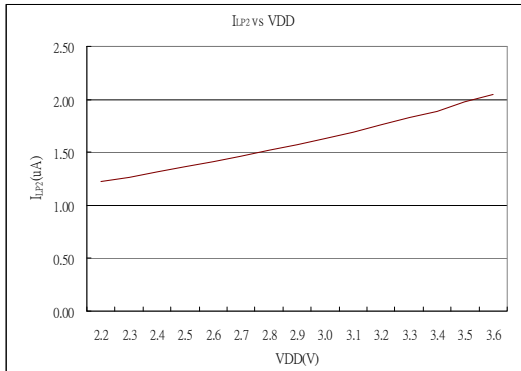

Figure 6.3-5 I_{LP2} vs. VDD

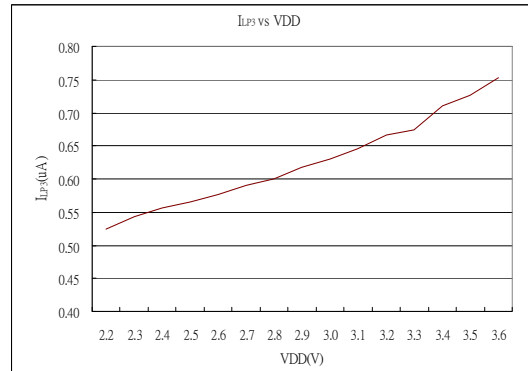

Figure 6.3-6 I_{LP3} vs. VDD

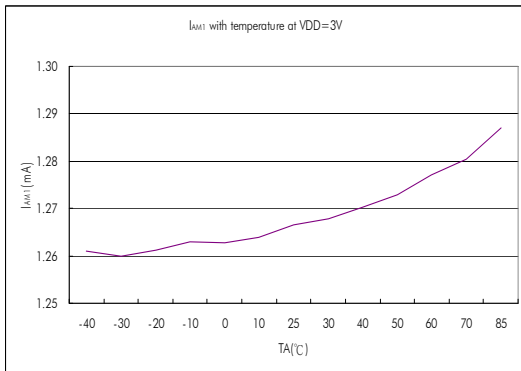

Figure 6.3-7 I_{AM1} vs. Temperature

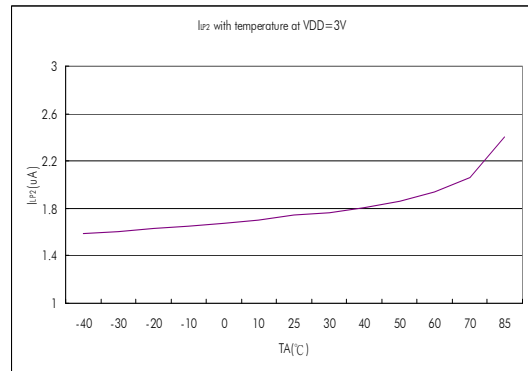

Figure 6.3-8 I_{LP2} vs. Temperature

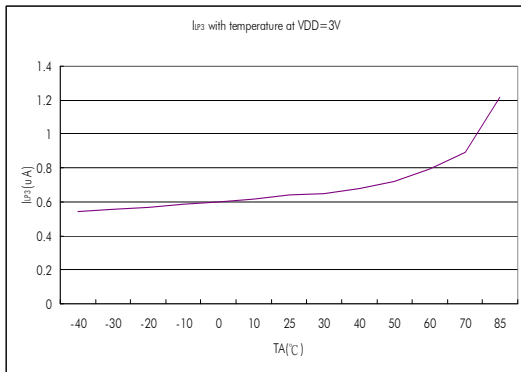

Figure 6.3-9 I_{LP3} vs. Temperature

6.4 Port1~4

$T_A = 25^\circ\text{C}, V_{DD} = 3.0\text{V}$, unless otherwise noted

Sym.	Parameter	Test Conditions	Min.	Typ.	Max.	unit
Input voltage and Schmitt trigger and leakage current and timing						
V_{IH}	High-Level input voltage				2.1	V
V_{IL}	Low-Level input voltage		0.9			
V_{hys}	Input Voltage hysteresis($V_{IH} - V_{IL}$)			0.8		V
I_{LKG}	Leakage Current				0.1	μA
R_{PU}	Port pull high resistance			180		$\text{k}\Omega$
Output voltage and current and frequency						
V_{OH}	High-level output voltage	$I_{OH}=10\text{mA}$	$V_{DD} - 0.3$			V
V_{OL}	Low-level output voltage	$I_{OL}=-10\text{mA}$			$V_{SS} + 0.3$	

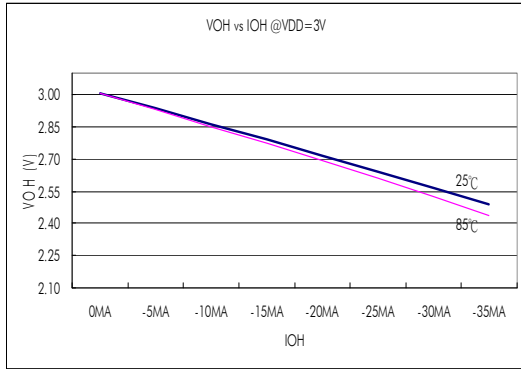

Figure 6.4-1 V_{OH} vs. I_{OH} @ $V_{DD}=3.0\text{V}$

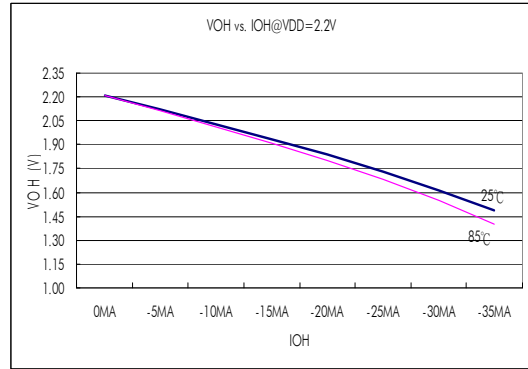

Figure 6.4-2 V_{OH} vs. I_{OH} @ $V_{DD}=2.2\text{V}$

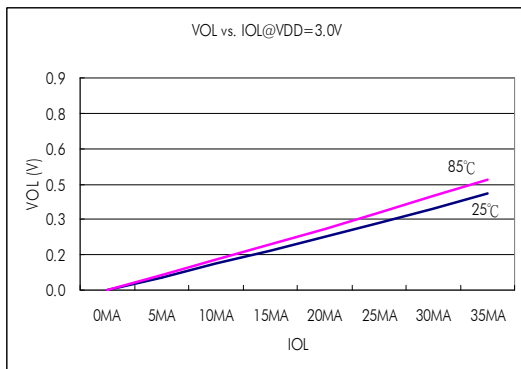

Figure 6.4-3 V_{OL} vs. I_{OL} @ $V_{DD}=3.0\text{V}$

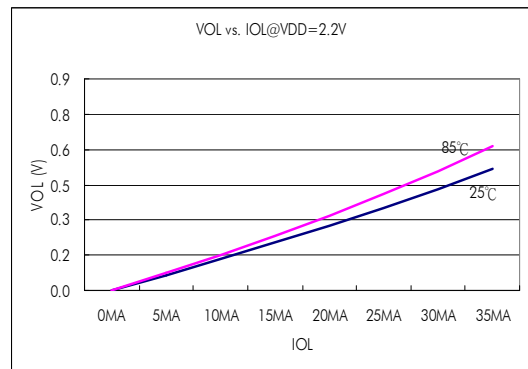

Figure 6.4-4 V_{OL} vs. I_{OL} @ $V_{DD}=2.2\text{V}$

6.5 Reset (Brownout, External RST Pin, Low Voltage Detect)

$T_A = 25^\circ\text{C}, V_{DD} = 3.0\text{V}$, unless otherwise noted

Sym.	Parameter	Test Conditions	Min.	Typ.	Max.	unit
BOR	Pulse length needed to accepted reset internally, t_{d-LVR}		2			us
	V_{DD} Start Voltage to accepted reset internally (L→H), V_{LVR}		1.6	1.85	2.1	V
	Hysteresis, $V_{HYS-LVR}$			70		mV
RST	Pulse length needed as RST/VPP pin to accepted reset internally, t_{d-RST}		2			us
	Input Voltage to accepted reset internally		0.9			V
	Hysteresis, $V_{HYS-RST}$			0.8		V
LVD	Operation current, I_{LVD}			10	15	uA
	External input voltage to compare reference voltage			1.2		V
	Compare reference voltage temperature drift	$T_A = -40^\circ\text{C} \sim 85^\circ\text{C}$		100		ppm/ $^\circ\text{C}$
	Detect V_{DD} voltage error			2		%
	Detect V_{DD} voltage rang by user option, $V_{SVS} VLDx[3:0]=1110b$			3.3		V
	Detect V_{DD} voltage rang by user option, $V_{SVS} VLDx[3:0]=1101b$			3.2		
	Detect V_{DD} voltage rang by user option, $V_{SVS} VLDx[3:0]=1100b$			3.1		
	Detect V_{DD} voltage rang by user option, $V_{SVS} VLDx[3:0]=1011b$			3.0		
	Detect V_{DD} voltage rang by user option, $V_{SVS} VLDx[3:0]=1010b$			2.9		
	Detect V_{DD} voltage rang by user option, $V_{SVS} VLDx[3:0]=1001b$			2.8		
	Detect V_{DD} voltage rang by user option, $V_{SVS} VLDx[3:0]=1000b$			2.7		
	Detect V_{DD} voltage rang by user option, $V_{SVS} VLDx[3:0]=0111b$			2.6		
	Detect V_{DD} voltage rang by user option, $V_{SVS} VLDx[3:0]=0110b$			2.5		
	Detect V_{DD} voltage rang by user option, $V_{SVS} VLDx[3:0]=0101b$			2.4		
	Detect V_{DD} voltage rang by user option, $V_{SVS} VLDx[3:0]=0100b$			2.3		
	Detect V_{DD} voltage rang by user option, $V_{SVS} VLDx[3:0]=0011b$			2.2		
	Detect V_{DD} voltage rang by user option, $V_{SVS} VLDx[3:0]=0010b$			2.1		
Detect V_{DD} voltage rang by user option, $V_{SVS} VLDx[3:0]=0001b$			2.0			

BOR : Brownout Reset

LVR : Low Voltage Reset of BOR

LVD : Low Voltage Detect

RST : External Reset pin

HY11P35

Embedded 18-Bit $\Sigma\Delta$ ADC
8-Bit RISC-like Mixed Signal Microcontroller

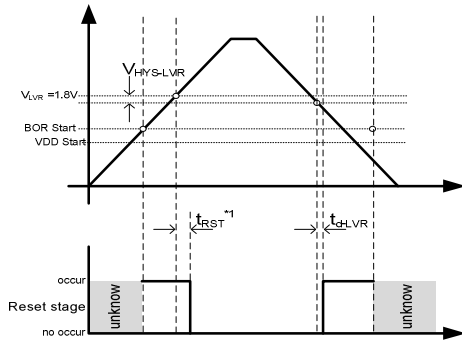

Figure 6.5-1 BOR reset diagram

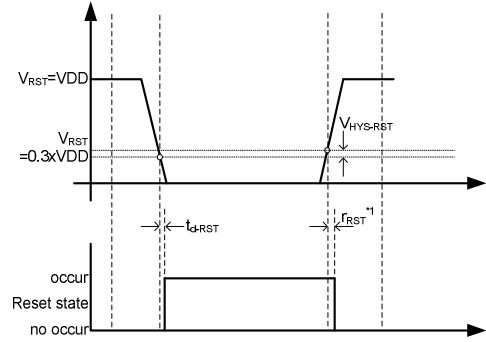

Figure 6.5-2 RST reset diagram

*1 t_{RST} : Please see BOR Introduce of HY11Pxx series User's Guide (UG-HY11S14-Vxx).

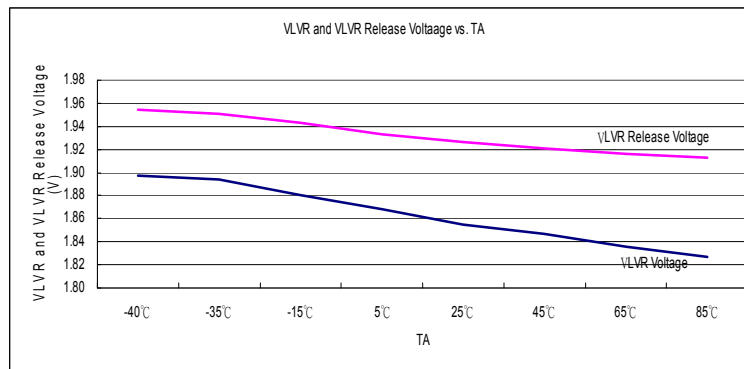

Figure 6.5-3 LVR vs. Temperature

6.6 Power System

$T_A = 25^\circ\text{C}, V_{DD} = 3.0\text{V}$, unless otherwise noted

Sym.	Parameter	Test Conditions		Min.	Typ.	Max.	unit
VDDA	VDDA operation current, I_{VDDA}	$I_L = 0\text{mA}$	VDDAX[1:0]=00b	22			μA
	Select VDDA output voltage	$I_L = 0.1\text{mA}$, $V_{DD} \geq V_{VDDA} + 0.2\text{V}$	VDDAX[1:0]=00b	3.3			V
			VDDAX[1:0]=01b	2.9			V
			VDDAX[1:0]=10b	2.6			V
			VDDAX[1:0]=11b	2.4			V
	Dropout voltage	$I_L = 10\text{mA}$	VDDAX[1:0]=00b	135			mV
			VDDAX[1:0]=01b	150			mV
			VDDAX[1:0]=10b	165			mV
			VDDAX[1:0]=11b	180			mV
	Temperature drift	VDDX[1:0]=11b	$T_A = -40^\circ\text{C} \sim 85^\circ\text{C}$	50			ppm/ $^\circ\text{C}$
V_{DD} Voltage drift	$I_L = 0.1\text{mA}$	$V_{DD} = 2.5\text{V} \sim 3.6\text{V}$	± 0.2			%/V	
ACM	ACM operation current, I_{ACM}	$I_L = 0\text{mA}$		20			μA
	Output voltage, V_{ACM}	ENACM[0]=1	$I_L = 0\mu\text{A}$	1.0			V
	Output voltage with Load		$I_L = \pm 200\mu\text{A}$	0.98	1.02		V_{ACM}
	Temperature drift	ENACM[0]=1,	$T_A = -40^\circ\text{C} \sim 85^\circ\text{C}$	50			ppm/ $^\circ\text{C}$
	VDDA Voltage drift	$I_L = 10\mu\text{A}$		100			$\mu\text{V}/\text{V}$

VDDA : Adjust Voltage Regulator
ACM : Analog Common Voltage

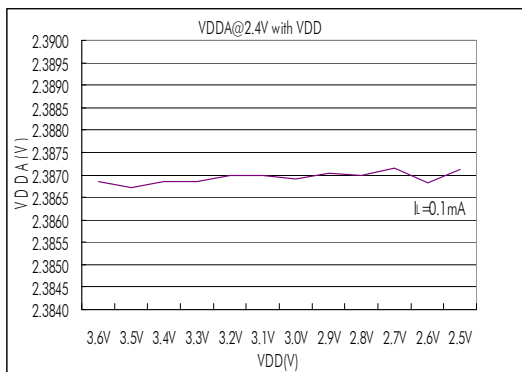

Figure 6.6-1 VDDA $I_L = 0.1\text{mA}$ vs. VDD

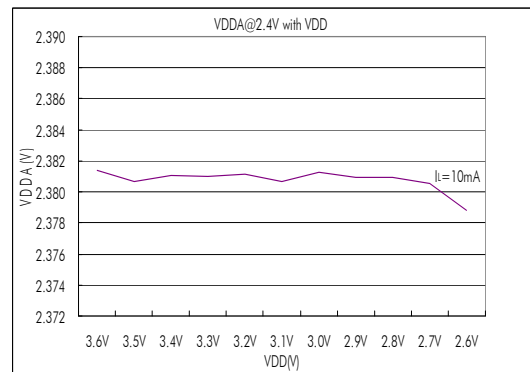

Figure 6.6-2 VDDA $I_L = 10\text{mA}$ vs. VDD

HY11P35

Embedded 18-Bit Σ ADC 8-Bit RISC-like Mixed Signal Microcontroller

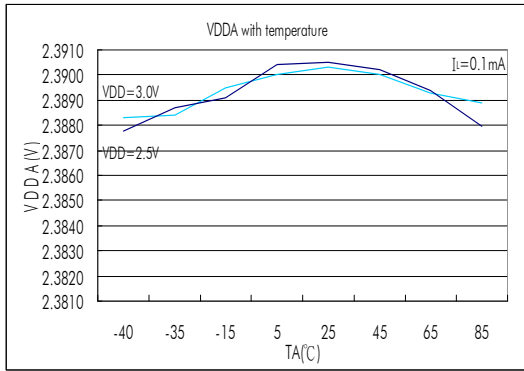

Figure 6.6-3 VDDA $I_L=0.1\text{mA}$ vs. VDD

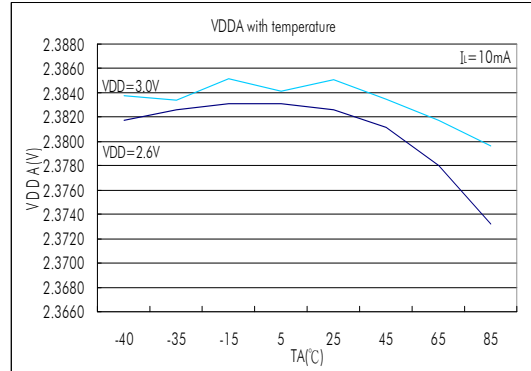

Figure 6.6-4 VDDA $I_L=0.1\text{mA}$ vs. VDD

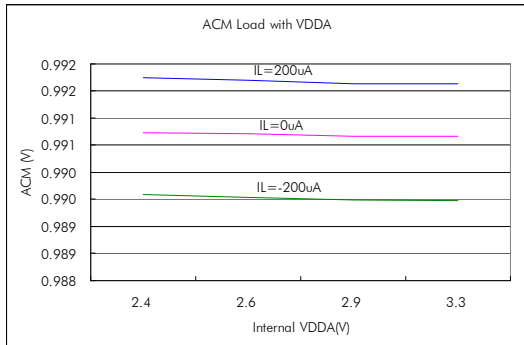

Figure 6.6-5 ACM Load vs. VDDA

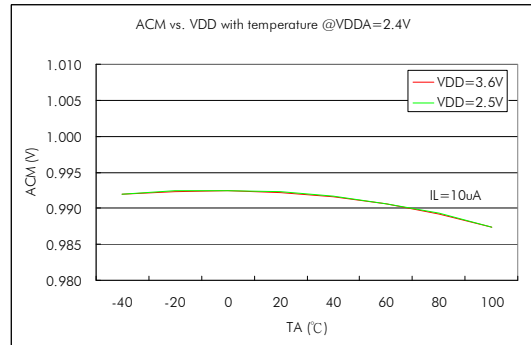

Figure 6.6-6 ACM vs. Temperature

6.7 LCD

$T_A = 25^\circ\text{C}$, $V_{DD} = 3.0\text{V}$, $C_{VLCD} = 4.7\mu\text{F}$, unless otherwise noted.

Sym.	Parameter	Test Conditions	Min.	Typ.	Max.	unit	
I_{LCD}	Operation supply current without output buffer.(all segment turn on)	LCDPR[0]=1	$V_{DD} = 2.2\text{V}$	20		uA	
			$V_{DD} = 3.0\text{V}$				
VLCD	Supply Voltage at VLCD pin	LCDPR[0]=0	2.2		3.6	V	
	Embedded Charge Pump output voltage at VLCD pin	$V_{DD} = 2.2\text{V}$, LCDPR[0]=1, $C_{VLCD} = 4.7\mu\text{F}$	VLCDX[1:0]=11b	2.295	2.55	2.805	V
			VLCDX[1:0]=10b	2.52	2.8	3.08	
			VLCDX[1:0]=01b	2.745	3.05	3.355	
VLCDX[1:0]=00b	2.97	3.3	3.63				
Z_{LCD}	Output impedance with LCD buffer	$f_{LCD} = 128\text{Hz}$, VLCD=3.05V		10		k Ω	

Curve Chart :

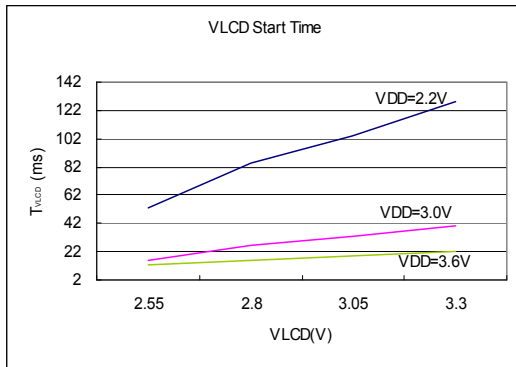

Figure 6.7-1 LCD start time

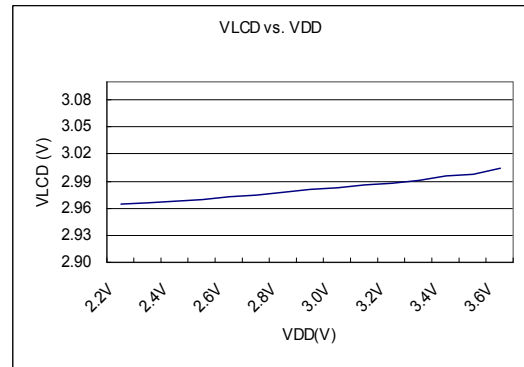

Figure 6.7-2 VLCD vs. VDD

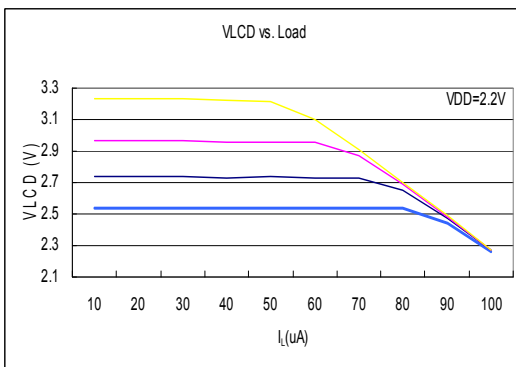

Figure 6.7-3 VLCD vs. I_L @VDD=2.2V

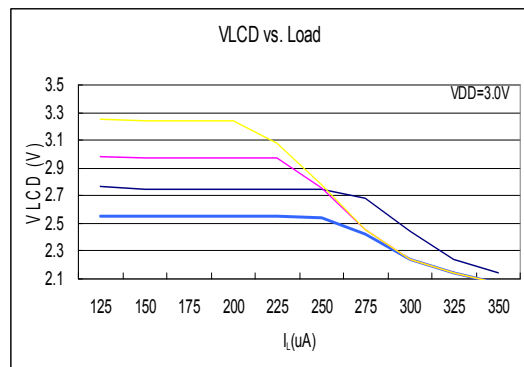

Figure 6.7-4 VLCD vs. I_L @VDD=3.0V

6.8 Low Noise OPAMP

$T_A = 25^\circ\text{C}$, $V_{DD} = 3.0\text{V}$, $V_{DDA} = 2.4\text{V}$, unless otherwise noted

Sym.	Parameter	Test Conditions		Min.	Typ.	Max.	unit
V_{LNOF}	Supply voltage at VDDA	ENVDDA[0]=0		2.4		3.6	V
I_{LNOF}	Operation supply current		OPM[1:0]=xxb		200		μA
V_{OS-OP}	Input offset voltage without chopper.		OPM[1:0]=1xb	-2		2	mV
	Input offset voltage with chopper		OPM[1:0]=0xb		20		μV
	Input offset voltage temperature drift.	OPM[1:0]=00b OPM[1:0]=10	$T_A = -40^\circ\text{C} \sim 85^\circ\text{C}$		0.1 2		$\mu\text{V}/^\circ\text{C}$
V_{OLR}	Unit gain load regulation	$V_O = 1.2\text{V}$, $V_{DDA} = 2.4\text{V}$		$I_L = +1\text{mA}$ $I_L = -1\text{mA}$		0.1	$\%V_O$
CMVR	Common-mode voltage input range		OPM[1:0]=xxb	0.1		$V_{DDA} - 1.1$	V
CMRR	Common-mode rejection ratio		OPM[1:0]=xxb		90		dB

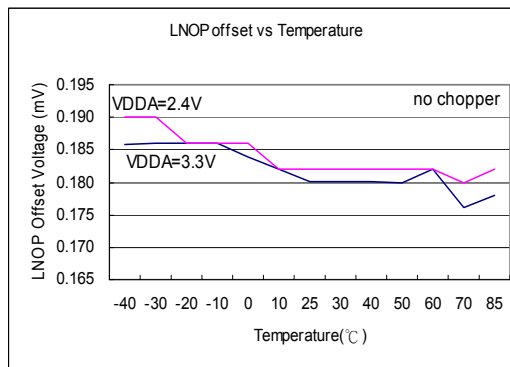

Figure 6.8-1 LNOP Offset Temperature

6.9 SD18, Power Supply and Recommended Operating Conditions

$T_A = 25^\circ\text{C}$, $V_{DD} = 3.0\text{V}$, $V_{DDA}=2.4\text{V}$, unless otherwise noted

Sym.	Parameter	Test Conditions		Min.	Typ.	Max.	unit
V_{SD18}	Supply Voltage at VDDA	ENVDDA[0]=0		2.4		3.6	V
f_{SD18}	Modulator sample frequency, ADC_CK			25	250	300	KHz
	Over Sample Ratio, OSR			256		32768	
I_{SD18}	Operation supply current without PGA	ENADC[0]=1	GAIN =4, ADC_CK=250KHz		120		μA

6.9.1 PGA, Power Supply and Recommended Operating Conditions

$T_A = 25^\circ\text{C}$, $V_{DD} = 3.0\text{V}$, $V_{DDA}=2.4\text{V}$, unless otherwise noted

Sym.	Parameter	Test Conditions		Min.	Typ.	Max.	unit
V_{PGA}	Supply Voltage at VDDA	ENVDDA[0]=0		2.4		3.6	V
I_{PGA}	Operation supply current	PGAGN[1:0]=<01>or<1x>			320		μA
G_{PGA}	Gain temperature drift	$T_A = -40^\circ\text{C} \sim 85^\circ\text{C}$	GAIN=2 ~ 8		5		ppm/ $^\circ\text{C}$

6.9.2 SD18, Performance II ($f_{SD18}=250\text{KHz}$)

$T_A = 25^\circ\text{C}$, $V_{DD} = 3.0\text{V}$, $V_{DDA}=2.9\text{V}$, $V_{VR}=1.0\text{V}$, GAIN=1 without PGA, unless otherwise noted

Sym.	Parameter	Test Conditions		Min.	Typ.	Max.	unit
INL	Integral Nonlinearity(INL)	$V_{DDA}=2.4\text{V}$, $V_{VR}=1.0\text{V}$, $\Delta\text{SI}=\pm 200\text{mV}$			± 0.003	± 0.01	%FSR
		$V_{DDA}=2.4\text{V}$, $V_{VR}=1.0\text{V}$, $\Delta\text{SI}=\pm 450\text{mV}$					
	No Missing Codes ³	ADC_CK=250KHz, OSR[2:0]=010b		23			Bits
G_{SD18}	Temperature drift Gain 1~x16		$T_A = -40^\circ\text{C} \sim 85^\circ\text{C}$		2		ppm/ $^\circ\text{C}$
E_{OS}	Offset error of Full Scale Rang input voltage range with Chopper without PGA	$\Delta\text{AI}=0\text{V}$ $\Delta\text{VR}=0.9\text{V}$	Gain=2			1	%FSR
	Offset error temperature drift with chopper without PGA	$\text{DCSET}[2:0]=\langle 000 \rangle$ $\ast\Delta\text{AI}$ is external short	GAIN=1		2		$\mu\text{V}/^\circ\text{C}$
			GAIN=2		1		
			GAIN=4		0.5		
			GAIN=16		0.15		
Offset temperature drift with chopper without Buffer		GAIN=128		0.02			
CM_{SD18}	Common-mode rejection	$V_{CM}=0.7\text{V}$ to 1.7V ,	$V_{SI}=0\text{V}$,		90		dB

HY11P35

Embedded 18-Bit $\Sigma\Delta$ ADC 8-Bit RISC-like Mixed Signal Microcontroller

		$V_{VR}=1.0V$, without PGA	GAIN=1		
		$V_{CM}=0.7V$ to $1.7V$, $V_{VR}=1.0V$, without PGA	$V_{SI}=0V$, GAIN=16	75	
PSRR	DC power supply rejection	$V_{DDA}=3.0V$, $\Delta V_{DDA}=\pm 100m$ $V, V_{VR}=1.0V$, $V_{SI}=1.2V, V_{SI}=1.2V$,	GAIN=1 PGA=off GAIN=16 PGA=8	75	dB

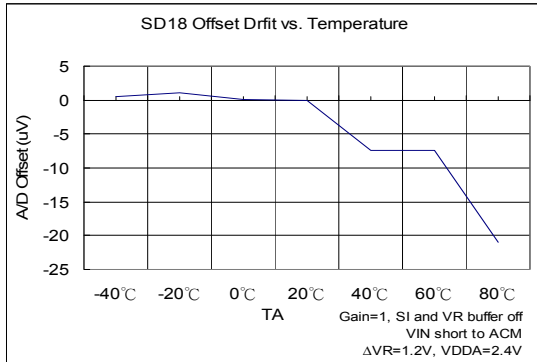

Figure 6.9-1(a) SD18 Offset Temperature drift

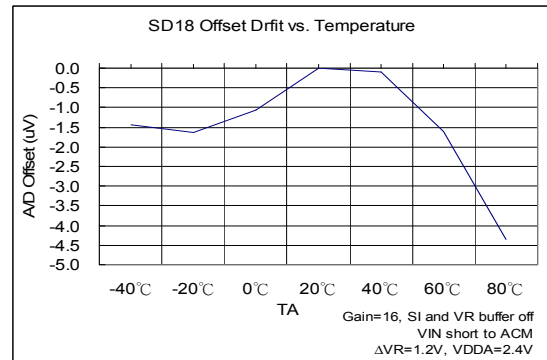

Figure 6.9-1(b) SD18 Offset Temperature drift

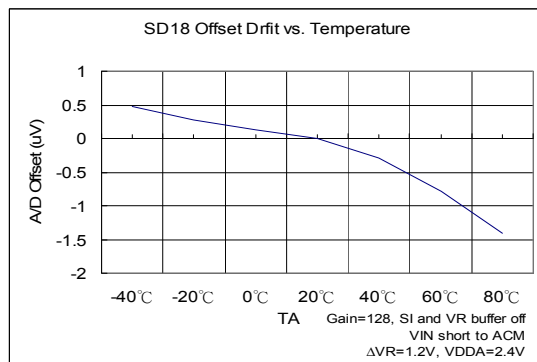

Figure 6.9-1(c) SD18 Offset Temperature Drift

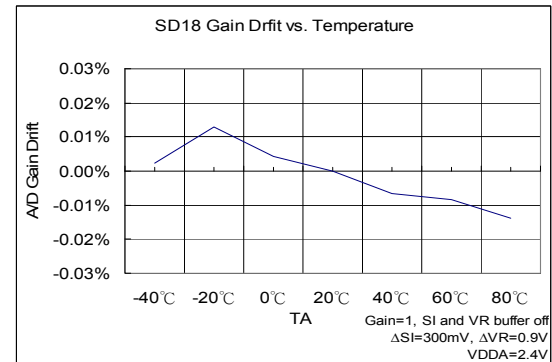

Figure 6.9-2(a) SD18 Gain Drift with Temperature

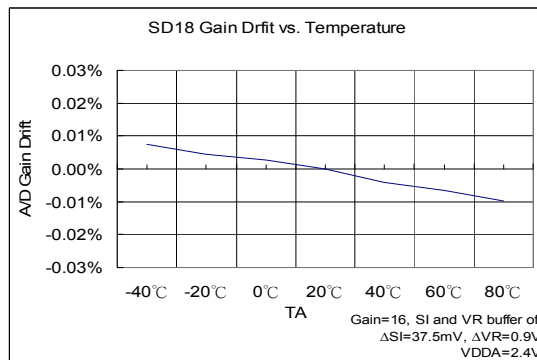

Figure 6.9-2(b) SD18 Gain Drift with Temperature

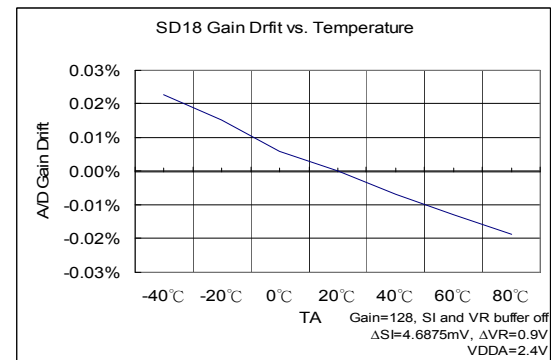

Figure 6.9-2(c) SD18 Gain Drift with Temperature

6.9.3 SD18, Temperature Sensor

$T_A = 25^\circ\text{C}$, $V_{DD} = 3.0\text{V}$, $V_{DDA} = 3.3\text{V}$, unless otherwise noted

Sym.	Parameter	Test Conditions	Min.	Typ.	Max.	unit
TC_S	Sensor temperature drift			178		$\mu\text{V}/^\circ\text{C}$
KT	Absolute Temperature Scale 0°K			-289		$^\circ\text{C}$
TC_{ERR}	One point calibrate error temperature	Calibration at 25°C of $-40^\circ\text{C} \sim 85^\circ\text{C}$		± 2		$^\circ\text{C}$

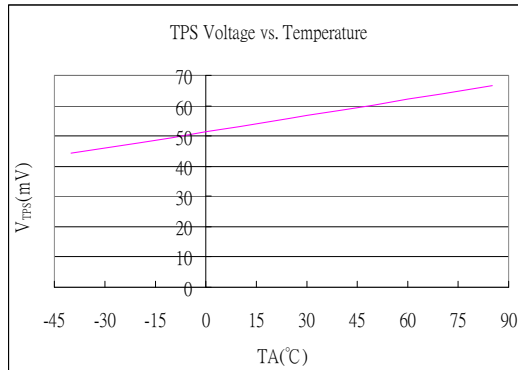

Figure 6.9-3 TPS output voltage vs. Temperature Drift

6.9.4 SD18 Noise Performance

$T_A = 25^\circ\text{C}$, $V_{DD} = 3.0\text{V}$, $V_{DDA}=2.4\text{V}$, unless otherwise noted

HY11P35 provides important input noise specification that aims at SD18. Table 6.9-4(a) and Table 6.9-4(b) lists out the relations of typical noise specification, Gain, Output rate, and maximum input voltage of single end. Test condition configuration and external input signal short, voltage reference: 1.2V and 1024 records were sampled.

ENOB(RMS) with OSR/GAIN at A/D Clock=250Khz, VDDA=2.4V, VREF=1.2V													
Max. Vin(mV) =0.9*VREF ⁽¹⁾	OSR				256	512	1024	2048	4096	8192	16384	32768	
	Output rate(HZ)				977	488	244	122	61	31	15	8	
	Gain	=	PGA	x	ADGN								
± 2400	0.25	=	1	x	0.25	16.3	17.4	17.9	18.5	19.0	19.5	20.0	20.4
± 2160	0.5	=	1	x	0.5	16.3	17.3	17.9	18.4	18.9	19.4	19.8	20.2
± 1080	1	=	1	x	1	16.2	17.2	17.8	18.3	18.8	19.3	19.7	20.1
± 540	2	=	1	x	2	16.1	17.1	17.6	18.2	18.7	19.2	19.6	20.0
± 270	4	=	1	x	4	16.0	16.9	17.5	18.0	18.5	18.9	19.4	19.8
± 135	8	=	1	x	8	15.9	16.6	17.2	17.7	18.2	18.7	19.2	19.6
± 68	16	=	1	x	16	15.6	16.3	16.8	17.3	17.7	18.3	18.8	19.3
± 34	32	=	2	x	16	14.8	15.3	15.9	16.4	16.9	17.4	17.8	18.3
± 17	64	=	4	x	16	14.5	15.0	15.5	16.0	16.5	17.0	17.5	18.0
± 8	128	=	8	x	16	14.0	14.6	15.1	15.6	16.0	16.6	17.0	17.5

(1) Max.Vin (mV) is the max. input voltage of single end to ground (VSS).

Table 6.9-4(a) SD18 ENOB Table

RMS Noise(uV) with OSR/GAIN at A/D Clock=250Khz, VDDA=2.4V, VREF=1.2V													
Max. Vin(mV) =0.9*VREF	OSR				256	512	1024	2048	4096	8192	16384	32768	
	Output rate(HZ)				977	488	244	122	61	31	15	8	
	Gain	=	PGA	x	ADGN								
± 2400	0.25	=	1	x	0.25	121.08	57.40	38.74	26.66	18.39	13.21	9.49	6.98
± 2160	0.5	=	1	x	0.5	61.63	29.23	19.21	13.51	9.78	7.02	5.12	3.91
± 1080	1	=	1	x	1	32.21	15.70	10.25	7.31	5.19	3.77	2.80	2.13
± 540	2	=	1	x	2	16.59	8.54	5.91	4.06	2.86	2.06	1.48	1.12
± 270	4	=	1	x	4	9.00	4.84	3.33	2.37	1.67	1.19	0.87	0.65
± 135	8	=	1	x	8	5.04	2.97	2.02	1.44	1.01	0.73	0.51	0.39
± 68	16	=	1	x	16	3.03	1.84	1.29	0.92	0.70	0.46	0.33	0.24
± 34	32	=	2	x	16	2.61	1.81	1.27	0.89	0.62	0.45	0.32	0.23
± 17	64	=	4	x	16	1.66	1.13	0.80	0.56	0.41	0.29	0.20	0.14
± 8	128	=	8	x	16	1.13	0.77	0.55	0.38	0.28	0.19	0.14	0.10

Table 6.9-4(b) SD18 RMS Noise Table

The RMS noise are referred to the input. The Effective Number of Bits (ENOB (RMS Bit)) is defined as:

$$\text{ENOB(RMS)} = \frac{\ln\left(\frac{\text{FSR}}{\text{RMS Noise}}\right)}{\ln(2)}$$

$$\text{RMS Noise} = \frac{\left(2 \times \text{VREF} \times \sqrt{\sum_{k=1}^{1024} (\text{ADO}[k] - \text{Average})^2}\right)}{2^{23}}$$

Where FSR (Full - Scale Range) = $2 \times \text{VREF}/\text{Gain}$.

$$\text{Average} = \frac{\sum_{k=1}^{1024} (\text{ADO}[k])}{1024}$$

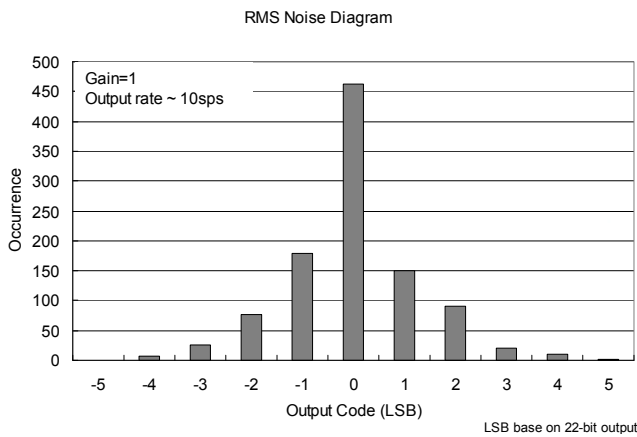

Figure 6.9-4(a) RMS Noise Diagram

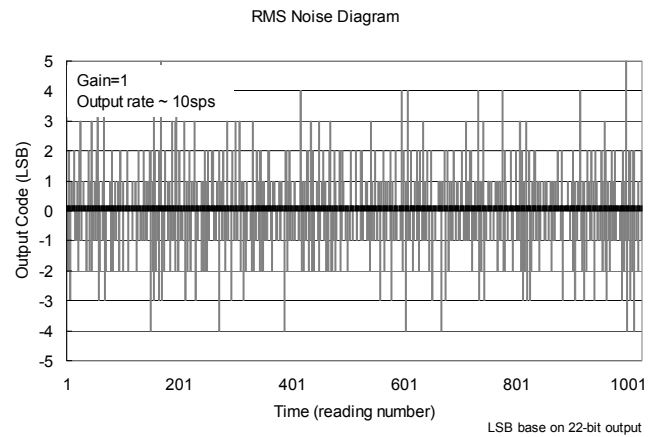

Figure 6.9-4(b) Output Code Diagram

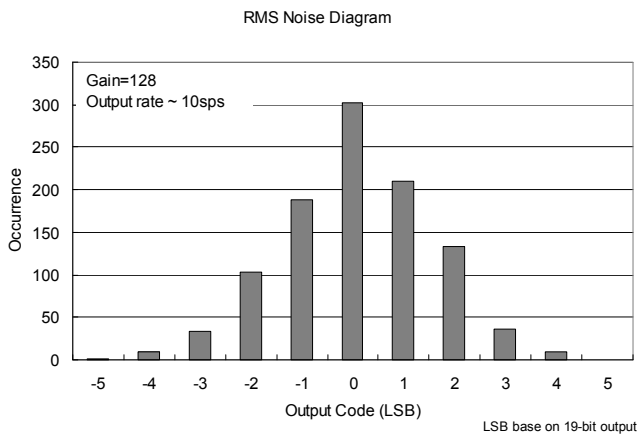

Figure 6.9-4(c) RMS Noise Diagram

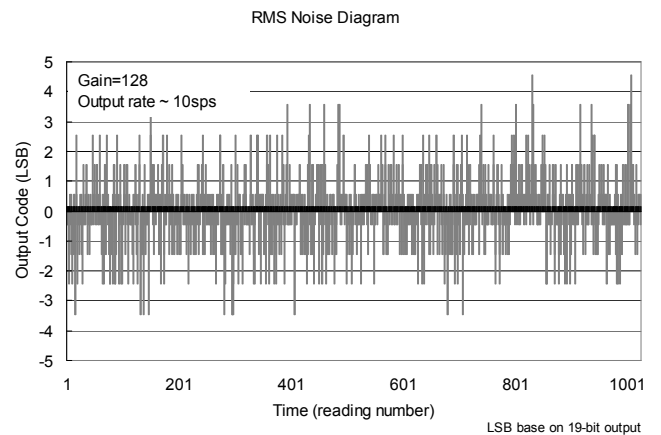

Figure 6.9-4(d) Output Code Diagram

6.10 Built-in EPROM (BIE)

$T_A = 25^\circ\text{C}$, $V_{DD} = 3.0\text{V}$, unless otherwise noted

Sym.	Parameter	Test Conditions	Min.	Typ.	Max.	unit
V_{BIE}	Supply Voltage			6.0	6.5	V
I_{BIE}	Operation supply current			5		mA
V_{SS}	Supply Voltage			0		V

HY11P35

Embedded 18-Bit ΣΔADC
8-Bit RISC-like Mixed Signal Microcontroller

7. Ordering Information

Device No. ¹	Package Type	Pins	Package Drawing		Code ²	Shipment Packing Type	Unit Q'ty	Material Composition	MSL ³
HY11P35-D000	Die	-	D	000	000	-	100	Green ⁴	-
HY11P35-L100	LQFP	100	L	100	000	Tray	90	Green ⁴	MSL-3

¹ **Device No.:** Model No. – Package Type Description – Code (Blank Code/ Standard/ Customized Programming Code)

Ex: Your customized programming code is 008 and you require die shipment.

The device No. will be HY11P35-D000-008.

Ex: You request blank code in die package.

The device No. will be HY11P35-D000.

Ex: You request blank code in LQFP 100 package.

The device No. will be HY11P35-L100.

And please clearly indicate the shipment packing type when placing orders.

Ex: Your customized programming code is 009 and you require products in LQFP 100 package.

The device No. will be HY11P35-L100-009.

And please clearly indicate the shipment packing type when placing orders.

² **Code:**

“001”~ “999” is standard or customized programming code. Blank code does not have these numbers.

³ **MSL:**

The Moisture Sensitivity Level ranking conforms to IPC/JEDEC J-STD-020 industry standard categorization. The products are processed, packed, transported and used with reference to IPC/JEDEC J-STD-033.

⁴ **Green (RoHS & no Cl/Br):**

HYCON products are Green products that compliant with RoHS directive and are Halogen free (Br/Cl<0.1%)

HY11P35

Embedded 18-Bit $\Sigma\Delta$ ADC
8-Bit RISC-like Mixed Signal Microcontroller

8. Package Information

8.1 LQFP100(L100)

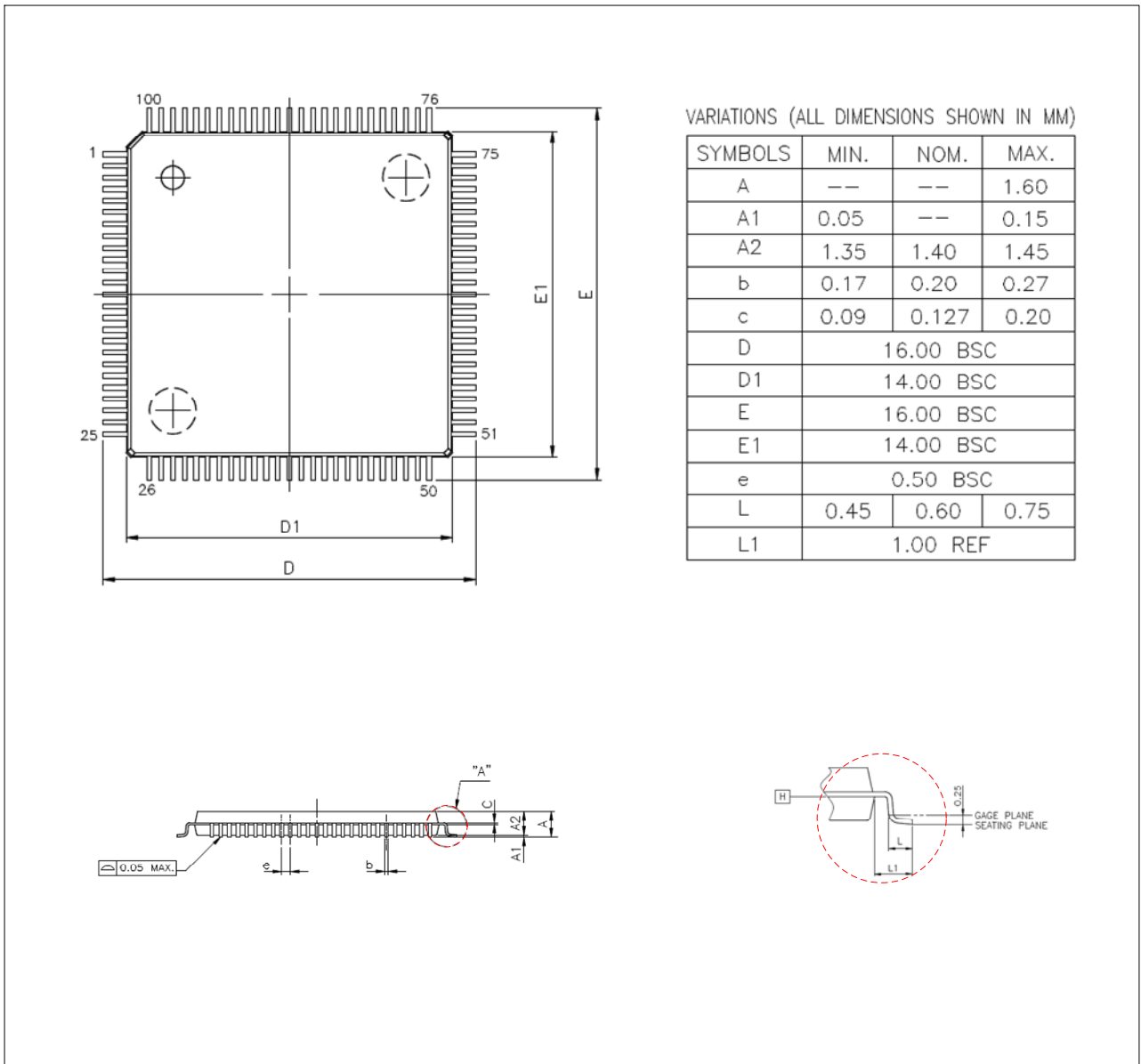

JEDEC MS-026 compliant

9. Revision Record

Major differences are stated thereafter:

Version	Page	Revision Summary
V03	ALL	First Edition
V06	5	Features revision
	12	Revise 4.2 Development Tool Related Operating Instruction serial numbers
	14	Add in 4.3 SD18 Network
	17	Chapter 6 Electrical Characteristics revision
	24	Chapter 6.6 Power System revision
	31~32	Add in 6.9.4 SD18 Noise Performance
	33	Chapter 7 Ordering information revision
V07	14	Add in 4.4 Low Noise OPAMP Network
V08	13	Revise SD18 Network
	All	Update INBUF/VRBUF description