



HY11P13
Datasheet
8-Bit RISC-like Mixed Signal Microcontroller
Embedded 4x20 LCD Driver
Low Noise Amplifier
18-Bit $\Sigma\Delta$ ADC

Table of Contents

1. FEATURES	5
2. PIN DEFINITION	6
2.1. 64PIN Diagram LQFP64	6
2.2. LQFP64 Pinout I/O Description.....	7
3. APPLICATION CIRCUIT	10
3.1. Bridge Sensor I	10
3.2. Bridge Sensor II	11
3.3. Bridge Sensor (Pressure Sensor).....	12
3.4. IR Sensor	13
3.5. 4-20mA Current Panel Meter (Two-wire type)	14
4. FUNCTION OUTLINE	15
4.1. Internal Block Diagram.....	15
4.2. Related Description and Supporting Documents.....	15
4.3. SD18 Network	16
4.4. Low Noise OPAMP Network	17
5. REGISTER LIST	18
6. ELECTRICAL CHARACTERISTICS	20
6.1. Recommended operating conditions	20
6.2. Internal RC Oscillator	21
6.3. Supply current into VDD excluding peripherals current.....	22
6.4. Port1~2.....	24
6.5. Reset (Brownout, External RST pin, Low Voltage Detect).....	25

HY11P13

Embedded 18-Bit $\Sigma\Delta$ ADC

8-Bit RISC-like Mixed Signal Microcontroller



6.6.	Power System	27
6.7.	LCD	29
6.8.	Low Noise OPAMP	30
6.9.	SD18, Power Supply and Recommended Operating Conditions	31
7.	ORDERING INFORMATION	37
8.	PACKAGE INFORMATION.....	38
8.1.	LQFP64 (L064)	38
8.2.	LQFP64(LS64)	39
9.	REVISION RECORD.....	40

Attention :

1. HYCON Technology Corp. reserves the right to change the content of this datasheet without further notice. For most up-to-date information, please constantly visit our website:
<http://www.hycontek.com> .
2. HYCON Technology Corp. is not responsible for problems caused by figures or application circuits narrated herein whose related industrial properties belong to third parties.
3. Specifications of any HYCON Technology Corp. products detailed or contained herein stipulate the performance, characteristics, and functions of the specified products in the independent state. We does not guarantee of the performance, characteristics, and functions of the specified products as placed in the customer's products or equipment. Constant and sufficient verification and evaluation is highly advised.
4. Please note the operating conditions of input voltage, output voltage and load current and ensure the IC internal power consumption does not exceed that of package tolerance. HYCON Technology Corp. assumes no responsibility for equipment failures that resulted from using products at values that exceed, even momentarily, rated values listed in products specifications of HYCON products specified herein.
5. Notwithstanding this product has built-in ESD protection circuit, please do not exert excessive static electricity to protection circuit.
6. Products specified or contained herein cannot be employed in applications which require extremely high levels of reliability, such as device or equipment affecting the human body, health/medical equipments, security systems, or any apparatus installed in aircrafts and other vehicles.
7. Despite the fact that HYCON Technology Corp. endeavors to enhance product quality as well as reliability in every possible way, failure or malfunction of semiconductor products may happen. Hence, users are strongly recommended to comply with safety design including redundancy and fire-precaution equipments to prevent any accidents and fires that may follow.
8. Use of the information described herein for other purposes and/or reproduction or copying without the permission of HYCON Technology Corp. is strictly prohibited.

1. Features

- 8-bit RISC, 66 instructions included.
- Operating voltage range: 2.2V to 3.6V, operation temperature range: -40°C~85°C.
- External Crystal Oscillator and Internal High Precision RC Oscillator, 6 CPU clock rates enable users to have the most power-saving plan.
 - Active Mode 300uA@2MHz
 - Standby Mode 3uA@32KHz
 - Sleep Mode 1uA
- 4K Word OTP (One Time Programmable) Type program memory, 256 Byte Data Memory.
- Brownout detector and Watch dog Timer, prevents CPU from Crash.
- 18-bit fully differential input Sigma-Delta Analog-to-Digital Converter (A/D)
 - Build-in PGA (Programmable Gain Amplifier) 1/4x · 1/2x · 1x. ... 128x, 10 input signal gain selection.
 - Build-in Input zero adjustment can increase measurement range according to different application.
 - Built-in high impedance input buffer (Not suitable for 32x or upwards input gain).
 - Built-in absolute temperature sensor
- Ultra-Low Input Noise (<1uVpp) OP provides high output impedance, small signal amplification and low current voltage transformation.
- 1.0 V internal analog circuit common ground that equips with Push-Pull drive ability to provide sensor driving voltage.
- LVD low voltage detection function has 14 steps of voltage detection configuration and external input voltage detection function.
- VDDA can select 4 different output voltage that equips with 10mA low dropout regulator function.
- 4x20 LCD driver
 - Static · 1/2 · 1/3 · 1/4 Duty and 1/3 Bias programmable option.
 - Built-in Charge Pump regulated circuit, providing 4 LCD Bias voltage.
- 8-bit Timer A
- 16-bit Timer B module has Capture/ Compare function.
- 8-bit Timer C module can generate PWM/PFD waveform.
- Serial communication SPI module
- Support 6 stack level

HY11P13

Embedded 18-Bit $\Sigma\Delta$ ADC

8-Bit RISC-like Mixed Signal Microcontroller

2. Pin Definition

2.1. 64PIN Diagram LQFP64

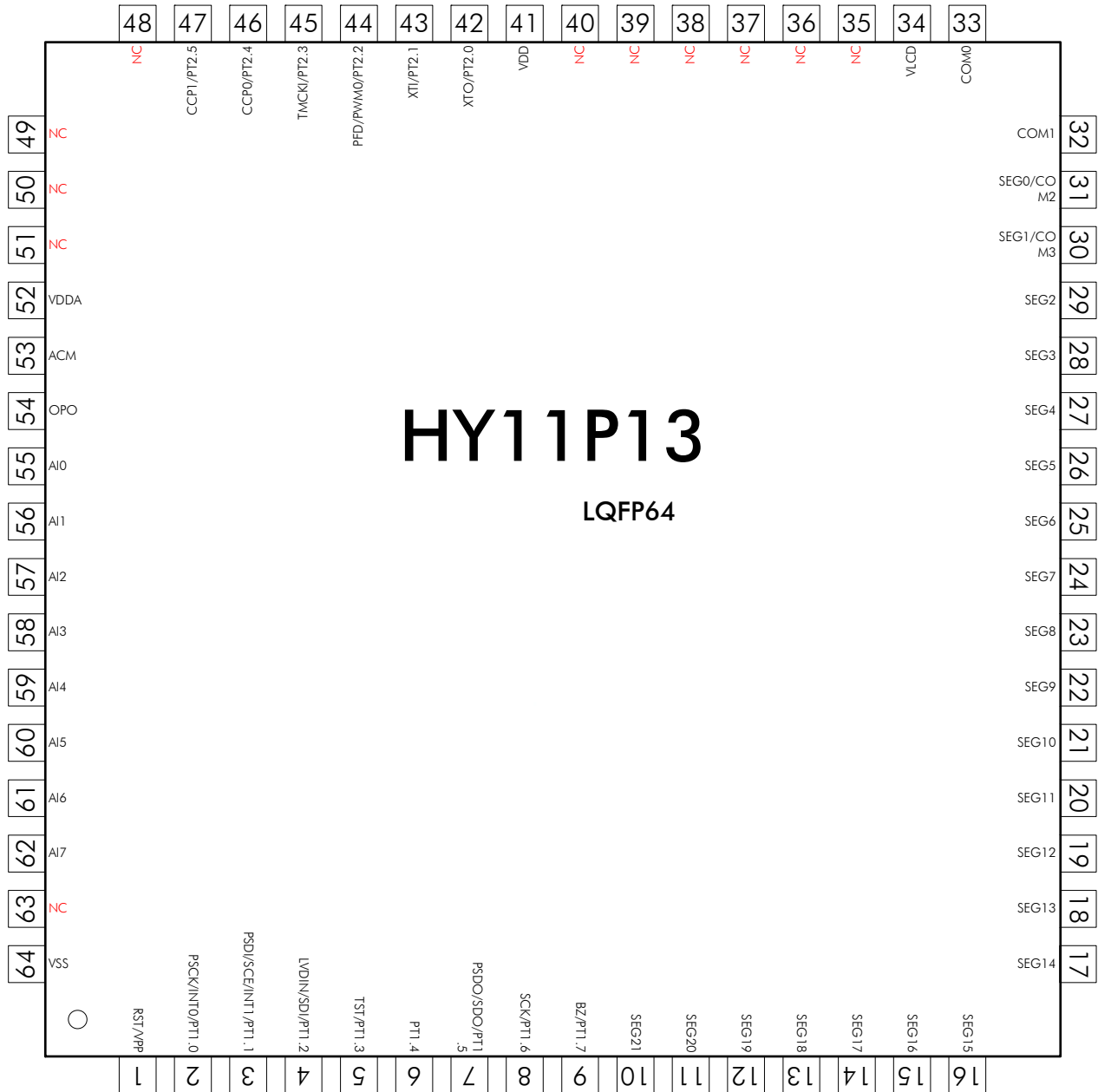

Figure 2-1 HY11P13 LQFP64 Pin Diagram

Note 1 : VPP and RST use the same pin. Input voltage cannot exceed 5.8V when not programming EPROM.

Note 2 : TST and PT1.3 use the same pin. Input voltage cannot exceed Vdd+0.3V while operating.

Note 3 : If PT1.3 is not configured as external button pin, the anti-interference ability will be enhanced.

2.2. LQFP64 Pinout I/O Description

"I/O" input/output, "I" input, "O" output, "S" Smith Trigger, "C" CMOS features compatible input/output, "P" power supply, "A" analog channel

NO.	Pin Name	Pin		Description
		Characteristic		
		Pin Type	Buffer Type	
1	RST	I	S	Reset IC
	VPP	P	P	EPROM programming voltage input
2	PT1.0	I	S	Digital input
	INT0	I	S	Interrupt input INT0
	PSCK	I	S	OTP programming interface SCK
3	PT1.1	I	S	Digital input
	INT1	I	S	Interrupt input INT 1
	PSDI	I	S	OTP programming interface SDI
	SCE	I	S	SPI communication interface SCE
4	PT1.2	I	S	Digital input
	SDI	I/O	S	SPI communication interface SDI
	LVDIN	A	A	LVD external signal input interface
5	PT1.3	I	S	Digital input
	TST	I	S	Test Mode input pin (invalid)
6	PT1.4	I/O	S	Digital output
7	PT1.5	I/O	S	Digital I/O
	PSDO	O	C	OTP programming interface SDO
	SDO	I/O	S	SPI communication interface SDO
8	PT1.6	I/O	S	Digital input/output
	SCK	I/O	S	SPI communication interface SCK
9	PT1.7	I/O	S	Digital I/O
	BZ	O	C	Buzzer output
10	SEG21	O	A	Segment output for LCD
11	SEG20	O	A	Segment output for LCD
12	SEG19	O	A	Segment output for LCD

HY11P13

Embedded 18-Bit Σ ADC

8-Bit RISC-like Mixed Signal Microcontroller

13	SEG18	O	A	Segment output for LCD	
14	SEG17	O	A	Segment output for LCD	
15	SEG16	O	A	Segment output for LCD	
16	SEG15	O	A	Segment output for LCD	
17	SEG14	O	A	Segment output for LCD	
18	SEG13	O	A	Segment output for LCD	
19	SEG12	O	A	Segment output for LCD	
20	SEG11	O	A	Segment output for LCD	
21	SEG10	O	A	Segment output for LCD	
22	SEG9	O	A	Segment output for LCD	
23	SEG8	O	A	Segment output for LCD	
24	SEG7	O	A	Segment output for LCD	
25	SEG6	O	A	Segment output for LCD	
26	SEG5	O	A	Segment output for LCD	
27	SEG4	O	A	Segment output for LCD	
28	SEG3	O	A	Segment output for LCD	
29	SEG2	O	A	Segment output for LCD	
30	COM3/SEG1	O	A	COM/segment output for LDO	
31	COM2/SEG0	O	A	COM/segment output for LDO	
32	COM1	O	A	COM output for LDO	
33	COM0	O	A	COM output for LDO	
34	VLCD	P	P	Power supply for LDO	
35	NC	-	-	Unused	
36	NC	-	-	Unused	
37	NC	-	-	Unused	
38	NC	-	-	Unused	
39	NC	-	-	Unused	
40	NC	-	-	Unused	
41	VDD	P	P	Power supply for IC operation	
42	PT2.0/XTO	PT2.0	I/O	S	Digital I/O
		XTO	A	A	External oscillator output
43	PT2.1/XTI	PT2.1	I/O	S	Digital I/O
		XTI	A	A	External oscillator input
44	PT2.2/PWM0/PFD	PT2.2	I/O	C	Digital I/O
		PWM0	O	C	PWM output

	PFD	O	C	PFD output
45	PT2.3/TMCKI			
	PT2.3 TMCKI	I/O I	S S	Digital I/O TIMERC clock source input
46	PT2.4/CCP0			
	PT2.4 CCP0	I/O I	S S	Digital I/O CCP mode signal interface
47	PT2.5/CCP1			
	PT2.5 CCP1	I/O I	S S	Digital I/O CCP mode signal interface
48	NC	-	-	Unused
49	NC	-	-	Unused
50	NC	-	-	Unused
51	NC	-	-	Unused
52	VDDA	P	P	Regulator output Analog circuit voltage source
53	ACM	P	P	Internal analog circuit common ground pin
54	OPO	A	A	OP output
55	AI0	A	A	Analog channel pin
56	AI1	A	A	Analog channel pin
57	AI2	A	A	Analog channel pin
58	AI3	A	A	Analog channel pin
59	AI4	A	A	Analog channel pin
60	AI5	A	A	Analog channel pin
61	AI6	A	A	Analog channel pin
62	AI7	A	A	Analog channel pin
63	NC	-	-	Unused
64	VSS	P	P	Grounding pin for IC operation voltage

Table 2-1 Pin Definition and Function Description

HY11P13

Embedded 18-Bit $\Sigma\Delta$ ADC

8-Bit RISC-like Mixed Signal Microcontroller

3. Application Circuit

3.1. Bridge Sensor I

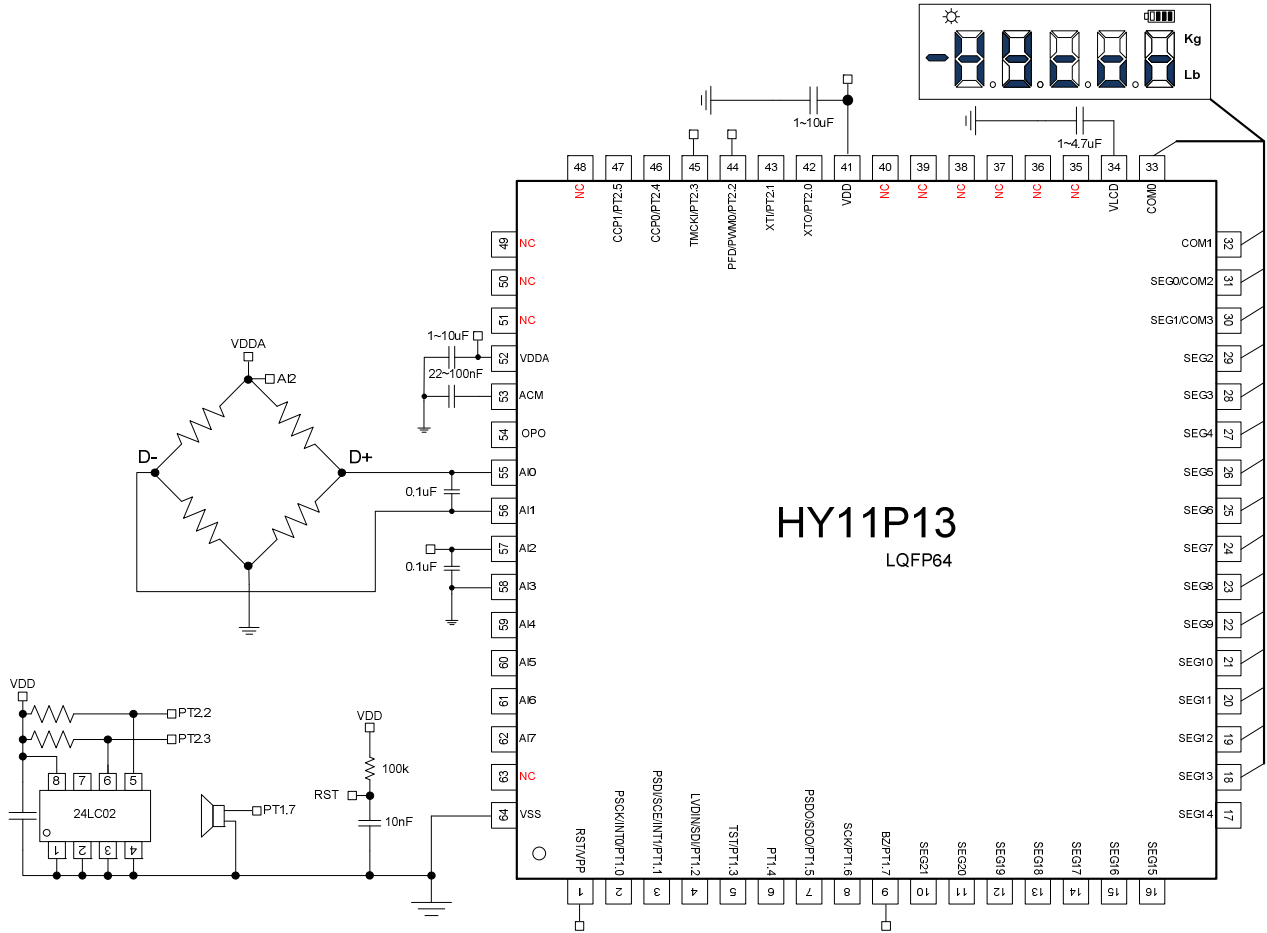

Figure 3-1 Bridge Sensor Application Circuit

Note 1 : DCSET[2:0] can conduct bias adjustment of Load Cell zero point voltage address

HY11P13

Embedded 18-Bit $\Sigma\Delta$ ADC

8-Bit RISC-like Mixed Signal Microcontroller

3.2. Bridge Sensor II

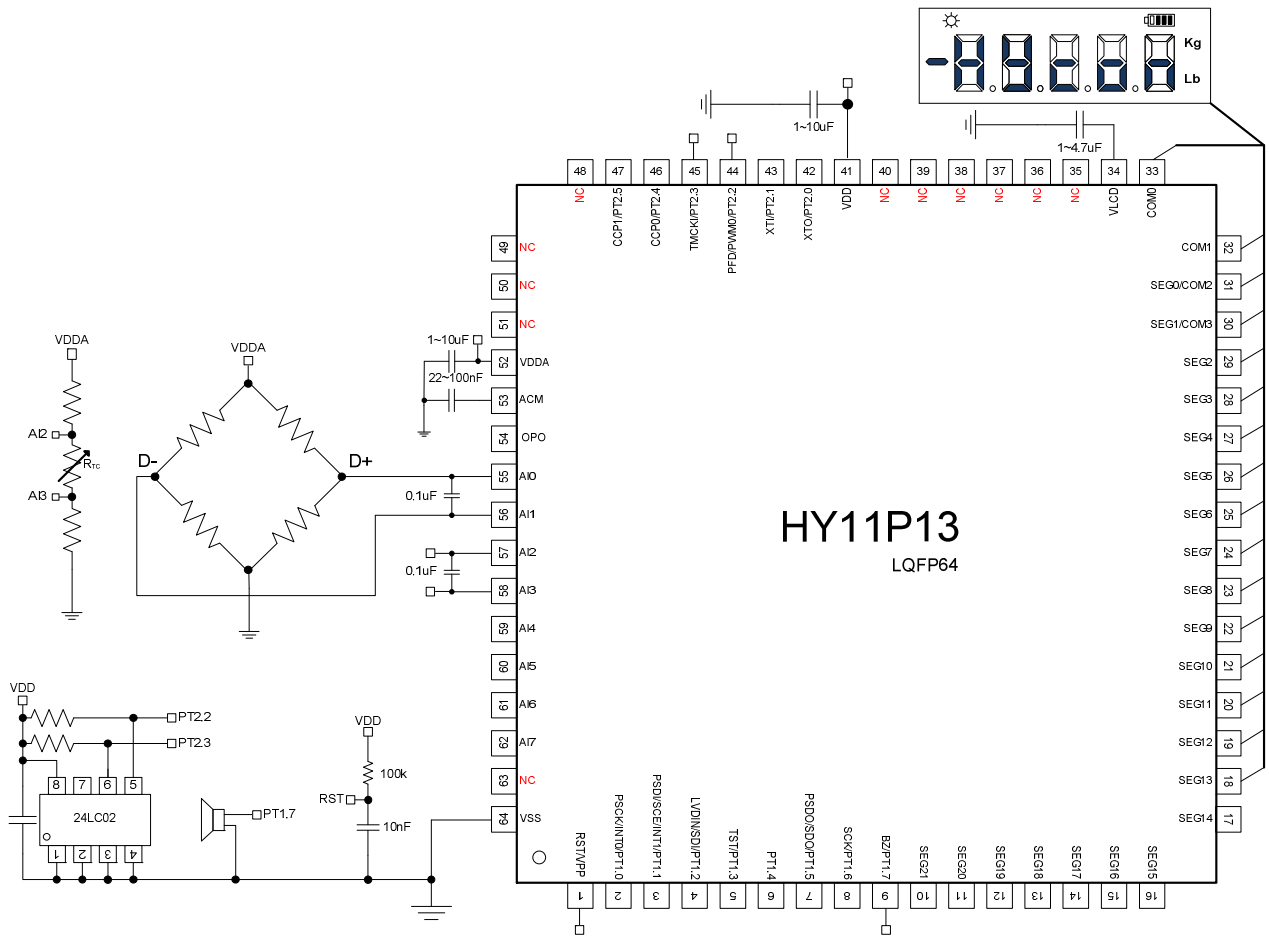

Figure 3-2 Application Circuit of Temperature Compensation Bridge Sensor

Note 1 : Using temperature compensation resistor NTC basic circuit

Note 2 : DCSET[2:0] can conduct bias adjustment of Load Cell zero point voltage address

HY11P13

Embedded 18-Bit $\Sigma\Delta$ ADC

8-Bit RISC-like Mixed Signal Microcontroller

3.3. Bridge Sensor (Pressure Sensor)

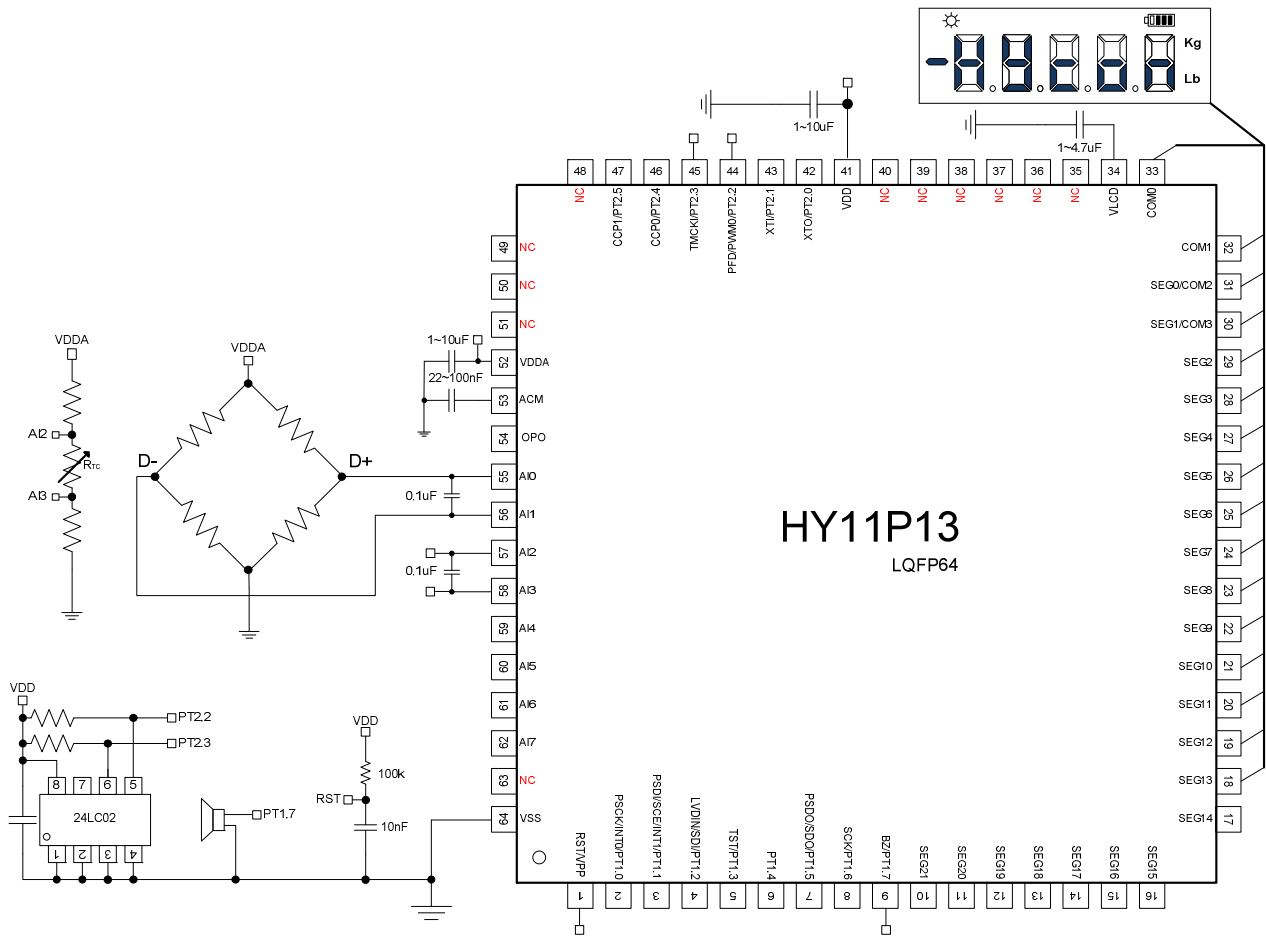

Figure 3-3 Temperature Compensative Bridge Sensor Application Circuit (wo/ internal PGA amplification)

Note 1 : Using temperature compensation resistor NTC basic circuit

Note 2 : Pressure sensor zero point voltage address can be configured through DCSET[2:0] bias adjustment.

HY11P13

Embedded 18-Bit $\Sigma\Delta$ ADC

8-Bit RISC-like Mixed Signal Microcontroller

3.4. IR Sensor

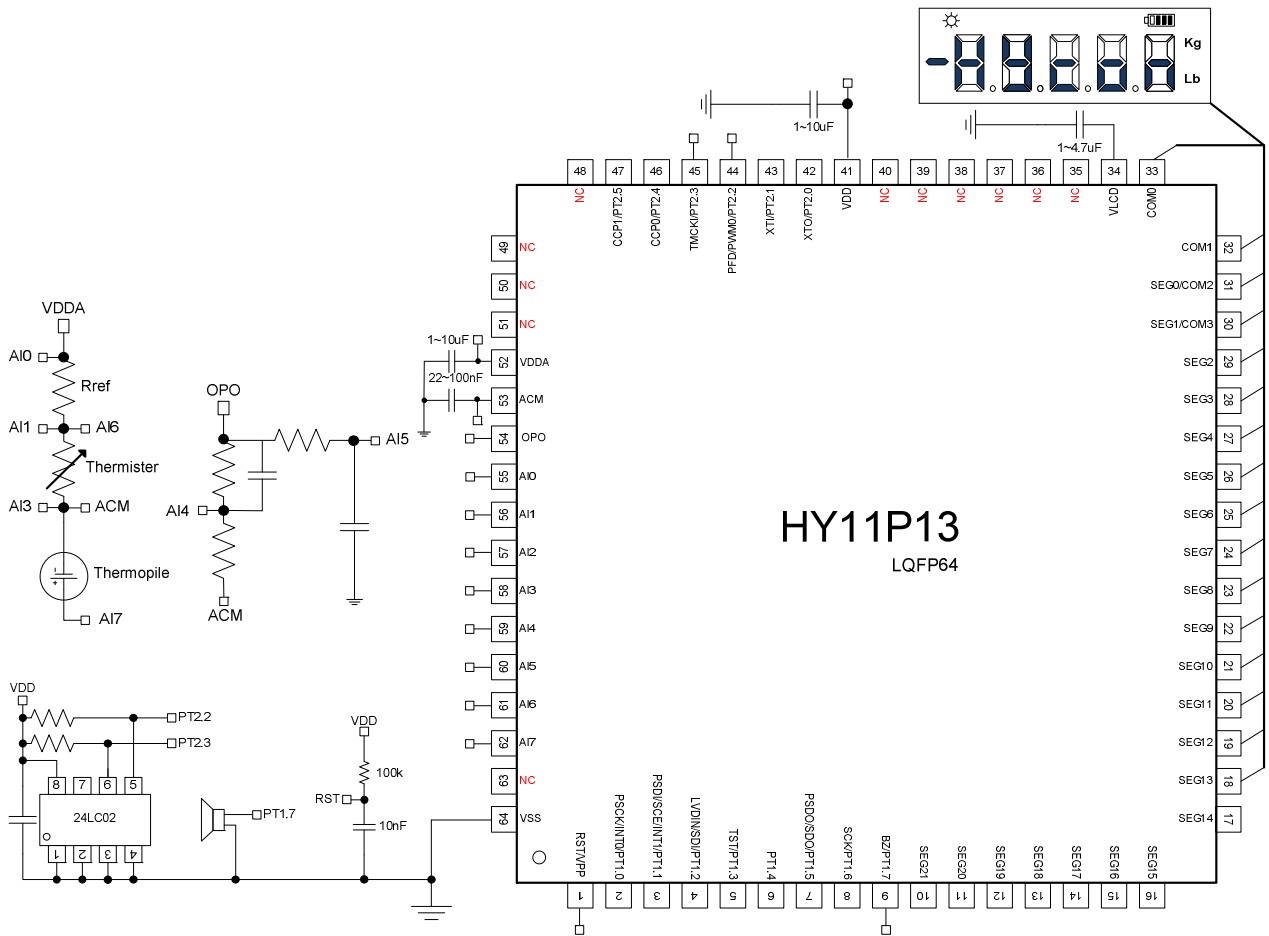

Figure 3-4 IR Sensor Application Circuit

HY11P13

Embedded 18-Bit $\Sigma\Delta$ ADC

8-Bit RISC-like Mixed Signal Microcontroller

3.5. 4-20mA Current Panel Meter (Two-wire Type)

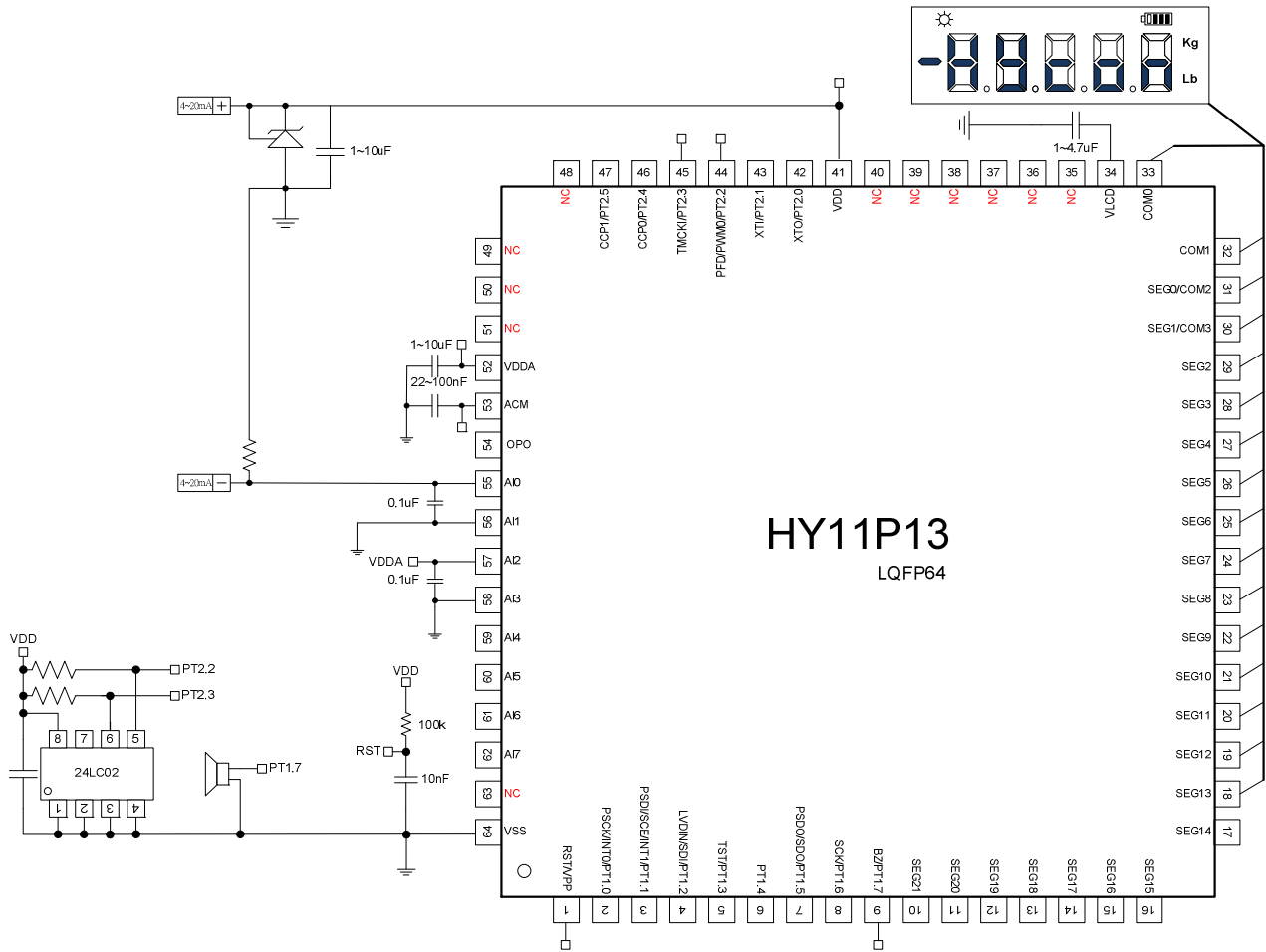
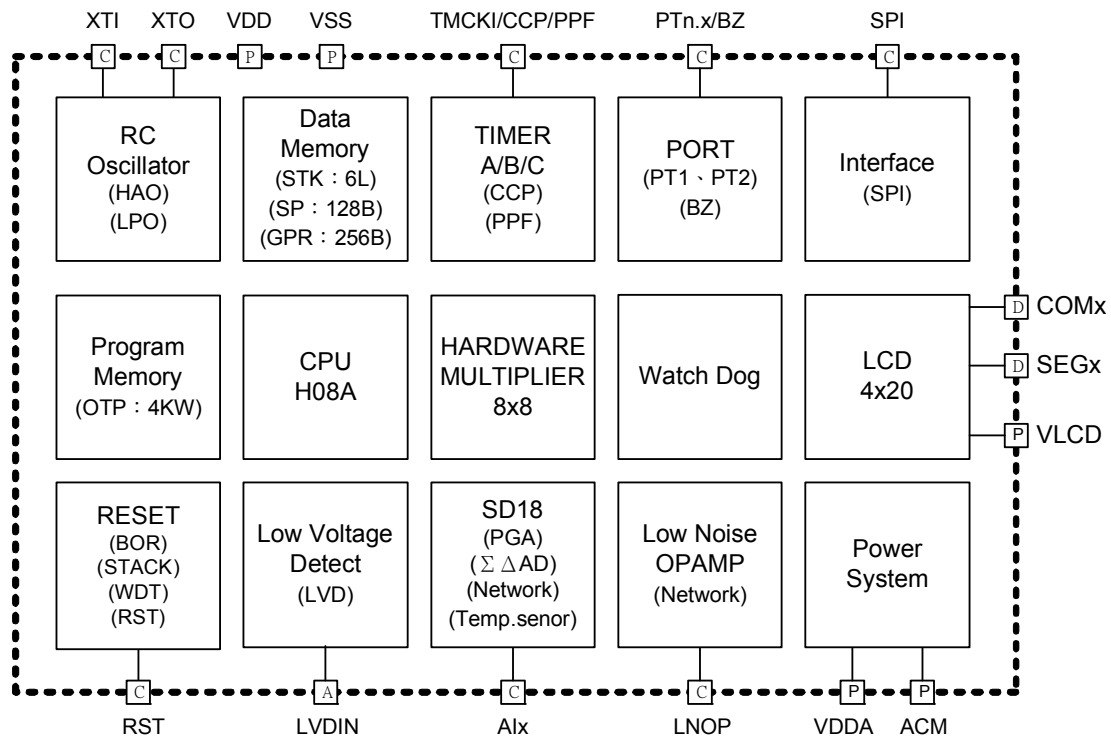

Figure 3-5 4-20mA Panel Meter that Unneeded to Connect External Power Supply

4. Function Outline

4.1. Internal Block Diagram



P Power Pad
 D Digital Pad
 A Analog Pad
 C Common I/O Pad

Figure 4-1 HY11P13 Internal Block Diagram

4.2. Related Description and Supporting Documents

IC Function Related Operating Instruction

- DS-HY11P13-Vxx HY11P13 Data Sheet
- UG-HY11S14-Vxx HY11P Series Users' Manual
- APD-CORE002-Vxx H08A Instruction Description

Development Tool Related Operating Instruction

- APD-HYIDE006-Vxx HY11xxx Series Development Tool Software Instruction Manual
- APD-HYIDE005-Vxx HY11xxx Series Development Tool Hardware Instruction Manual
- APD-OTP001-Vxx OTP Products Programming Pin Manual

Product Production Related Operating Instruction

- APD-HYIDE004-Vxx HY1xxxx Series Production Line Specialized Programmer Manual
- BDI-HY11P13-Vxx HY11P13 Individual Product Die Bonding Information

4.3. SD18 Network

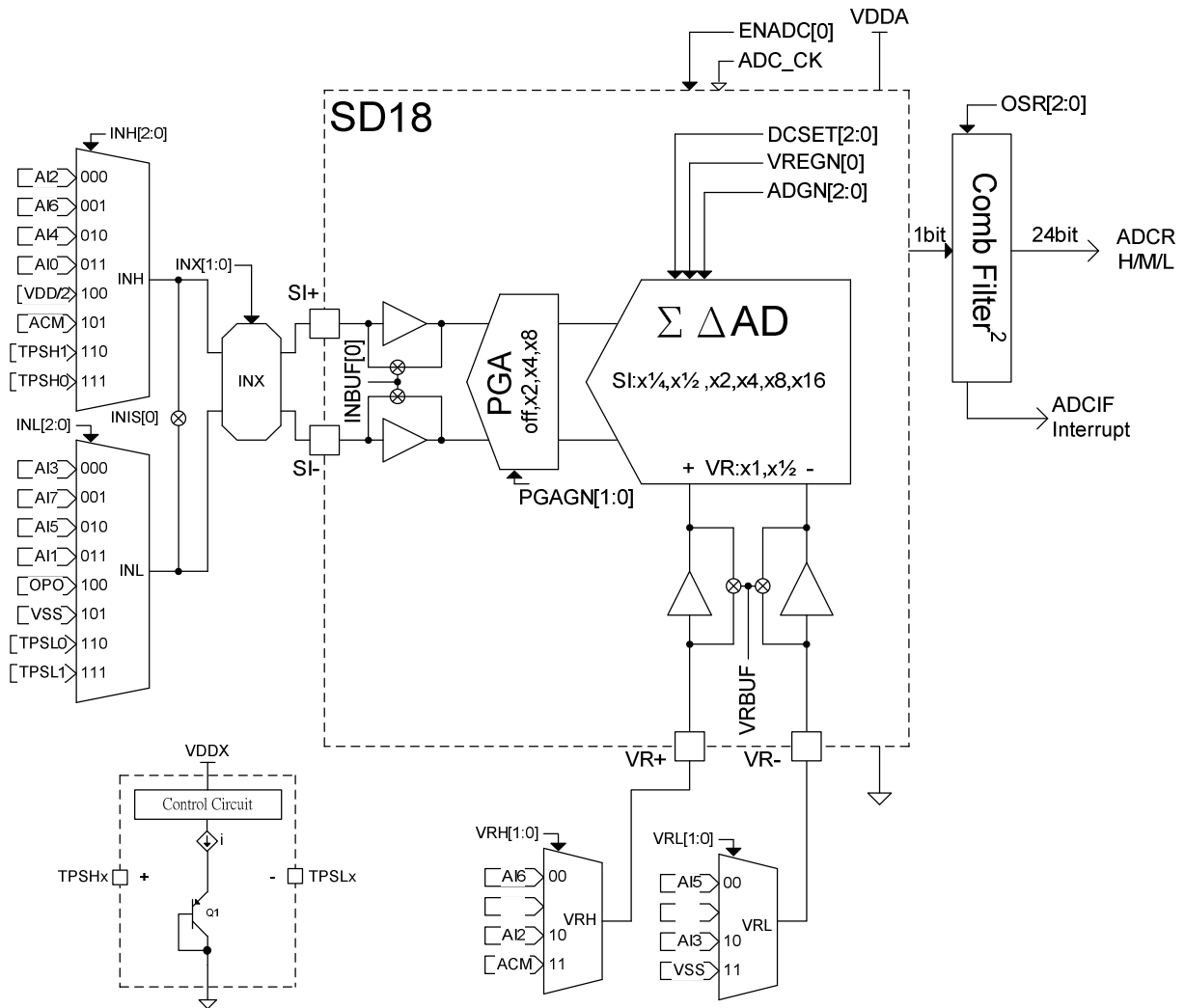

Figure 4-2 SD18 Network

4.4. Low Noise OPAMP Network

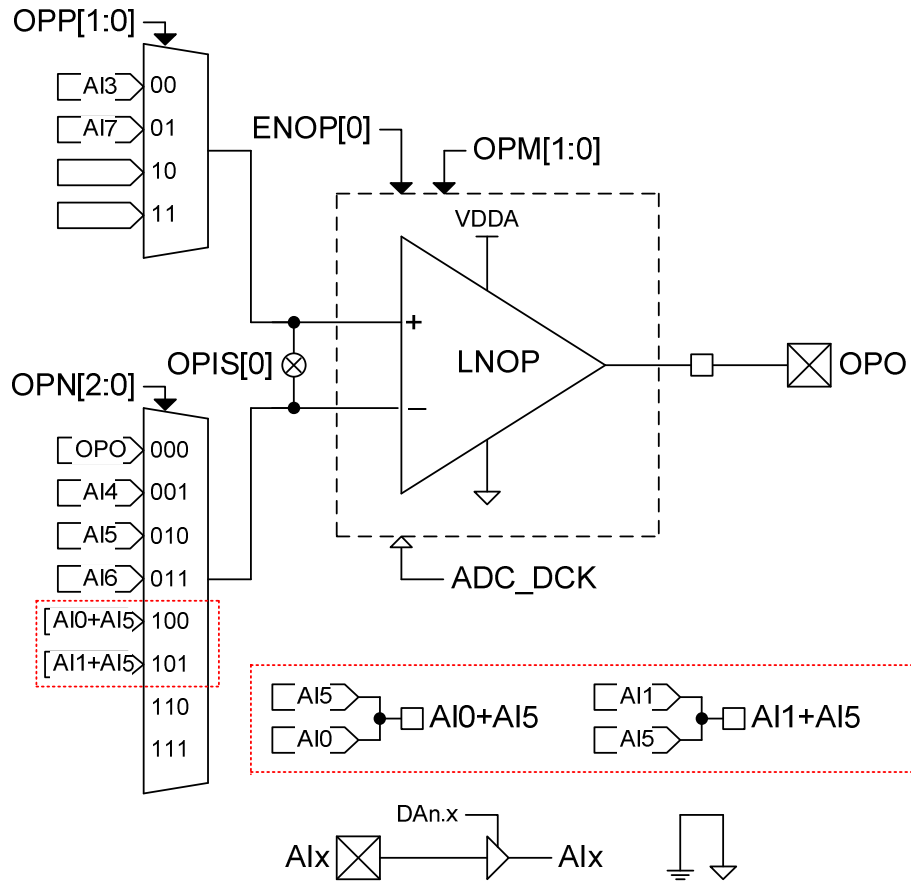

Figure 4-3 Low Noise OPAMP Network

5. Register List

“.”no use,“*”read/write,“w”write,“r”read,“r0”only read 0,“r1”only read 1,“w0”only write 0,“w1”only write 1 “.”unimplemented bit,“x”unknown,“u”unchanged,“d”depends on condition														
Address	File Name	Bit7	Bit6	Bit5	Bit4	Bit3	Bit2	Bit1	Bit0	A-RESET	i-RESET	R/W		
00H	INDF0	Contents of FSR0 to address data memory value of FSR0 not changed								N/A	N/A	*****		
01H	POINC0	Contents of FSR0 to address data memory value of FSR0 post-incremented								N/A	N/A	*****		
02H	PODEC0	Contents of FSR0 to address data memory value of FSR0 post-decremented								N/A	N/A	*****		
03H	PRINC0	Contents of FSR0 to address data memory value of FSR0 pre-incremented								N/A	N/A	*****		
04H	PLUSW0	Contents of FSR0 to address data memory value of FSR0 offset by W								N/A	N/A	*****		
05H	INDF1	Contents of FSR1 to address data memory value of FSR0 not changed								N/A	N/A	*****		
06H	POINC1	Contents of FSR1 to address data memory value of FSR0 post-incremented								N/A	N/A	*****		
07H	PODEC1	Contents of FSR1 to address data memory value of FSR0 post-decremented								N/A	N/A	*****		
08H	PRINC1	Contents of FSR1 to address data memory value of FSR0 pre-incremented								N/A	N/A	*****		
09H	PLUSW1	Contents of FSR1 to address data memory value of FSR0 offset by W								N/A	N/A	*****		
0FH	FSR0H	FSR0[8]							xu	*****		
10H	FSR0L	Indirect Data Memory Address Pointer 0 Low Byte,FSR0[7:0]								xxxx xxxx	uuuu uuuu	*****		
11H	FSR1H	FSR1[8]							xu	*****		
12H	FSR1L	Indirect Data Memory Address Pointer 1 Low Byte,FSR1[7:0]								xxxx xxxx	uuuu uuuu	*****		
16H	TOSH	TOS[11] TOS[10] TOS[9] TOS[8]							00000000	*****		
17H	TOSL	Top-of-Stack Low Byte (TOS<7:0>)								0000 0000	0000 0000	*****		
18H	STKPTR	STKFL	STKUN	STKOV	STKPRT[2:0]				000..000	000..000	r,r,w0,rw0,-,r,r,r			
1AH	PCLATH	PC[11] PC[10] PC[9] PC[8]							00000000	*****		
1BH	PCLATL	PC Low Byte for PC<7:0>								0000 0000	0000 0000	*****		
1DH	TBLPTRH	TBLPTR[11] TBLPTR[10] TBLPTR[9] TBLPTR[8]							00000000	*****		
1EH	TBLPTRL	Program Memory Table Pointer Low Byte (TBLPTR<7:0>)								0000 0000	0000 0000	*****		
1FH	TBLDH	Program Memory Table Latch High Byte								0000 0000	0000 0000	*****		
20H	TBLDL	Program Memory Table Latch Low Byte								0000 0000	0000 0000	*****		
21H	PRODH	Product Register of Multiply High Byte								xxxx xxxx	uuuu uuuu	r,r,r,r,r,r,r,r		
22H	PRODL	Product Register of Multiply Low Byte								xxxx xxxx	uuuu uuuu	r,r,r,r,r,r,r,r		
23H	INTE1	GIE	ADCIE	TMCIIE	TMBIE	TMAIE	WDTIE	E1IE	E0IE	0000 0000	0000 0000	*****		
24H	INTE2	TXIE	RCIE	SSPIE				CCP1IE	CCP0IE000000	*****		
26H	INTF1	ADCIF	TMCIF	TMBIF	TMAIF	WDTIF	E1IF	E0IF	.000 0000	.000 0000	*****			
27H	INTF2	SSPIF								CCP1IF	CCP0IF000000	*****
29H	WREG	Working Register								xxxx xxxx	uuuu uuuu	*****		
2AH	BSRNC	BSR[0]							00	*****		
2BH	STATUS	C DC N OV Z								...x xxxx	...u uuuu	*****		
2CH	PSTATUS	PD	TO	IDLEB	BOR	SKERR				000d .0.	uduu .d.	rw0,rw0,rw0,rw0,-,rw0,-		
2DH	LVDCN	LVDFG	LVD	LVDON	VLDX[3:0]				.000 0000	.000 uuuu	..,r,r,r *****			
30H	PWRNC	ENVDDA	VDDAX[1:0]	ENACM	0000				0000	0000	*****			
31H	MCKCN1	ADCS[2:0]		ADCK	XTHSP	XTSP	ENXT	ENHAO	0000 0001	0000 0001	*****			
32H	MCKCN2	LCK	HCK	HSS[1:0]		CPUCK[1:0]		.00 0000	.00 0000	..,r,r,r *****				
33H	MCKCN3	LCDS[2:0]		PERCK	BZS[2:0]			000. 0000	000. 0000	..,r,r,r *****				
37H	OPCN1	ENOP	OPM[1:0]	OPPI[1:0]	OPN[2:0]			0000 0000	0000 0000	*****				
39H	ADCRH	ADC conversion memory HighByte								xxxx xxxx	uuuu uuuu	r,r,r,r,r,r,r,r		
3AH	ADCRM	ADC conversion memory Middle Byte								xxxx xxxx	uuuu uuuu	r,r,r,r,r,r,r,r		
3BH	ADCNL	ADC conversion memory Low Byte								xxxx xxxx	uuuu uuuu	r,r,r,r,r,r,r,r		
3CH	ADCCN1	ENADC	ENHIGN	ENCHP	PGAGN[1:0]	ADGN[2:0]			0000 0000	0000 0000	*****			
3DH	ADCCN2	INBUF	VRBUF	VREGN	DCSET[2:0]			.00 0000	.00 0000	..,r,r,r *****				
3EH	ADCCN3	OSR[2:0]		000.				000.	000.,r,r,r *****				
3FH	AINET1	INH[2:0]		INL[2:0]		INIS	OPIS	0000 0000	0000 0000	*****				
40H	AINET2	VRH[1:0]	INX[1:0]	VRL[1:0]			.000 000.	.000 000.	..,r,r,r *****					
41H	TMACN	ENTMA	TMACK	TMAS[1:0]	ENWDT	WDTs[2:0]		0000 0000	0000 0000	**** w1,***				
42H	TMAR	TimerA data register								xxxx xxxx	uuuu uuuu	r,r,r,r,r,r,r,r		
43H	TMBCN	ENTMB	TMBCK	TMBS[1:0]	TMBSYC	TMBR2R	0000 00..		0000 00..	*****				
44H	TMBRH	TimerB High Byte data register								xxxx xxxx	uuuu uuuu	*****		
45H	TMBRL	TimerB Low Byte data register								xxxx xxxx	uuuu uuuu	*****		
46H	TMCCN	ENTMC	TMCCK[1:0]	TMCS[2:0]		TMCS0[1:0]		0000 0000	0000 0000	*****				
47H	PRC	TimerC programmable register								1111 1111	1111 1111	*****		
48H	TMCR	TimerC register								0000 0000	0000 0000	r,r,r,r,r,r,r,r		
49H	CCPCN	CCP1M[3:0]			CCP0M[3:0]			0000 0000	0000 0000	*****				
4AH	CCPORH	CCP0 High Byte data register								xxxx xxxx	uuuu uuuu	*****		
4BH	CCP0RL	CCP0 Low Byte data register								xxxx xxxx	uuuu uuuu	*****		
4CH	CCP1RH	CCP1 High Byte data register								xxxx xxxx	uuuu uuuu	*****		
4DH	CCP1RL	CCP1 Low Byte data register								xxxx xxxx	uuuu uuuu	*****		
4EH	PASC	PASF	PASCf[1:0]			0.00			0.00,r,r,r *****				
4FH	PWMCN	ENPWM	ENPFD	PWMRL[1:0]			0000		0000	****				
51H	PWMR	PWM MSB Byte register								xxxx xxxx	uuuu uuuu	*****		

Table 5-1(a) HY11P13 Register List

HY11P13

Embedded 18-Bit ΣΔADC

8-Bit RISC-like Mixed Signal Microcontroller



“-”no use, “w”read/write, “w”write, “r”read, “r0”only read 0, “r1”only read 1, “w0”only write 0, “w1”only write 1
 “.”unimplemented bit, “x”unknown, “u”unchanged, “d”depends on condition

Address	File Name	Bit7	Bit6	Bit5	Bit4	Bit3	Bit2	Bit1	Bit0	A-RESET	I-RESET	R/W
52H	LCDCN1	ENLCD	LCDCPR	VLCDX[1:0]		LCDCBF	LCDCBI[1:0]			0000 000.	0000 000.	*****-
53H	LCDCN2	LCDCBL	LCDCMX[1:0]							000.	000.	***- - - -
54H	LCD0	Segment SEG2@[3:0] and SEG3@[7:4] data register of LCD										
55H	LCD1	Segment SEG4@[3:0] and SEG5@[7:4] data register of LCD										
56H	LCD2	Segment SEG6@[3:0] and SEG7@[7:4] data register of LCD										
57H	LCD3	Segment SEG8@[3:0] and SEG9@[7:4] data register of LCD										
58H	LCD4	Segment SEG10@[3:0] and SEG11@[7:4] data register of LCD										
59H	LCD5	Segment SEG12@[3:0] and SEG13@[7:4] data register of LCD										
5AH	LCD6	Segment SEG14@[3:0] and SEG15@[7:4] data register of LCD										
5BH	LCD7	Segment SEG16@[3:0] and SEG17@[7:4] data register of LCD										
5CH	LCD8	Segment SEG18@[3:0] and SEG19@[7:4] data register of LCD										
5DH	LCD9	Segment SEG20@[3:0] and SEG21@[7:4] data register of LCD										
5EH	SSPCON1	SSPEN	CKP	CKE	SMP				SSPM<1:0>	0000 ..00	uuuu ..uu	***- - - -
60H	SSPSTA	SSPBUY	SSPOV						BF	00.. ...0	00.. ...0	r,r,-,-,-,f
61H	SSPBUF	SSP Receive Buffer/Transmit Register										
6DH	PT1	PT1.7	PT1.6	PT1.5	PT1.4	PT1.3	PT1.2	PT1.1	PT1.0	xxxx xxxx	uuuu uuuu	***r,r,f,r,f
6EH	TRISC1	TC1.7	TC1.6	TC1.5	TC1.4					0000	0000	***- - - -
6FH	PT1DA						DA1.2		0.0.	- - - - -
70H	PT1PU	PU1.7	PU1.6	PU1.5	PU1.4	PU1.3	PU1.2	PU1.1	PU1.0	0000 0000	0000 0000	***r,r,f,r,f
71H	PT1M1					INTEG1[1:0]		INTEG0[1:0]		... 0000	... 0000	- - - - -
72H	PT1M2		PM1.7[0]		PM1.6[0]		PM1.5[0]			.0.0 .0.	.0.0 .0.	- - - - -
74H	PT2			PT2.5	PT2.4	PT2.3	PT2.2	PT2.1	PT2.0	..xx xxxx	..uu uuuu	- - - - -
75H	TRISC2			TC2.5	TC2.4	TC2.3	TC2.2	TC2.1	TC2.0	..00 0000	..00 0000	- - - - -
77H	PT2PU			PU2.5	PU2.4	PU2.3	PU2.2	PU2.1	PU2.0	..00 0000	..00 0000	- - - - -
78H	PT2M1			PM2.2[1]	PM2.2[0]					..0000	- - - - -
79H	PT2M2	PWMTR[1]	PWMTR[0]			PM2.5[1]	PM2.5[0]	PM2.4[1]	PM2.4[0]	00.. 0000	00.. 0000	** - - - -
80H ~ FFH	GPR0	General Purpose Register as 128Byte										
100H~17FH	GPR1	General Purpose Register as 128Byte										

Figure 5-1(b) HY11P13 Register List (continued)

6. Electrical Characteristics

Absolute maximum ratings over operating free-air temperature (unless otherwise noted)

Voltage applied at V_{DD} to V_{SS}	-0.2 V to 4.0 V
Voltage applied to any pin	-0.2 V to $V_{DD} + 0.3$ V
Voltage applied to RST/VPP pin	-0.2 V to 6.9 V
Voltage applied to TST/PT1.3 pin	-0.2 V to $V_{DD} + 1$ V
Diode current at any device terminal	± 2 mA
Storage temperature, Tstg: (unprogrammed device)	-55°C to 150°C
(programmed device)	-40°C to 85°C
Total power dissipation.	0.5w
Maximum output current sink by any PORT1 to PORT3 I/O Pin.25mA

6.1. Recommended operating conditions

$T_A = -40^\circ\text{C} \sim 85^\circ\text{C}$, unless otherwise noted

Sym.	Parameter		Test Conditions		Min.	Typ.	Max.	unit
V_{DD}	Supply Voltage		All digital peripherals and CPU		2.2		3.6	V
			Analog peripherals		2.4		3.6	
V_{SS}	Supply Voltage				0		0	
XT	External	Watch crystal	$V_{DD} = 2.2\text{V}$, ENXT[0]=1	XTSP[0]=0, XTHSP[0]=0	32.768K		Hz	
	Oscillator	Ceramic resonator		XTSP[0]=1, XTHSP[0]=0	450K	8M		
	Frequency	Crystal		XTSP[0]=1, XTHSP[0]=0	1M	8M		

HY11P13

Embedded 18-Bit $\Sigma\Delta$ ADC

8-Bit RISC-like Mixed Signal Microcontroller

6.2. Internal RC Oscillator

$T_A = 25^\circ\text{C}, V_{DD} = 3.0\text{V}$, unless otherwise noted

Sym.	Parameter	Test Conditions	Min.	Typ.	Max.	unit
HAO	High Speed Oscillator frequency	ENHAO[0]=1	1.8	2.0	2.2	MHz
LPO	Low Power Oscillator frequency	V_{DD} supply voltage be enable LPO	22	28	35	KHz

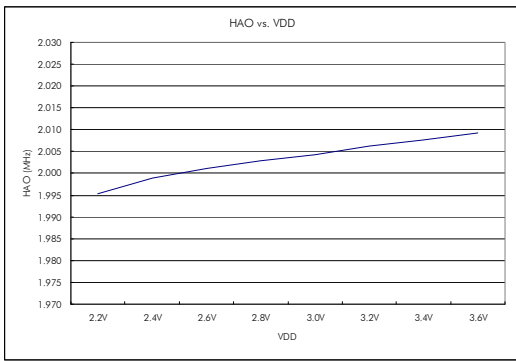

Figure 6.2-1 HAO vs. VDD

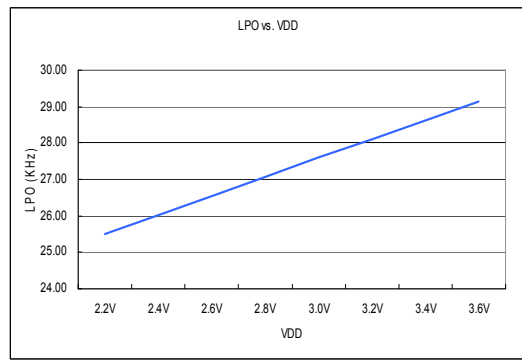

Figure 6.2-2 LPO vs. VDD

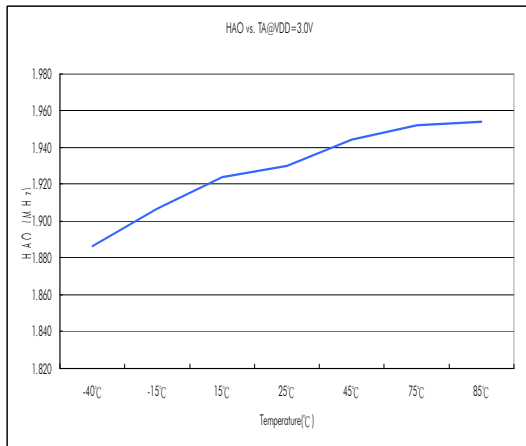

Figure 6.2-3 HAO vs. Temperature

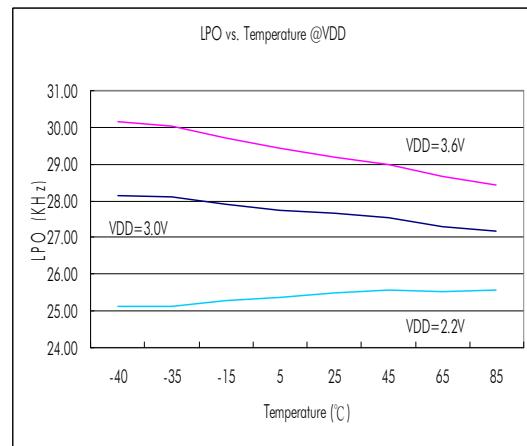

Figure 6.2-4 LPO vs. Temperature

6.3. Supply Current into VDD Excluding Peripherals Current

$T_A = 25^\circ\text{C}, V_{DD} = 3.0\text{V}, \text{OSC_LPO} = 28\text{KHz}$, unless otherwise noted

Sym.	Parameter	Test Conditions	Min.	Typ.	Max.	unit
I_{AM1}	Active mode 1	OSC_CY = 8MHz, OSC_HAO = off, CPU_CK = 8MHz		1.2	2	mA
I_{AM2}	Active mode 2	OSC_CY = off, OSC_HAO = 2MHz, CPU_CK = 2MHz		0.32	0.55	mA
I_{AM3}	Active mode 3	OSC_CY = off, OSC_HAO = 2MHz, CPU_CK = 1MHz		0.18	0.3	mA
I_{LP1}	Low Power 1	OSC_CY = 32768Hz, OSC_HAO = off, CPU_CK = 16384Hz		7	12	uA
I_{LP2}	Low Power 2	OSC_CY = off, OSC_HAO = off, CPU_CK = LPO, Idle state		1.65	3	uA
I_{LP3}	Low Power 3	OSC_CY = off, OSC_HAO = off, CPU_CK = off, Sleep state		0.65	1.2	uA

OSC_CY : External Oscillator frequency.

OSC_HAO : Internal High Accuracy Oscillator frequency.

CPU_CK : CPU core work frequency.

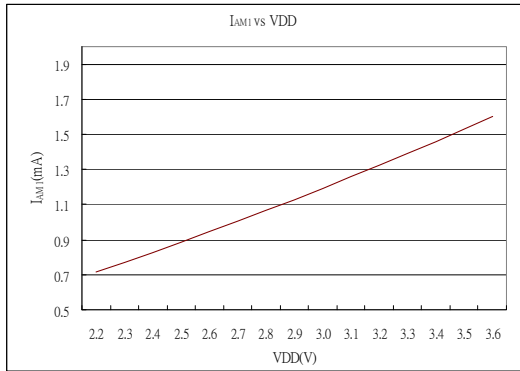

Figure 6.3-1 I_{AM1} vs. VDD

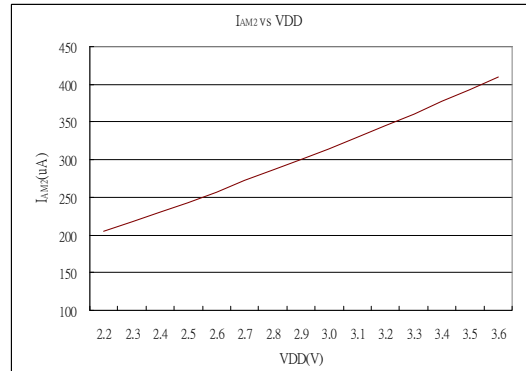

Figure 6.3-2 I_{AM2} vs. VDD

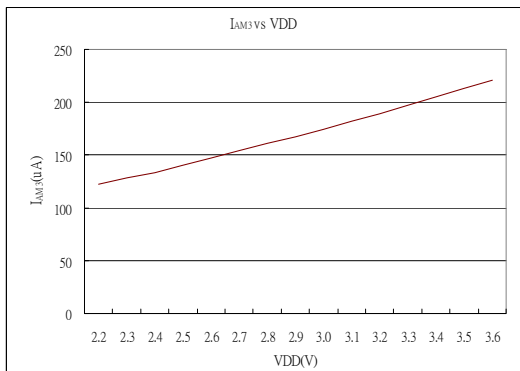

Figure 6.3-3 I_{AM3} vs. VDD

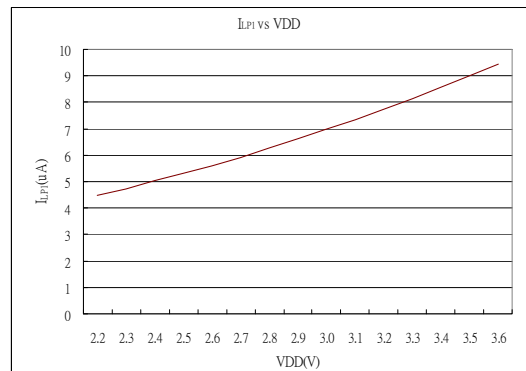

Figure 6.3-4 I_{LP1} vs. VDD

HY11P13

Embedded 18-Bit $\Sigma\Delta$ ADC

8-Bit RISC-like Mixed Signal Microcontroller

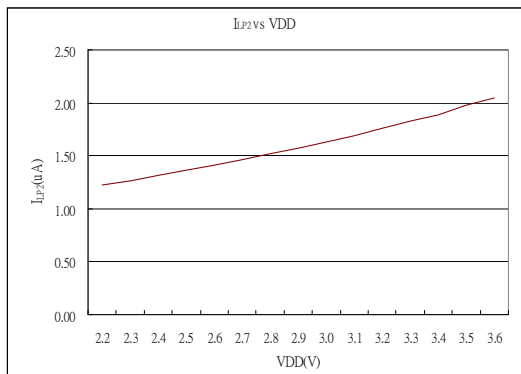

Figure 6.3-5 ILP2 vs. VDD

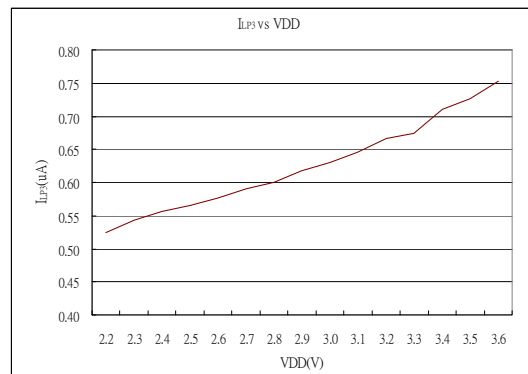

Figure 6.3-6 ILP3 vs. VDD

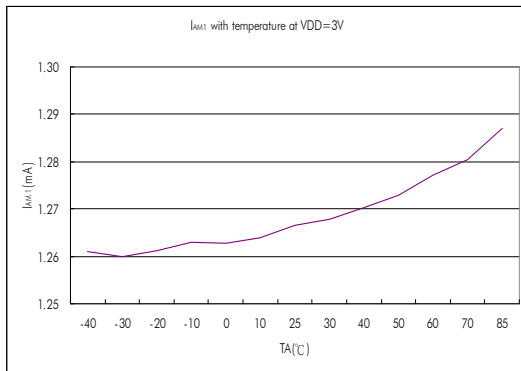

Figure 6.3-7 I_{AM1} vs. Temperature

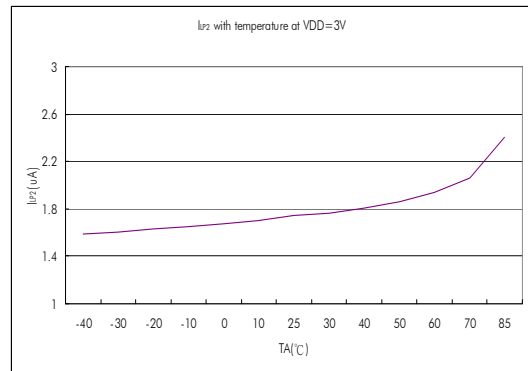

Figure 6.3-8 ILP2 vs. Temperature

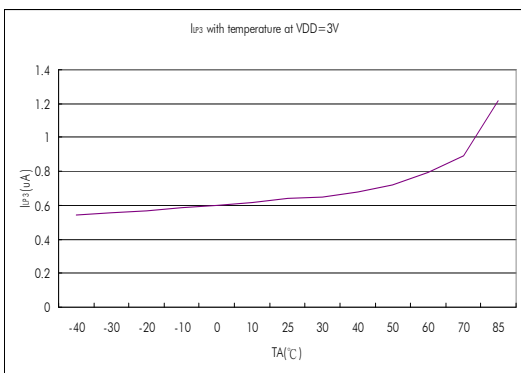

Figure 6.3-9 ILP3 vs. Temperature

6.4. Port1~2

$T_A = 25^\circ\text{C}, V_{DD} = 3.0\text{V}$, unless otherwise noted

Sym.	Parameter	Test Conditions	Min.	Typ.	Max.	unit
Input voltage and Schmitt trigger and leakage current and timing						
V_{IH}	High-Level input voltage				2.1	V
V_{IL}	Low-Level input voltage		0.9			
V_{hys}	Input Voltage hysteresis($V_{IH} - V_{IL}$)			0.8		V
I_{LKG}	Leakage Current				0.1	μA
R_{PU}	Port pull high resistance			180		$\text{k}\Omega$
Output voltage and current and frequency						
V_{OH}	High-level output voltage	$I_{OH}=10\text{mA}$	$V_{DD} - 0.3$			V
V_{OL}	Low-level output voltage	$I_{OL}=-10\text{mA}$	$V_{SS} + 0.3$			

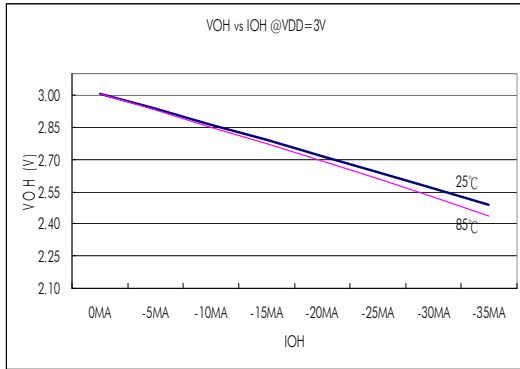

Figure 6.4-1 V_{OH} vs. I_{OH} @ $V_{DD}=3.0\text{V}$

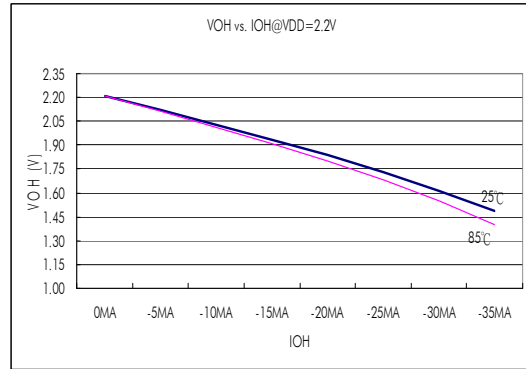

Figure 6.4-2 V_{OH} vs. I_{OH} @ $V_{DD}=2.2\text{V}$

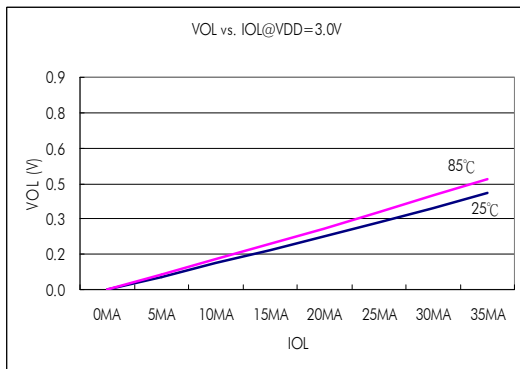

Figure 6.4-3 V_{OL} vs. I_{OL} @ $V_{DD}=3.0\text{V}$

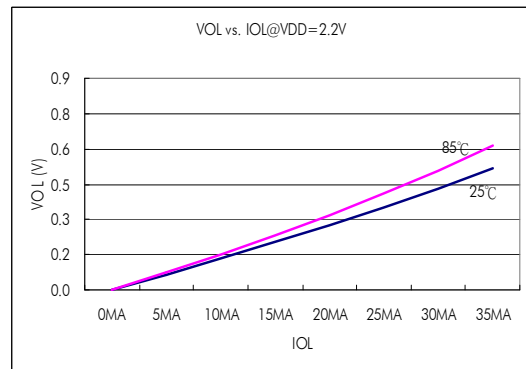

Figure 6.4-4 V_{OL} vs. I_{OL} @ $V_{DD}=2.2\text{V}$

6.5. Reset (Brownout, External RST pin, Low Voltage Detect)

$T_A = 25^\circ\text{C}, V_{DD} = 3.0\text{V}$, unless otherwise noted

Sym.	Parameter	Test Conditions	Min.	Typ.	Max.	unit	
BOR	Pulse length needed to accepted reset internally, t_{d-LVR}		2			us	
	V_{DD} Start Voltage to accepted reset internally (L \rightarrow H), V_{LVR}		1.6	1.85	2.1	V	
	Hysteresis, $V_{HYS-LVR}$			70		mV	
RST	Pulse length needed as RST/VPP pin to accepted reset internally, t_{d-RST}		2			us	
	Input Voltage to accepted reset internally		0.9			V	
	Hysteresis, $V_{HYS-RST}$			0.8		V	
LVD	Operation current, I_{LVD}			10	15	uA	
	External input voltage to compare reference voltage			1.2		V	
	Compare reference voltage temperature drift	$T_A = -40^\circ\text{C} \sim 85^\circ\text{C}$		100		ppm/ $^\circ\text{C}$	
	Detect V_{DD} voltage rang by user option, $V_{SVS} VLDx[3:0]=1110b$			3.3		V	
	Detect V_{DD} voltage rang by user option, $V_{SVS} VLDx[3:0]=1101b$			3.2			
	Detect V_{DD} voltage rang by user option, $V_{SVS} VLDx[3:0]=1100b$			3.1			
	Detect V_{DD} voltage rang by user option, $V_{SVS} VLDx[3:0]=1011b$			3.0			
	Detect V_{DD} voltage rang by user option, $V_{SVS} VLDx[3:0]=1010b$			2.9			
	Detect V_{DD} voltage rang by user option, $V_{SVS} VLDx[3:0]=1001b$			2.8			
	Detect V_{DD} voltage rang by user option, $V_{SVS} VLDx[3:0]=1000b$			2.7			
	Detect V_{DD} voltage rang by user option, $V_{SVS} VLDx[3:0]=0111b$			2.6			
	Detect V_{DD} voltage rang by user option, $V_{SVS} VLDx[3:0]=0110b$			2.5			
	Detect V_{DD} voltage rang by user option, $V_{SVS} VLDx[3:0]=0101b$			2.4			
	Detect V_{DD} voltage rang by user option, $V_{SVS} VLDx[3:0]=0100b$			2.3			
	Detect V_{DD} voltage rang by user option, $V_{SVS} VLDx[3:0]=0011b$			2.2			
	Detect V_{DD} voltage rang by user option, $V_{SVS} VLDx[3:0]=0010b$			2.1			
Detect V_{DD} voltage rang by user option, $V_{SVS} VLDx[3:0]=0001b$			2.0				
BOR : Brownout Reset LVR : Low Voltage Reset of BOR LVD : Low Voltage Detect RST : External Reset pin							

HY11P13

Embedded 18-Bit $\Sigma\Delta$ ADC

8-Bit RISC-like Mixed Signal Microcontroller

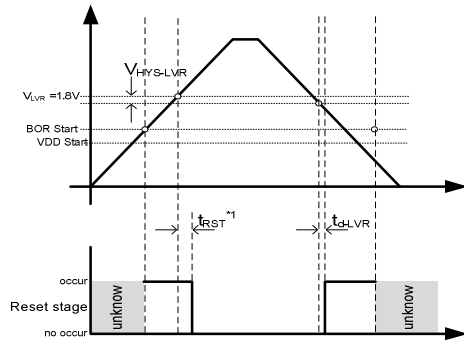

Figure 6.5-1 BOR Reset Diagram

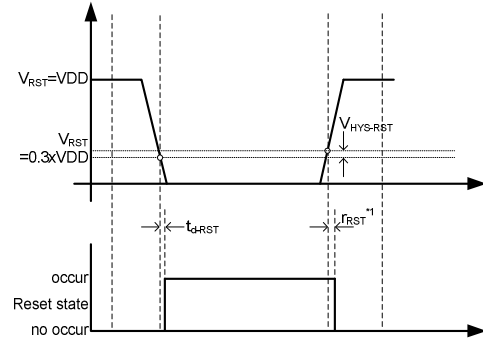

Figure 6.5-2 RST Reset Diagram

*1 t_{RST} : Please see BOR Introduce of HY11Pxx series User's Guide (UG-HY11S14-Vxx).

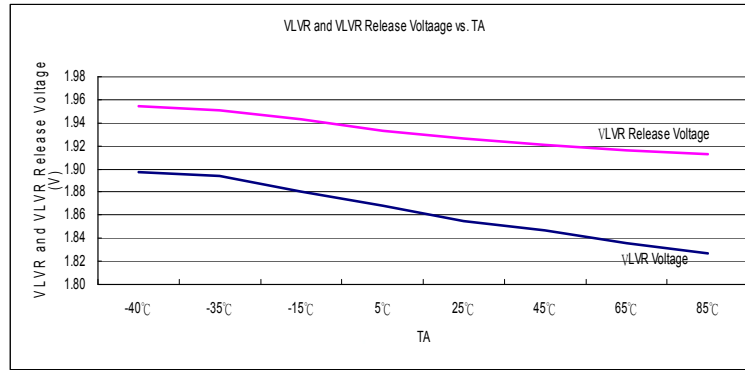

Figure 6.5-3 LVR vs. Temperature

6.6. Power System

$T_A = 25^\circ\text{C}, V_{DD} = 3.0\text{V}$, unless otherwise noted

Sym.	Parameter	Test Conditions		Min.	Typ.	Max.	unit
VDDA	VDDA operation current, I_{VDDA}	$I_L = 0\text{mA}$	VDDAX[1:0]=00b		22		μA
	Select VDDA output voltage	$I_L = 0.1\text{mA}$, $V_{DD} \geq V_{VDDA} + 0.2\text{V}$	VDDAX[1:0]=00b		3.3		V
			VDDAX[1:0]=01b		2.9		V
			VDDAX[1:0]=10b		2.6		V
			VDDAX[1:0]=11b		2.4		V
	Dropout voltage	$I_L = 10\text{mA}$	VDDAX[1:0]=00b		135		mV
			VDDAX[1:0]=01b		150		mV
VDDAX[1:0]=10b				165		mV	
VDDAX[1:0]=11b				180		mV	
Temperature drift	VDDAX[1:0]=11b	$T_A = -40^\circ\text{C} \sim 85^\circ\text{C}$		50		ppm/ $^\circ\text{C}$	
V_{DD} Voltage drift	$I_L = 0.1\text{mA}$	$V_{DD} = 2.5\text{V} \sim 3.6\text{V}$		± 0.2		%/V	
ACM	ACM operation current, I_{ACM}	$I_L = 0\text{mA}$			20		μA
	Output voltage, V_{ACM}	ENACM[0]=1	$I_L = 0\mu\text{A}$		1.0		V
	Output voltage with Load		$I_L = \pm 200\mu\text{A}$	0.98		1.02	V_{ACM}
	Temperature drift	ENACM[0]=1,	$T_A = -40^\circ\text{C} \sim 85^\circ\text{C}$		50		ppm/ $^\circ\text{C}$
	VDDA Voltage drift	$I_L = 10\mu\text{A}$			100		$\mu\text{V}/\text{V}$

VDDA : Adjust Voltage Regulator
ACM : Analog Common Mode Voltage

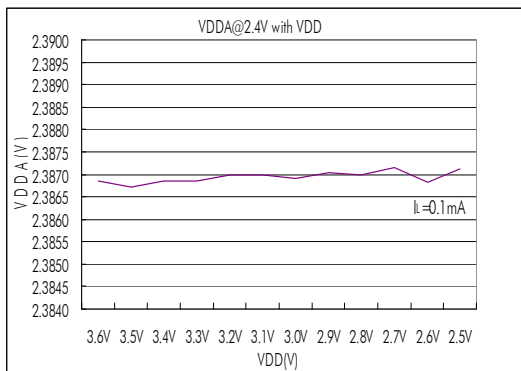

Figure 6.6-1 VDDA $I_L=0.1\text{mA}$ vs. VDD

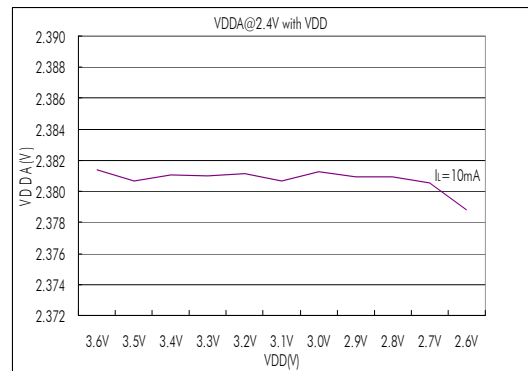

Figure 6.6-2 VDDA $I_L=10\text{mA}$ vs. VDD

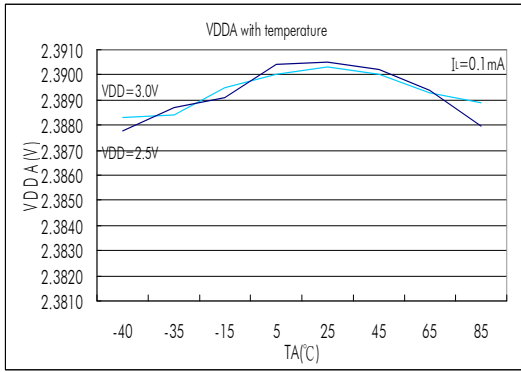

Figure 6.6-3 VDDA IL=0.1mA vs. Temperature

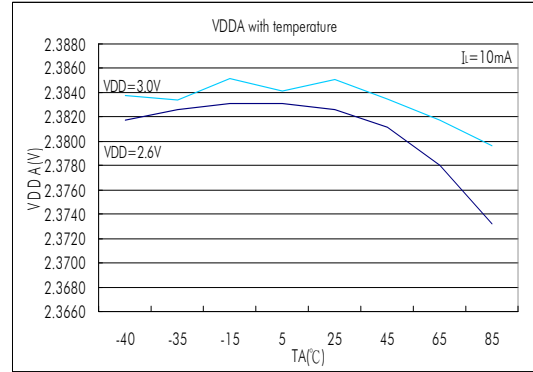

Figure 6.6-4 VDDA IL=10mA vs. Temperature

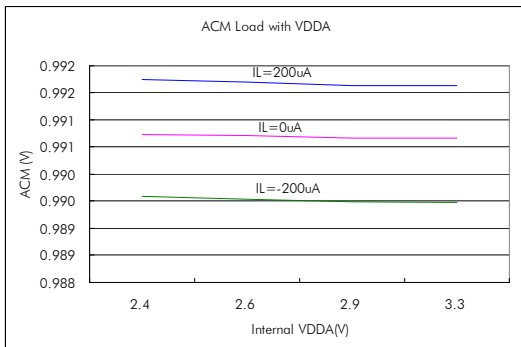

Figure 6.6-5 ACM Load vs. VDDA

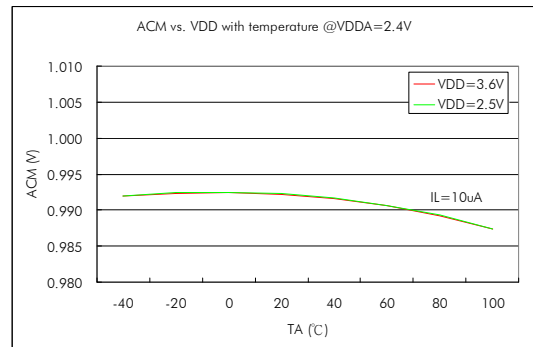

Figure 6.6-6 ACM vs. Temperature

6.7. LCD

$T_A = 25^\circ\text{C}$, $V_{DD} = 3.0\text{V}$, $C_{VLCD} = 4.7\mu\text{F}$, unless otherwise noted.

Sym.	Parameter	Test Conditions		Min.	Typ.	Max.	unit
I_{LCD}	Operation supply current without output buffer.(all segment turn on)	LCDPR[0]=1	$V_{DD} = 2.2\text{V}$	10			uA
			$V_{DD} = 3.0\text{V}$				
VLCD	Supply Voltage at VLCD pin	LCDPR[0]=0		2.2		3.6	V
	Embedded Charge Pump output voltage at VLCD pin	$V_{DD} = 2.2\text{V}$, LCDPR[0]=1, $C_{VLCD} = 4.7\mu\text{F}$	VLCDX[1:0]=11b	2.295	2.55	2.805	V
			VLCDX[1:0]=10b	2.52	2.8	3.08	
			VLCDX[1:0]=01b	2.745	3.05	3.355	
VLCDX[1:0]=00b	2.97	3.3	3.63				
Z_{LCD}	Output impedance with LCD buffer	$f_{LCD} = 128\text{Hz}$, VLCD=3.05V		10			k Ω

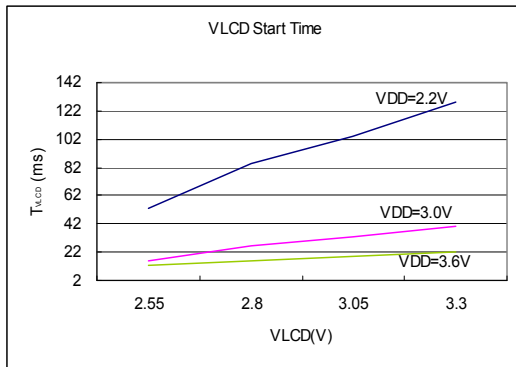

Figure 6.7-1 LCD start time

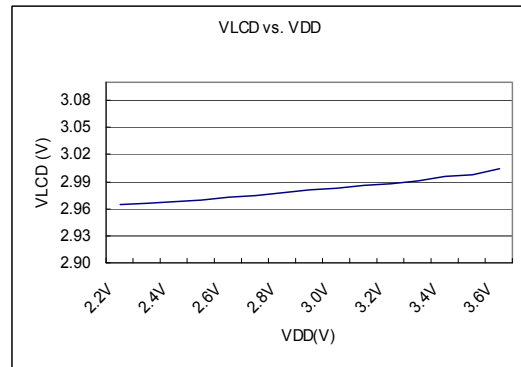

Figure 6.7-2 VLCD vs. VDD

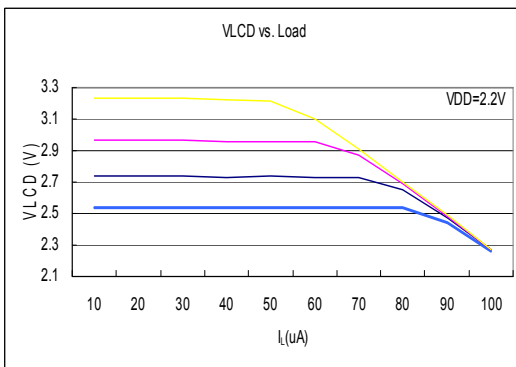

Figure 6.7-3 VLCD vs. I_L @ VDD=2.2V

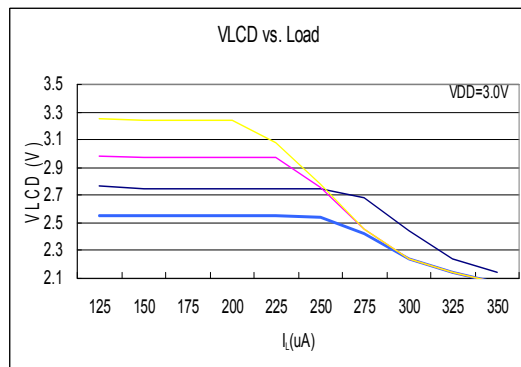

Figure 6.7-4 VLCD vs. I_L @ VDD=3.0V

HY11P13

Embedded 18-Bit $\Sigma\Delta$ ADC

8-Bit RISC-like Mixed Signal Microcontroller

6.8. Low Noise OPAMP

$T_A = 25^\circ\text{C}$, $V_{DD} = 3.0\text{V}$, $V_{DDA} = 2.4\text{V}$, unless otherwise noted

Sym.	Parameter	Test Conditions		Min.	Typ.	Max.	unit
V_{LNOF}	Supply voltage at VDDA	ENVDDA[0]=0		2.4		3.6	V
I_{LNOF}	Operation supply current		OPM[1:0]=xxb		200		μA
V_{OS-OP}	Input offset voltage without chopper.		OPM[1:0]=1xb	-2		2	mV
	Input offset voltage with chopper		OPM[1:0]=0xb		20		μV
	Input offset voltage temperature drift.	OPM[1:0]=00b OPM[1:0]=10	$T_A = -40^\circ\text{C} \sim 85^\circ\text{C}$		0.1 2		$\mu\text{V}/^\circ\text{C}$
V_{OLR}	Unit gain load regulation	$V_O = 1.2\text{V}$, $V_{DDA} = 2.4\text{V}$	$I_L = +1\text{mA}$ $I_L = -1\text{mA}$		0.1		$\%V_O$
CMVR	Common-mode voltage input range		OPM[1:0]=xxb	0.1		$V_{DDA} - 1.1$	V
CMRR	Common-mode rejection ratio		OPM[1:0]=xxb		90		dB

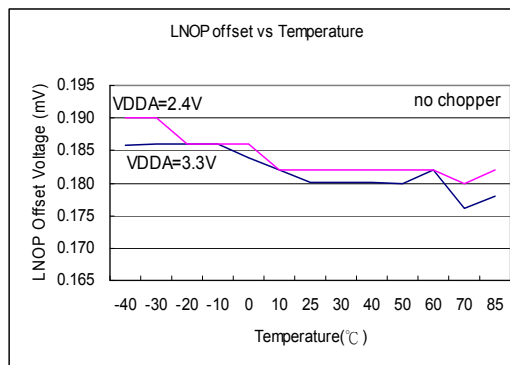

Figure 6.8-1 LNOP Offset Temperature

6.9. SD18, Power Supply and Recommended Operating Conditions

$T_A = 25^\circ\text{C}, V_{DD} = 3.0\text{V}, V_{DDA}=2.4\text{V}$, unless otherwise noted

Sym.	Parameter	Test Conditions	Min.	Typ.	Max.	unit
V_{SD18}	Supply Voltage at VDDA	ENVDDA[0]=0	2.4		3.6	V
f_{SD18}	Modulator sample frequency, ADC_CK		25	250	300	KHz
	Over Sample Ratio, OSR		256		32768	
I_{SD18}	Operation supply current without PGA	ENADC[0]=1 INBUF[0]=1,VRBUF[0]=0	GAIN =4, ADC_CK=250KHz		168	uA
		ENADC[0]=1 INBUF[0]=0,VRBUF[0]=1		150		
		ENADC[0]=1 INBUF[0]=0,VRBUF[0]=0		120		

6.9.1 PGA, Power Supply and Recommended Operating Conditions

$T_A = 25^\circ\text{C}, V_{DD} = 3.0\text{V}, V_{DDA}=2.4\text{V}$, unless otherwise noted

Sym.	Parameter	Test Conditions	Min.	Typ.	Max.	unit
V_{PGA}	Supply Voltage at VDDA	ENVDDA[0]=0	2.4		3.6	V
I_{PGA}	Operation supply current	PGAGN[1:0]=<01>or<1x>		320		uA
G_{PGA}	Gain temperature drift	$T_A = -40^\circ\text{C} \sim 85^\circ\text{C}$ GAIN=128		5		ppm/ $^\circ\text{C}$

6.9.2 SD18, Performance II ($f_{SD18}=250\text{KHz}$)

$T_A = 25^\circ\text{C}, V_{DD} = 3.0\text{V}, V_{DDA}=2.9\text{V}, V_{VR}=1.0\text{V}, \text{GAIN}=1$ without PGA, unless otherwise noted

Sym.	Parameter	Test Conditions	Min.	Typ.	Max.	unit
INL	Integral Nonlinearity(INL)	$V_{DDA}=2.4\text{V}, V_{VR}=1.0\text{V}, \Delta \text{SI}=\pm 200\text{mV}$		± 0.003	± 0.01	%FSR
		$V_{DDA}=2.4\text{V}, V_{VR}=1.0\text{V}, \Delta \text{SI}=\pm 450\text{mV}$				
	No Missing Codes ³	ADC_CK=250KHz, OSR[2:0]=010b	23			Bits
G_{SD18}	Temperature drift Gain 1~x16 (INBUF[0]=0b,) Gain 1~x4 (INBUF[0]=1b,)	INBUF[0]=0b,VRBUF[0]=0b	$T_A = -40^\circ\text{C} \sim 85^\circ\text{C}$	2		ppm/ $^\circ\text{C}$
		INBUF[0]=1b,VRBUF[0]=0b				
		INBUF[0]=0b,VRBUF[0]=1b				
		INBUF[0]=1b,VRBUF[0]=1b				
E_{OS}	Offset error of Full Scale Rang input voltage range with Chopper and Buffer(INBUF,VRBUF) without PGA	$\Delta \text{AI}=0\text{V}$ $\Delta \text{VR}=0.9\text{V}$ DCSET[2:0]=<000>	Gain=2		1	%FSR
		* ΔAI is external short	Gain=2		1	
	Offset error of Full Scale Rang input voltage range with Chopper without PGA and Buffer(INBUF,VRBUF)					
E_{OS}	Offset temperature drift with chopper without PGA and Buffer (INBUF,VRBUF).		GAIN=1	2		uV/ $^\circ\text{C}$
			GAIN=2	1		
			GAIN=4	0.5		

HY11P13

Embedded 18-Bit $\Sigma\Delta$ ADC

8-Bit RISC-like Mixed Signal Microcontroller

			GAIN=16	0.15	
	Offset temperature drift with chopper and Buffer (INBUF,VRBUF) without PGA.		GAIN=1	2	
			GAIN=2	1	
			GAIN=4	0.5	
	Offset temperature drift with chopper without Buffer (INBUF,VRBUF).		GAIN=128	0.02	
CM _{SD18}	Common-mode rejection	V _{CM} =0.7V to 1.7V, V _{VR} =1.0V, without PGA	V _{SI} =0V, GAIN=1	90	dB
		V _{CM} =0.7V to 1.7V, V _{VR} =1.0V, without PGA	V _{SI} =0V, GAIN=16	75	
PSRR	DC power supply rejection	V _{DDA} =3.0V, Δ V _{DDA} = \pm 100mV, V _{VR} =1.0V, V _{SI} =1.2V, V _{SI} =1.2V,	GAIN=1 PGA=off	75	dB
			GAIN=16 PGA=8		

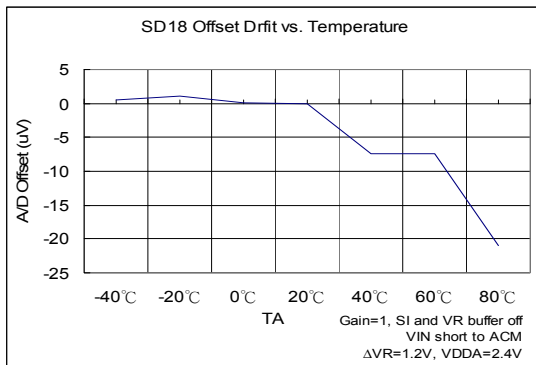

Figure 6.9-1(a) SD18 Offset Temperature Drift

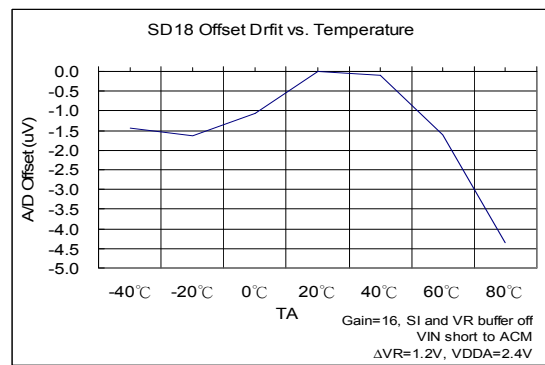

Figure 6.9-1(b) SD18 Offset Temperature Drift

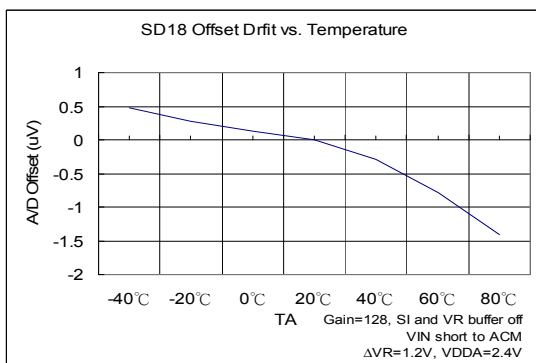

Figure 6.9-1(c) SD18 Offset Temperature Drift

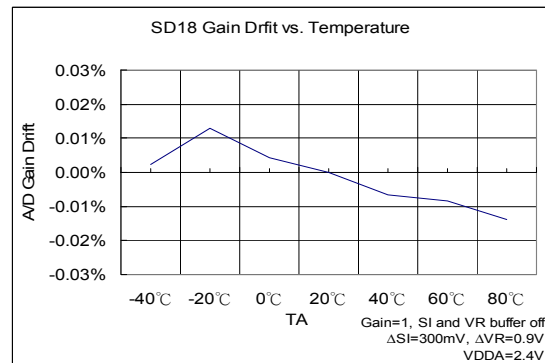

Figure 6.9-2(a) SD18 Gain Drift with Temperature

HY11P13

Embedded 18-Bit $\Sigma\Delta$ ADC

8-Bit RISC-like Mixed Signal Microcontroller

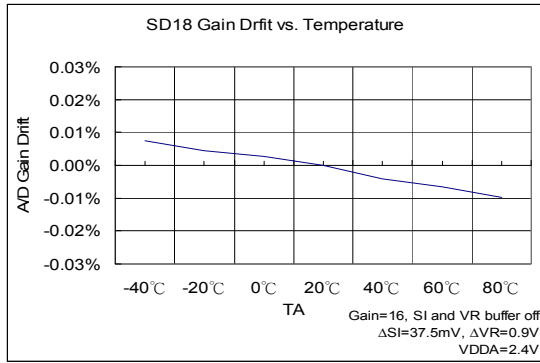

Figure 6.9-2(b) SD18 Gain Drift with Temperature

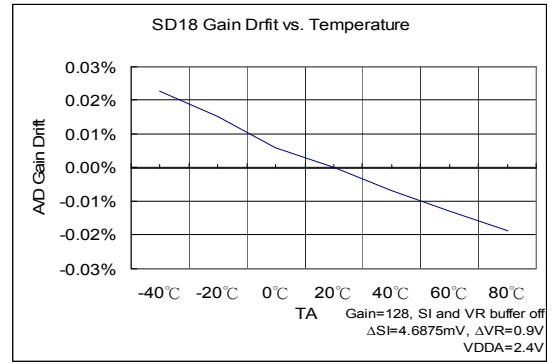

Figure 6.9-2(c) SD18 Gain Drift with Temperature

6.9.3 SD18, Temperature Sensor

$T_A = 25^\circ\text{C}, V_{DD} = 3.0\text{V}, V_{DDA} = 3.3\text{V}$, unless otherwise noted

Sym.	Parameter	Test Conditions	Min.	Typ.	Max.	unit
TC_S	Sensor temperature drift	$\Delta VR=2.4\text{V}, VRGN[0]=1,$		178		$\mu\text{V}/^\circ\text{C}$
KT	Absolute Temperature Scale 0°K	INBUF[0]=1		-289		$^\circ\text{C}$
TC_{ERR}	One point calibrate error temperature	Calibration at 25°C of $-40^\circ\text{C} \sim 85^\circ\text{C}$		± 2		$^\circ\text{C}$

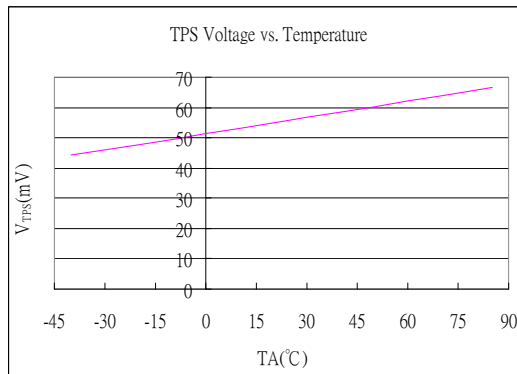

Figure 6.9-3 TPS Output Voltage vs. Temperature Drift

6.9.4 SD18 Noise Performance

$T_A = 25^\circ\text{C}, V_{DD} = 3.0\text{V}, V_{DDA} = 2.4\text{V}$, unless otherwise noted

HY11P13 provides important input noise specification that aims at SD18. Table 6.9-4(a) and Table 6.9-4(b) lists out the relations of typical noise specification, gain, output rate and maximum input voltage of single end. Test conditions are external input signal short, voltage reference: 1.2V and 1024 records were sampled.

ENOB(RMS) with OSR/GAIN at A/D Clock=250Khz, VDDA=2.4V, VREF=1.2V													
Max. Vin(mV) =0.9*VREF ⁽¹⁾	OSR					256	512	1024	2048	4096	8192	16384	32768
	Output rate(HZ)					977	488	244	122	61	31	15	8
	Gain	=	PGA	x	ADGN								
± 2400	0.25	=	1	x	0.25	16.3	17.4	17.9	18.5	19.0	19.5	20.0	20.4
± 2160	0.5	=	1	x	0.5	16.3	17.3	17.9	18.4	18.9	19.4	19.8	20.2
± 1080	1	=	1	x	1	16.2	17.2	17.8	18.3	18.8	19.3	19.7	20.1
± 540	2	=	1	x	2	16.1	17.1	17.6	18.2	18.7	19.2	19.6	20.0
± 270	4	=	1	x	4	16.0	16.9	17.5	18.0	18.5	18.9	19.4	19.8
± 135	8	=	1	x	8	15.9	16.6	17.2	17.7	18.2	18.7	19.2	19.6
± 68	16	=	1	x	16	15.6	16.3	16.8	17.3	17.7	18.3	18.8	19.3
± 34	32	=	2	x	16	14.8	15.3	15.9	16.4	16.9	17.4	17.8	18.3
± 17	64	=	4	x	16	14.5	15.0	15.5	16.0	16.5	17.0	17.5	18.0
± 8	128	=	8	x	16	14.0	14.6	15.1	15.6	16.0	16.6	17.0	17.5

(1) Max.Vin (mV) is the max. input voltage of single end to ground (VSS).

Table 6.9-4(a) SD18 ENOB Table

RMS Noise(uV) with OSR/GAIN at A/D Clock=250Khz, VDDA=2.4V, VREF=1.2V													
Max. Vin(mV) =0.9*VREF	OSR					256	512	1024	2048	4096	8192	16384	32768
	Output rate(HZ)					977	488	244	122	61	31	15	8
	Gain	=	PGA	x	ADGN								
± 2400	0.25	=	1	x	0.25	121.08	57.40	38.74	26.66	18.39	13.21	9.49	6.98
± 2160	0.5	=	1	x	0.5	61.63	29.23	19.21	13.51	9.78	7.02	5.12	3.91
± 1080	1	=	1	x	1	32.21	15.70	10.25	7.31	5.19	3.77	2.80	2.13
± 540	2	=	1	x	2	16.59	8.54	5.91	4.06	2.86	2.06	1.48	1.12
± 270	4	=	1	x	4	9.00	4.84	3.33	2.37	1.67	1.19	0.87	0.65
± 135	8	=	1	x	8	5.04	2.97	2.02	1.44	1.01	0.73	0.51	0.39
± 68	16	=	1	x	16	3.03	1.84	1.29	0.92	0.70	0.46	0.33	0.24
± 34	32	=	2	x	16	2.61	1.81	1.27	0.89	0.62	0.45	0.32	0.23
± 17	64	=	4	x	16	1.66	1.13	0.80	0.56	0.41	0.29	0.20	0.14
± 8	128	=	8	x	16	1.13	0.77	0.55	0.38	0.28	0.19	0.14	0.10

Table 6.9-4(b) SD18 RMS Noise Table

The RMS noise are referred to the input. The Effective Number of Bits (ENOB(RMS Bit)) is defined as:

$$\text{ENOB(RMS)} = \frac{\ln\left(\frac{\text{FSR}}{\text{RMS Noise}}\right)}{\ln(2)}$$

$$\text{RMS Noise} = \frac{\left(2 \times \text{VREF} \times \sqrt{\sum_{k=1}^{1024} (\text{ADO}[k] - \text{Average})^2}\right)}{2^{23}}$$

Where FSR (Full - Scale Range) = $2 \times \text{VREF}/\text{Gain}$.

$$\text{Average} = \frac{\sum_{k=1}^{1024} (\text{ADO}[k])}{1024}$$

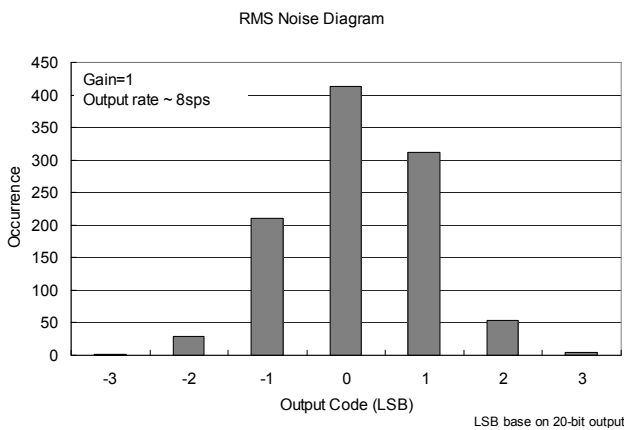

Figure 6.9-4(a) RMS Noise Diagram

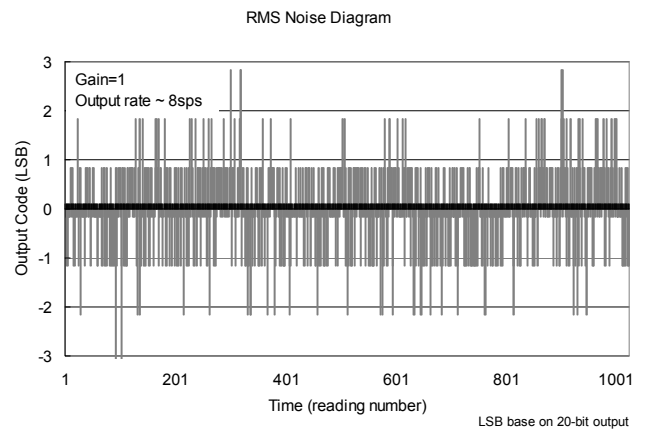

Figure 6.9-4(b) Output Code Diagram

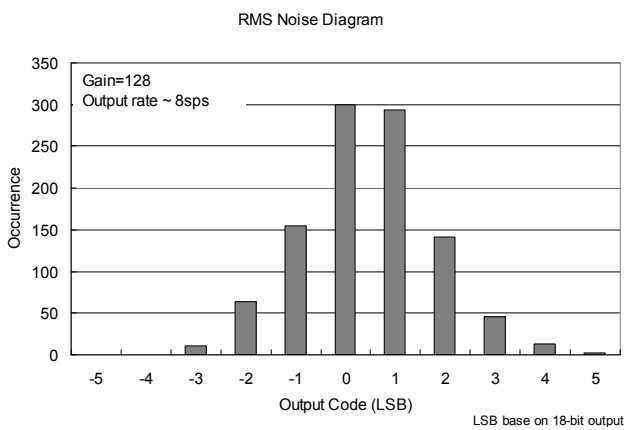

Figure 6.9-4(c) RMS Noise Diagram

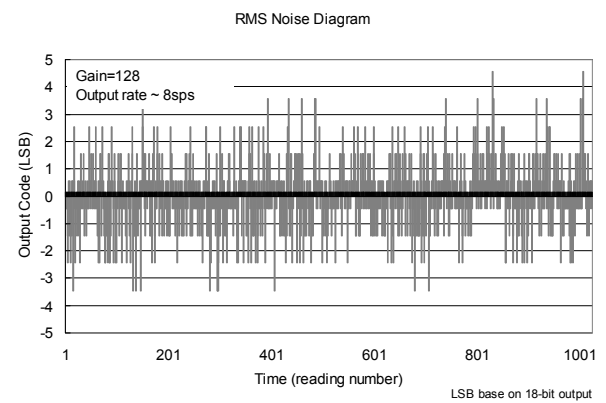

Figure 6.9-4(d) Output Code Diagram

HY11P13

Embedded 18-Bit Σ ADC

8-Bit RISC-like Mixed Signal Microcontroller

7. Ordering Information

Device No. ¹	Package Type	Pins	Package Drawing		Code ²	Shipment Packing Type	Unit Q'ty	Material Composition	MSL ³
HY11P13-D000	Die	-	D	000	000	-	100	Green ⁴	-
HY11P13-L064	LQFP	64	L	064	000	Tray	160	Green ⁴	MSL-3
HY11P13-LS64	LQFP	64	L	S64	000	Tray	250	Green ⁴	MSL-3

¹ **Device No.:** Model No. – Package Type Description – Code (Blank Code/ Standard/ Customized Programming Code)

Ex: Your customized programming code is 008 and you require die shipment.

The device No. will be HY11P13-D000-008.

Ex: You request blank code in die package.

The device No. will be HY11P13-D000.

Ex: You request blank code in LQFP 64 package.

The device No. will be HY11P13-L064.

And please clearly indicate the shipment packing type when placing orders.

Ex: Your customized programming code is 009 and you require products in LQFP 64 package.

The device No. will be HY11P13-LS64-009.

And please clearly indicate the shipment packing type when placing orders.

² **Code:**

“001”~ “999” is standard or customized programming code. Blank code does not have these numbers.

³ **MSL:**

The Moisture Sensitivity Level ranking conforms to IPC/JEDEC J-STD-020 industry standard categorization. The products are processed, packed, transported and used with reference to IPC/JEDEC J-STD-033.

⁴ **Green (RoHS & no Cl/Br):**

HYCON products are Green products that compliant with RoHS directive and are Halogen free (Br/Cl<0.1%).

HY11P13

Embedded 18-Bit $\Sigma\Delta$ ADC

8-Bit RISC-like Mixed Signal Microcontroller

8. Package Information

8.1. LQFP64 (L064)

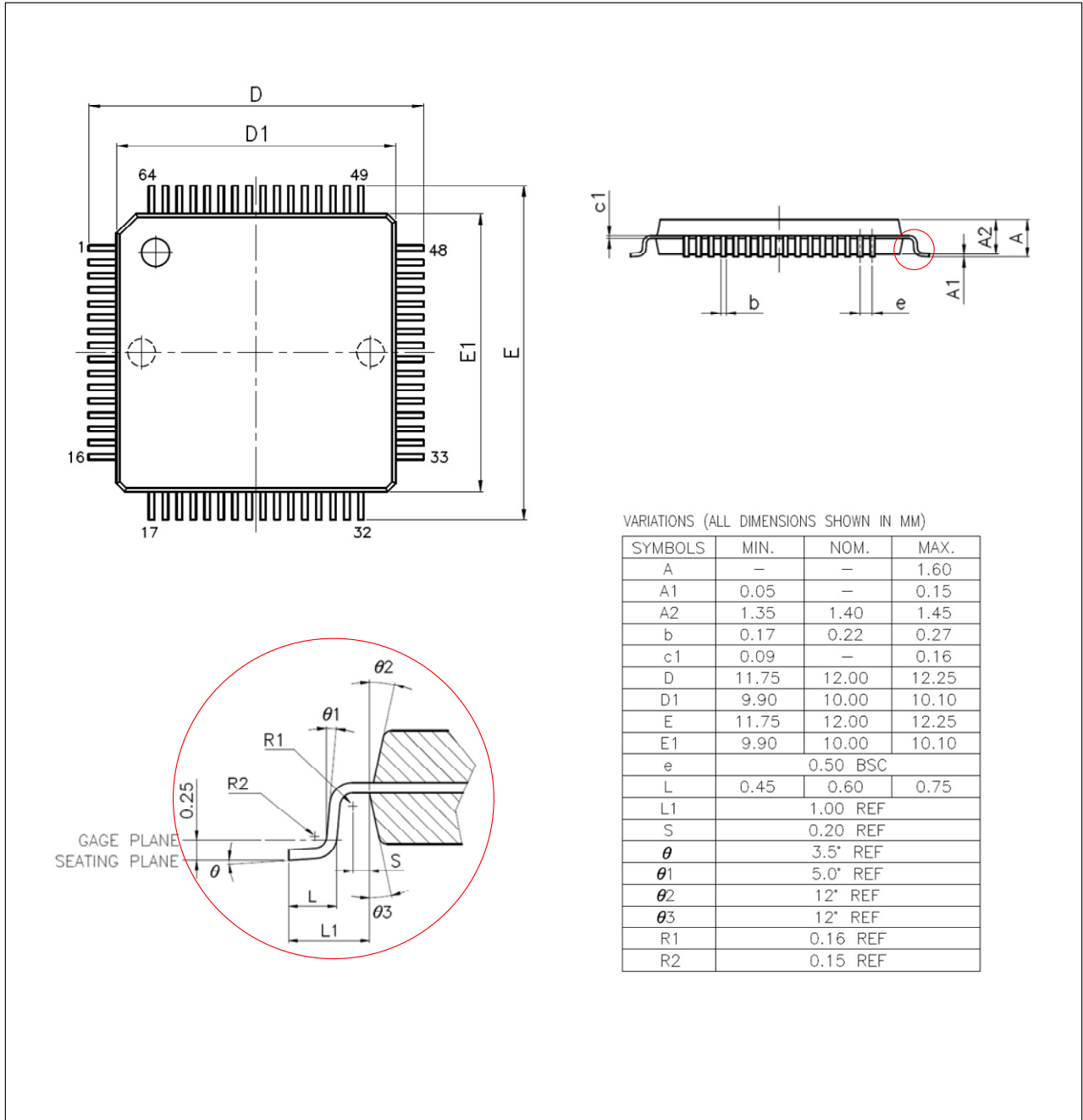

JEDEC MS-026 compliant

HY11P13

Embedded 18-Bit $\Sigma\Delta$ ADC

8-Bit RISC-like Mixed Signal Microcontroller

8.2. LQFP64(LS64)

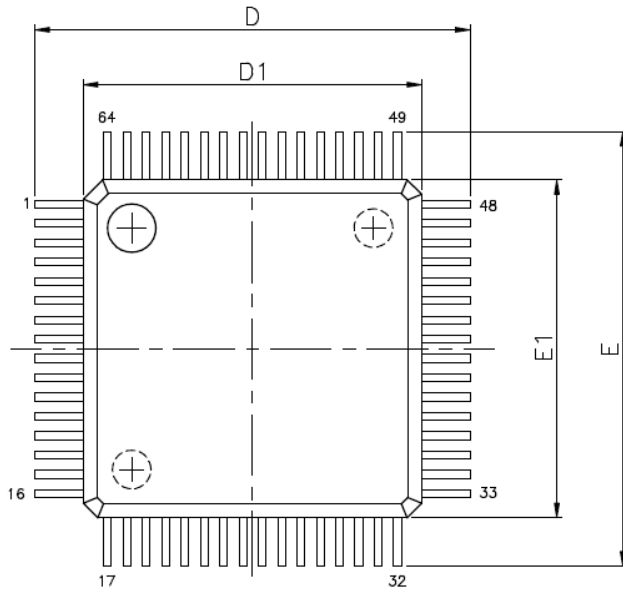

VARIATIONS (ALL DIMENSIONS SHOWN IN MM)

SYMBOLS	MIN.	NOM.	MAX.
A	—	—	1.60
A1	0.05	—	0.15
A2	1.35	1.40	1.45
b	0.13	0.18	0.23
c	0.09	—	0.20
D	9.00 BSC		
D1	7.00 BSC		
e	0.40 BSC		
E	9.00 BSC		
E1	7.00 BSC		
L	0.45	0.60	0.75
L1	1.00 REF		
θ	0°	3.5°	7°

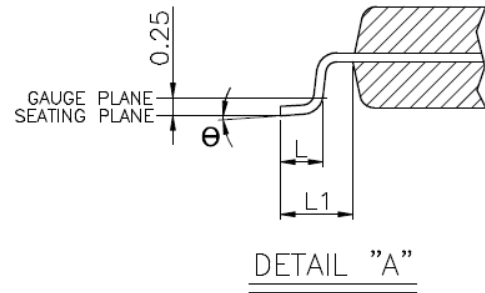
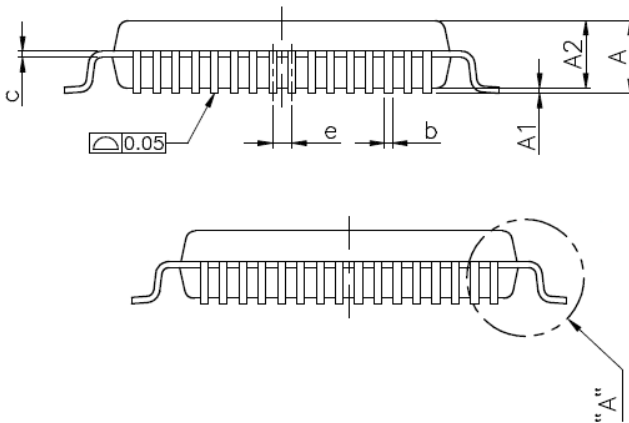

JEDEC MS-026 compliant

9. Revision Record

Major differences are stated thereafter:

Version	Page	Revision Summary
V04	ALL	First edition
V06		With reference to documentation: DS-HY11P13-V06_TC
	4	Features revision
	6~8	Table 2-1 Pin Definition and Function Description revision
	8~13	Chapter 3 Application Circuit revision
	24~25	Chapter 6.6 Power System revision
	26	Chapter 6.8 Low Noise OPAMP revision
	28~30	Chapter 6.9.2 SD18, Performance II revision
V07	15~16	Chapter 5 Register List revision
V08	4	Features revision
	9~10	Chapter 3.1 & 3.2 content revision
	24~25	Chapter 6.6 Power System revision
V09	1	Cover Revised
	5	Feature revised, delete 1/2bias description
	6	Add in Note 3 description
	10~14	Revised application circuit, added in RC circuit of RST
	15	Revised Internal Block Diagram
V13	4	Revise Chapter 1 content
	10	Revise Figure 3-2
	11	Revise Figure 3-3
	15	Revise Development Tool Related Operating Instruction serial numbers
	16	Add in SD18 Network chapter
	19	Revise Chapter 6
	26	Revise temp. drift spec of power system
	28	Reduce LCD current spec.
	34~35	Add in the chapter of SD18 Noise Performance
	36	Chapter 7 Ordering information revision
	38	Add in package information – 8.2 LQFP64(LS64)
V14	17	Added in 4.4 Low Noise OPAMP Network