



HY3118/HY3116

Datasheet

24-Bit Analog-to-Digital Convert

High Resolution $\Sigma\Delta$ ADC

With Rail-to-Rail OPAMP

Table of Contents

1. FEATURES	5
2. PRODUCT OVERVIEW.....	7
3. PIN DIAGRAM	8
3.1. I/O Pin Definition	8
3.1.1. SSOP package marker information	9
3.1.2. MSOP package marker information.....	9
4. APPLICATION CIRCUIT	10
4.1. Bridge Sensor	10
5. REGISTER LIST	11
5.1. Register List	11
5.2. Register Description.....	12
5.2.1. SYS Register - System configuration control register (8bit)	12
5.2.2. ADC1 Register - ADC configuration control register 1(8bit) (ADC input select).....	12
5.2.3. ADC2 Register - ADC configuration control register 2 (8bit)	13
5.2.4. ADC3 Register - ADC configuration control register 3(8bit)	14
5.2.5. ADC4 Register - ADC configuration control register 3(8bit)	14
5.2.6. ADO Register - ADC Output Code(24bit)	15
6. ELECTRICAL CHARACTERISTICS.....	16
6.1. Absolute Maximum Ratings	16
6.2. Electrical Characteristics.....	17
6.3. OPAMP, Electrical Specification.....	21
7. ENOB AND NOISE-FREE.....	22
8. I²C COMMUNICATION PROTOCOL	24

8.1. I2C Communication Sequence Diagram	24
9. OVERVIEW	31
9.1. Frequency vs. Low Power mode	31
9.2. VDDA Power (Low Dropout Regulator)	33
9.3. REFO Reference Voltage	33
9.4. Input Channel Multiplexer with IRQ	35
9.5. Reference Voltage and its Input Channel with VREF	36
9.6. Measurement Signal Input Channel with PGA	38
9.7. COMB Filter	41
9.8. Data Conversion Format.....	43
9.9. Rail-to-Rail OPAMP	44
10. ORDERING INFORMATION	45
11. PACKAGE INFORMATION.....	46
11.1. SSOP16	46
11.1.1. Package Dimensions	46
11.1.2. Tube Dimensions	47
11.1.3. Tape & Reel Information	48
11.2. MSOP10	50
11.2.1. Package Dimensions	50
11.2.2. Tape & Reel Information	51
12. REVISION RECORD.....	53

Notes:

1. Improvements and contents to this user guide necessitated by improvements to equipment may be made by Hycon Technology at any time and without notice. You may download the most up to date version of this user guide at <http://www.hycontek.com>.
2. Under no circumstances will Hycon Technology be liable in any way for third party copyright problems concerning graphs and application circuits contained in this user guide.
3. Hycon Technology guarantees that features, typical applications and functions of this product are compliant with this user guide when being used in stand-alone situation. Hycon Technology does not make the same guarantee when this product is used together with your finished goods or equipment. Hycon Technology advises you to conduct comprehensive evaluations and tests.
4. You, and not Hycon Technology, are responsible for making sure that the internal power consumption of IC is within limits given in this user guide by following the using conditions of input voltage, output voltage, and load current. Under no circumstances will Hycon Technology be liable in any way for damage caused by your using this product, even for a very short period of time, in conditions exceeding limits specified in this user guide.
5. In spite of embedded static protection circuit of this product Hycon Technology advises you do not apply static that is over protection circuit capacity.
6. Hycon Technology advises you not to use this product in mission critical circuits or components of mission critical circuits unless authorized with prior written permission. This may include, but not limited to, health and medical equipment, disaster prevention equipment, vehicles, automotive equipment, aviation equipment, and equipment and devices that may affect human body.
7. Hycon Technology strives to improve quality and reliability of this product. However every semiconductor will fail at certain probability and this may cause personal injury and/or fire. Hycon Technology advises you to pay special attention to redundancy and safety level in designing your end product. This may prevent incidents and accidents from happening.
8. Transfer and reproduction of part or all of the contents in this user guide in any format without the prior permission of Hycon Technology is prohibited.

HY3118/HY3116

24-Bit Analog-to-Digital Convert

High Resolution $\Sigma\Delta$ ADC

1. Features

- Sensor's pre-signal processing design
 - ◆ Equipped with 24-bit $\Sigma\Delta$ ADC analog to digital converter
 - ◆ Embedded Rail-to-rail OPAMP
 - ◆ Internal VDDA with sensor drive power output of up to 10mA
 - ◆ Switchable external crystal oscillator input and high precision internal RC oscillator operating clock
 - ◆ I2C digital transmission interface
- Operation environment
 - ◆ Digital voltage: 2.2V to 3.6V
 - ◆ Analog voltage: 2.4V to 3.6V
 - ◆ Operation current:
 1. Full speed: 1050uA (excluding OPAMP)
 2. Ultra-low sleep current: 1uA
 - ◆ Operation temperature range: -40°C to $+85^{\circ}\text{C}$

● Function block diagram

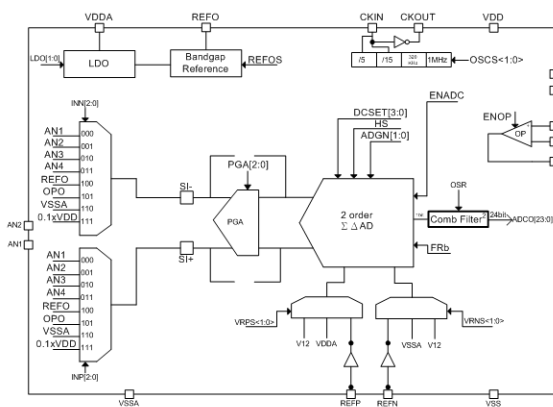

● 24-bits $\Sigma\Delta$ ADC

- ◆ Embedded programmable preamplifier (PGA) with optional gains of: $\times 1$, $\times 2$, $\times 4$, $\times 8$, $\times 16$, $\times 32$, $\times 64$, and $\times 128$.
- ◆ Optional data conversion output rate with upper limit of 7680SPs. 50/60Hz signal rejection at 10SPS data conversion output rate.

- ◆ Embedded DC bias voltage design that can produce bias voltage at VREF multiples of 0, $\pm 1/8$, $\pm 1/4$, $\pm 3/8$, $\pm 1/2$, $\pm 5/8$, $\pm 3/4$, and $\pm 7/8$
- ◆ RMS Noise:
 1. 100nV (Gain = 128) at 10 SPS output rate
 2. 37uV (Gain = 1) at 7680 SPS output rate
 3. 16 bit Noise-free resolution (Gain = 128 and VREF = 3.3V)
- ◆ Optional input buffer for reference voltage input
- ◆ IRQ function
- Rail-to-Rail OPAMP (HY3118 only)
 - ◆ Rail-to-rail signal input design
 - ◆ I/O current at 1mA
- Internal linear regulator VDDA and reference voltage REFO
 - ◆ Available VDDA output voltage: 2.4V, 2.7V, 3.0V or 3.3V
 - ◆ Available REFO output voltage: 1.2V or 1.5V
- I2C transmission interface:
 - ◆ Both standard and non-standard communication format
 - ◆ $F_{SCL} = 400\text{KHz}$
 - ◆ ADC IRQ function at non-standard mode
 - ◆ Sleep/Wake function (for register control)
- Application
 - ◆ Weight Scale
 - ◆ Strain Gauge
 - ◆ Pressure Scale
 - ◆ Industrial Process Control
- Package
 - ◆ SSOP16
 - ◆ MSOP10

HY3118/HY3116

24-Bit Analog-to-Digital Convert

High Resolution $\Sigma\Delta$ ADC



Model No.	Architecture	Input Channels	ENOB (Bits)	RMS Noise	System Clock	Sample Rate(Max)	Rail-to-Rail OPAMP	DC Offset Set	Interface	Package
HY3116	Sigma-Delta	2	20	100nV (10SPS)	Int. 327kHz/1Mhz	7680SPS	NO	4 bits	IIC	MSOP10
HY3118	Sigma-Delta	4	20	100nV (10SPS)	Int. 327kHz/1Mhz Ext.4.9152MHz	7680SPS	YES	4 bits	IIC	SSOP 16

2. Product Overview

HY3118/HY3116 is a high-precision, low-noise and low power 24-bit Analog-to-Digital converter (ADC) with embedded ultra-low-noise programmable preamplifier (PGA) featuring an effective number of bits at 21bit and 100nV sub-variable signal and less than 5 ppm/ $^{\circ}$ C temperature coefficient of gain for 128 folds of gains as well as two fully differential signal input channels, one fully differential reference voltage input channels, low-noise amplifier, reference voltage input buffer, signal input channel multiplex selector, 50/60 Hz noise interference suppressible design, and zero DC bias regulator for input signal.

In addition, this chip features VDDA voltage source of high-performance and programmable output voltage, low drift internal band gap reference, optional external clock input or internal RC oscillator clock serving as operating frequency, Rail-to-rail low-noise OPAMP and I2C communication interface.

This chip can run on internal RC or external oscillator. Data conversion rate of ADC ranges from 10SPS (50/60 Hz signal interference suppression) to 7680 SPS. Power consumption rate varies with data conversion rate. Standard operation current is 1050uA while sleep current smaller than 1uA. The chip's sleep and wake mechanism employs a special register controlled by I2C communication interface.

This products series are in package format of SSOP16 and MSOP10 for different functions.

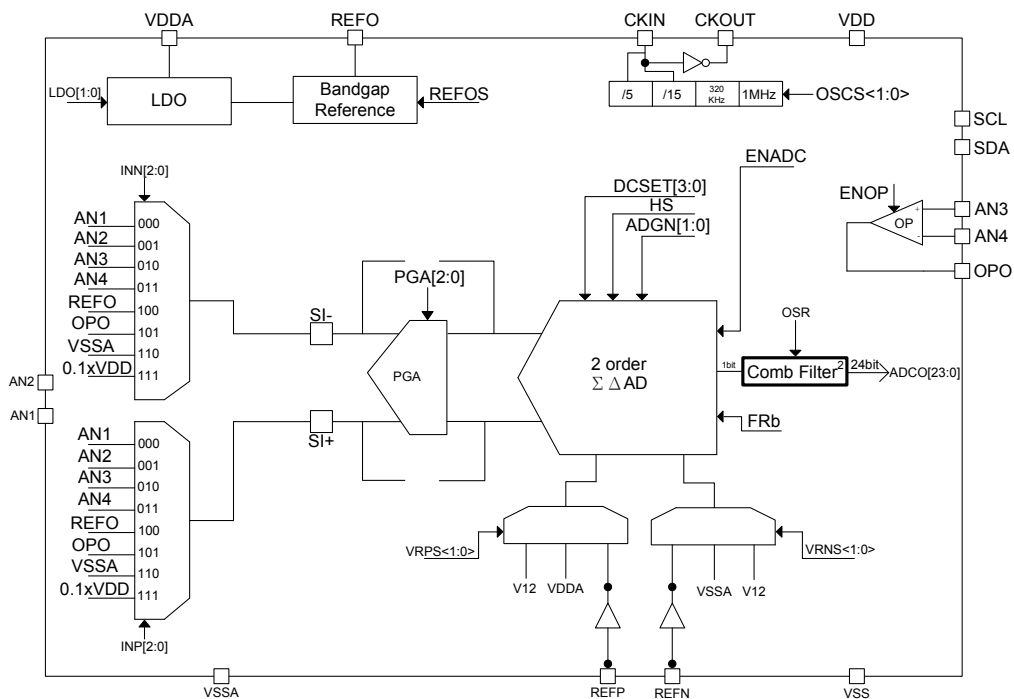

Figure 1 Function Block Diagram

3. Pin Diagram

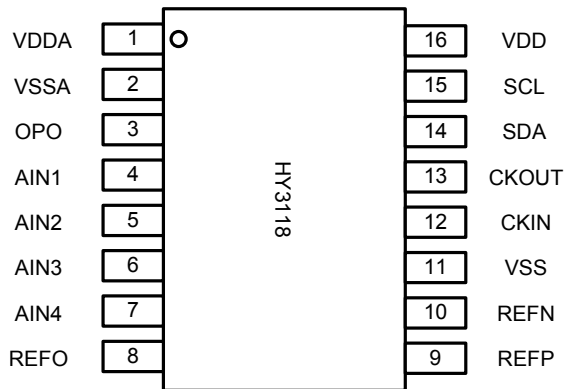

Figure 2 SSOP16 Pin Diagram

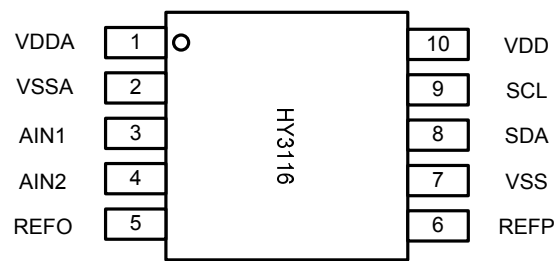

Figure 3 MSOP10 Pin Diagram

3.1. I/O Pin Definition

"I" input, "O" output, "S" Smith Trigger, "P" power supply, "A" analog channel

No.		Pin Name	Pin Characteristics		Function Description
SSOP16	MSOP10		Type	Buffer	
1	1	VDDA	P	P	Analog Power Supply: 2.4~3.6V
2	2	VSSA	P	P	Analog Ground
3	-	OPO	O	A	Operational Amplifier
4	3	AIN1	I	A	Analog Input1
5	4	AIN2	I	A	Analog Input2
6	-	AIN3	I	A	Analog Input3
7	-	AIN4	I	A	Analog Input4
8	5	REFO	O	A	Voltage Reference Output
9	6	REFP	I	A	Reference Input (Positive)
10	_* ¹	REFN	I	A	Reference Input (Negative)
11	7	VSS	P	P	Digital Ground
12	-	CKIN	I	A	ADC Clock Input
13	-	CKOUT	O	A	ADC Clock Output
14	8	SDA	I/O	S	I2C Data(Open-drain)
15	9	SCL	I/O	S	I2C CLK(Open-drain)
16	10	VDD	P	P	Digital Power Supply: 2.2~3.6V

*¹ REFN and VSS were connected when packaged in MSOP10 type.

Table 1 Pin Definition and Function Description

3.1.1. SSOP package marker information

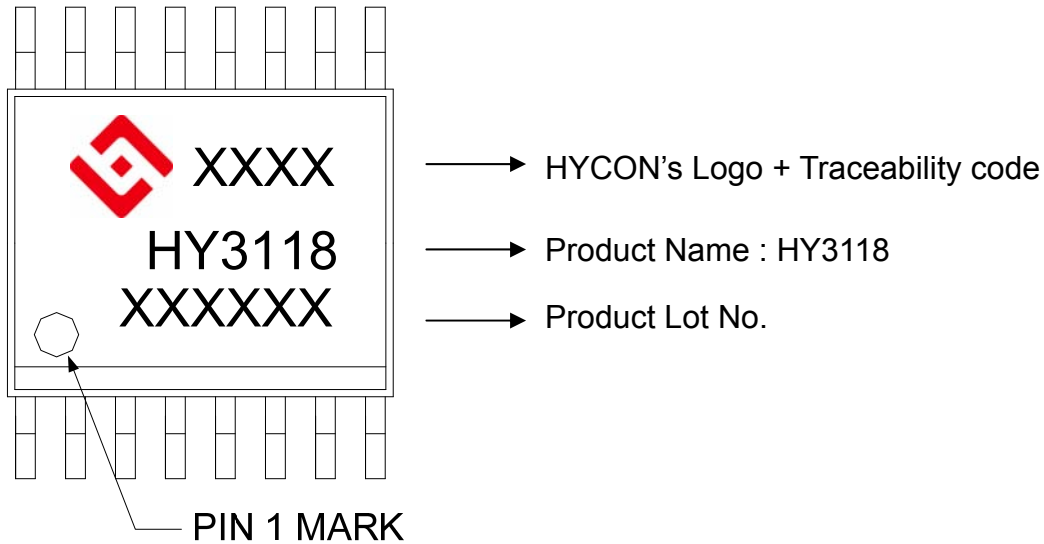

3.1.2. MSOP package marker information

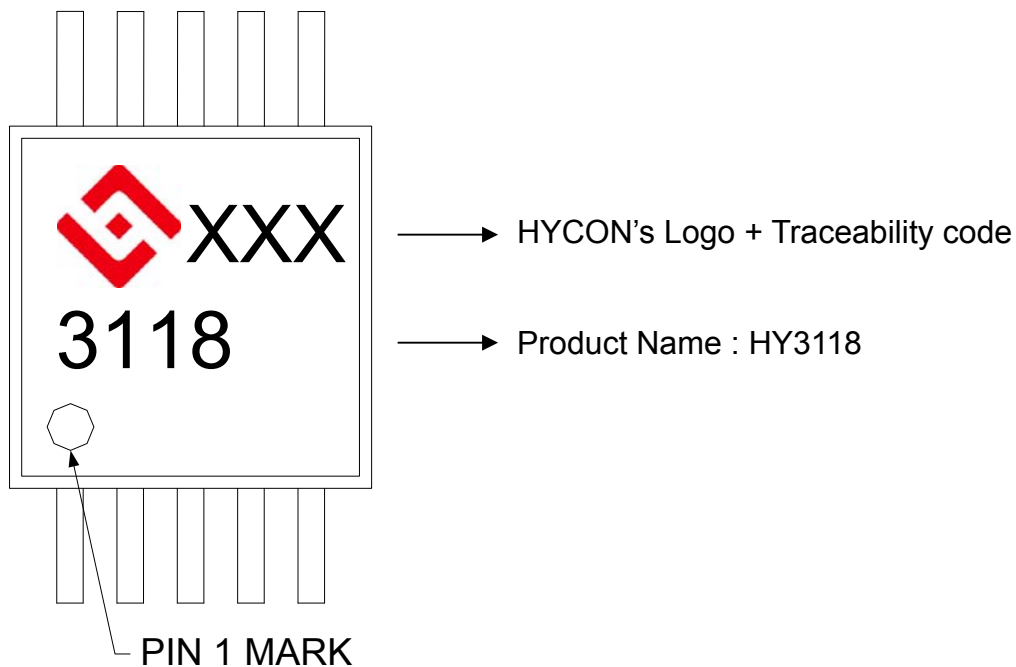

4. Application Circuit

4.1. Bridge Sensor

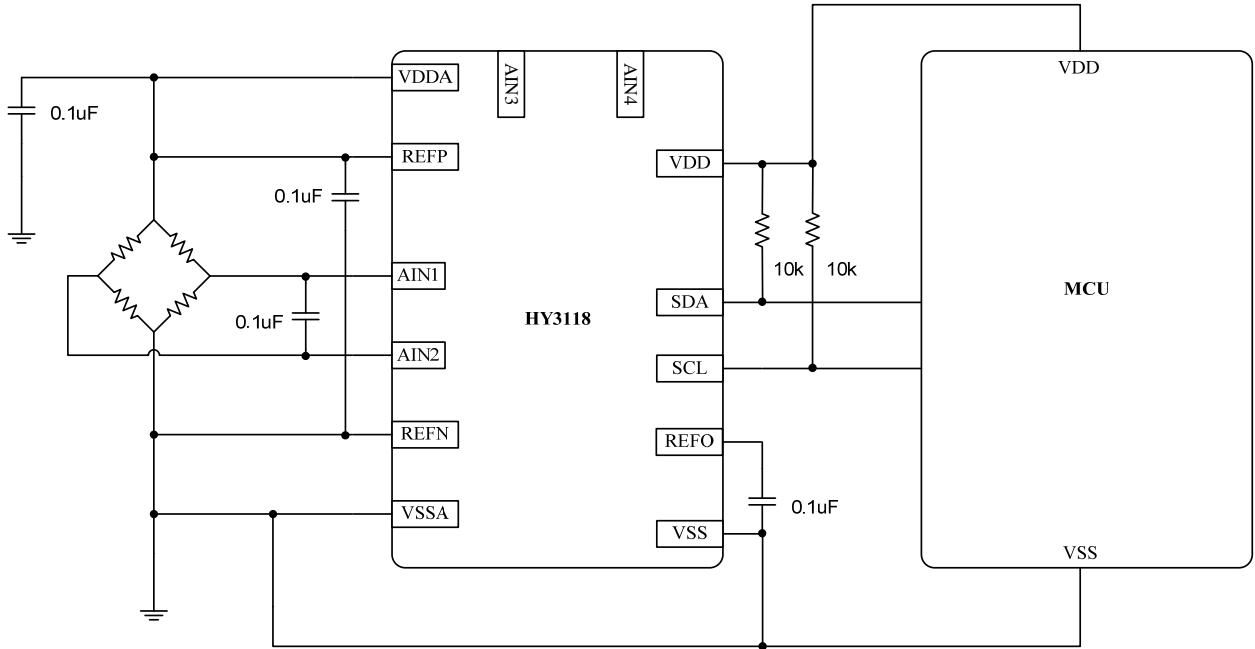

Figure 4 Application Circuit of Bridge Sensor

5. Register List

5.1. Register List

Register		Byte							
Address	Name	7	6	5	4	3	2	1	0
000h	SYS	-	APO	IRQEN	ENADC	ENLDO	ENREFO	ENOP	-
	Read/Write	-	R/W	R/W	R/W	R/W	R/W	R/W	-
	Initial Status	-	0	0	0	0	0	0	-
001h	ADC1	-	-	INP[2]	INP[1]	INP[0]	INN[2]	INN[1]	INN[0]
	Read/Write	-	-	R/W	R/W	R/W	R/W	R/W	R/W
	Initial Status	-	-	0	0	0	0	0	0
010h	ADC2	VRPS[1]	VRPS[0]	VRNS[1]	VRNS[0]	DCSET[3]	DCSET[2]	DCSET[1]	DCSET[0]
	Read/Write	R/W	R/W	R/W	R/W	R/W	R/W	R/W	R/W
	Initial Status	0	0	0	0	0	0	0	0
011h	ADC3	OSCS[1]	OSCS[0]	FRb	PGA[2]	PGA[1]	PGA[0]	ADGN[1]	ADGN[0]
	Read/Write	R/W	R/W	R/W	R/W	R/W	R/W	R/W	R/W
	Initial Status	0	0	0	0	0	0	0	0
100h	ADC4	LDO[1]	LDO[0]	REFO	HS	OSR[2]	OSR[1]	OSR[0]	-
	Read/Write	R/W	R/W	R/W	R/W	R/W	R/W	R/W	-
	Initial Status	0	0	0	0	0	0	0	-
101h	ADOH	ADOH<23:16>							
	Read/Write	R	R	R	R	R	R	R	R
	Initial Status	0	0	0	0	0	0	0	0
	ADOM	ADOM<15:8>							
	Read/Write	R	R	R	R	R	R	R	R
	Initial Status	0	0	0	0	0	0	0	0
	ADOL	ADOL<7:1>							
	Read/Write	R	R	R	R	R	R	R	R
	Initial Status	0	0	0	0	0	0	0	0

"-": unused, "R/W": read/write, "R": read only, "!" : keep as 0

Table 2 Register List

5.2. Register Description

5.2.1. SYS Register - System configuration control register (8bit)

Register		Byte							
Address	Name	7	6	5	4	3	2	1	0
000h	SYS	-	APO	IRQEN	ENADC	ENLDO	ENREFO	ENOP	-
	Read/Write	-	R/W	R/W	R/W	R/W	R/W	R/W	-
	Initial Status	-	0	0	0	0	0	0	-

Table 3 SYS Register

APO[0] Auto Power off

<0> Disable
 <1> Enable

ENLDO[0] Enable LDO control

<0> Disable
 <1> Enable

IRQEN[0] SDA interrupt function

<0> Disable SDA interrupt function
 <1> Enable SDA interrupt function

ENREFO[0] Enable REFO control

<0> Disable
 <1> Enable

ENADC[0] ADC control

<0> Disable
 <1> Enable

ENOP[0] Enable rail-to-rail OPAMP

<0> Disable
 <1> Enable

5.2.2. ADC1 Register - ADC configuration control register 1(8bit) (ADC input select)

Register		Byte							
Address	Name	7	6	5	4	3	2	1	0
001h	ADC1	-	-	INN[2]	INN[1]	INN[0]	INP[2]	INP [1]	INP [0]
	Read/Write	-	-	R/W	R/W	R/W	R/W	R/W	R/W
	Initial Status	-	-	0	0	0	0	0	0

Table 4 ADC1 Register

INN[2:0] Negative input voltage selection

<000> AIN1
 <001> AIN2
 <010> AIN3
 <011> AIN4
 <100> REFO
 <101> OPO
 <110> VSSA
 <111> 0.1xVDD

INP[2:0] Positive input voltage selection

<000> AIN1
 <001> AIN2
 <010> AIN3
 <011> AIN4
 <100> REFO
 <101> OPO
 <110> VSSA
 <111> 0.1xVDD

5.2.3. ADC2 Register - ADC configuration control register 2 (8bit)

Register		Byte							
Address	Name	7	6	5	4	3	2	1	0
010h	ADC2	VRPS[1]	VRPS[0]	VRNS[1]	VRNS[0]	DCSET[3]	DCSET[2]	DCSET[1]	DCSET[0]
	Read/Write	R/W	R/W	R/W	R/W	R/W	R/W	R/W	R/W
	Initial Status	0	0	0	0	0	0	0	0

Table 5 ADC2 Register

VRPS[1:0] Positive reference voltage selection

- <00> Vrefp (Unbuffered)
- <01> VDDA
- <10> Vrefp (buffered)
- <11> Internal reference voltage V12

VRNS[1:0] Negative reference voltage selection

- <00> Vrefn (Unbuffered)
- <01> VSSA
- <10> Vrefn (buffered)
- <11> Internal reference voltage V12

DCSET[3:0] DC offset input voltage selection

(VREF = REFP-REFN)

- <0000> 0 VREF
- <0001> +1/8 VREF
- <0010> +1/4 VREF
- <0011> +3/8 VREF
- <0100> +1/2 VREF
- <0101> +5/8 VREF
- <0110> +3/4 VREF
- <0111> +7/8 VREF
- <1000> 0 VREF
- <1001> -1/8 VREF
- <1010> -1/4 VREF
- <1011> -3/8 VREF
- <1100> -1/2 VREF
- <1101> -5/8 VREF
- <1110> -3/4 VREF
- <1111> -7/8 VREF

HY3118/HY3116

24-Bit Analog-to-Digital Convert

High Resolution Σ ADC



5.2.4. ADC3 Register - ADC configuration control register 3(8bit)

Register		Byte							
Address	Name	7	6	5	4	3	2	1	0
011h	ADC3	OSCS[1]	OSCS[0]	FRb	PGA[2]	PGA[1]	PGA[0]	ADGN[1]	ADGN[0]
	Read/Write	R/W	R/W	R/W	R/W	R/W	R/W	R/W	R/W
	Initial Status	0	0	0	0	0	0	0	0

Table 6 ADC3 Register

OSCS[1:0] Oscillator source select

- <00> Internal oscillator 327KHz
- <01> Internal oscillator 1000KHz
- <10> External oscillator divider by 15
- <11> External oscillator divider by 5

FRb [0] Full reference range select

- <0> Full reference range input
- <1> 1/2 reference range input

PGA[2:0] Input signal gain for modulator

- <000> PGA Disable
- <001> Gain = 8
- <010> Reservations
- <011> Gain = 16
- <100> Reservations
- <101> Reservations
- <110> Reservations
- <111> Gain = 32

ADGN[1:0] Input signal gain for modulator

- <00> Gain = 1
- <01> Gain = 2
- <10> Reservations
- <11> Gain = 4

5.2.5. ADC4 Register - ADC configuration control register 3(8bit)

Register		Byte							
Address	Name	7	6	5	4	3	2	1	0
100h	ADC4	LDO[1]	LDO[0]	REFO	HS	OSR[2]	OSR[1]	OSR[0]	-
	Read/Write	R/W	R/W	R/W	R/W	R/W	R/W	R/W	-
	Initial Status	0	0	0	0	0	0	0	-

Table 7 ADC4 Register

LDO[1:0] LDO output voltage selection

- <00> 3.3V
- <01> 3.0V
- <10> 2.7V
- <11> 2.4V

REFO[0] Reference voltage selection

- <0> REFO= 1.2V
- <1> REFO = 1.5V

HS[0] High conversion rate

- <0> Slow sampling rate (327KHz)
- <1> High sampling rate (1000K Hz)

OSR[2:0] ADC output rate select

- <000> 2560sps / 7680sps (128)
- <001> 1280sps / 3840sps (256)
- <010> 640sps / 1920sps (512)
- <011> 320sps / 960sps (1024)
- <100> 160sps / 480sps (2048)
- <101> 80sps / 240sps (4096)
- <110> 40sps / 120sps (8192)
- <111> 10sps / 30sps (32768)

HY3118/HY3116

24-Bit Analog-to-Digital Convert

High Resolution $\Sigma\Delta$ ADC



5.2.6. ADO Register - ADC Output Code(24bit)

Register		Byte							
Address	Name	7	6	5	4	3	2	1	0
101h	ADOH	ADOH<23:16>							
	Read/Write	R	R	R	R	R	R	R	R
	Initial Status	0	0	0	0	0	0	0	0
	ADOM	ADOM<15:8>							
	Read/Write	R	R	R	R	R	R	R	R
	Initial Status	0	0	0	0	0	0	0	0
	ADOL	ADOL<7:1>							ADST
	Read/Write	R	R	R	R	R	R	R	R
	Initial Status	0	0	0	0	0	0	0	0

Table 8 ADO Register

ADO[23:1] ADC output Code

ADOH[7:0] ADC output Code of ADO[23:16]

ADOM[7:0] ADC output Code of ADO[15:8]

ADOL[7:1] ADC output Code of ADO[7:1]

ADST[0] ADC output Code Status

<0> Information has been read

<1> Information is not read

6. Electrical Characteristics

6.1. Absolute Maximum Ratings

Description	HY3118/HY3116	UNIT
VDD to VSS	-0.3 to +3.6	V
VDD to VSSA	-0.3 to +3.6	V
VSSA to VSS	-0.3 to +0.3	V
Input Current	100, Momentary	mA
	10, Continuous	mA
Analog Input Voltage to VSSA	-0.3 to VDDA + 0.3	V
Digital Input Voltage to VSS	-0.3 to VDD + 0.3	V
Maximum Junction Temperature	+150	°C
Operating Temperature Range	-40 to +85	°C
Storage Temperature Range	-60 to +150	°C

Table 9a Electrical Characteristics

HY3118/HY3116

24-Bit Analog-to-Digital Convert

High Resolution Σ ADC

6.2. Electrical Characteristics

All specifications at $T_A = -40^{\circ}\text{C}$ to $+85^{\circ}\text{C}$, $V_{DDA} = V_{DD} = \text{REFP} = +3\text{V}$, $\text{REFN} = \text{VSSA}$, and $\text{PGA} \times \text{Gain} = 128$, unless otherwise noted.					
PARAMETER	CONDITIONS	HY3118/HY3116			UNIT
		MIN	TYP	MAX	
Analog Inputs					
Full-Scale Input Voltage ($V_{\text{INP}} - V_{\text{INN}}$)	$V_{\text{REF}} = V_{\text{DDA}}$,	$\pm 0.5 \times V_{\text{REF}} / (\text{PGA} \times \text{Gain})$			V
Full-Scale Input Voltage ($V_{\text{INP}} - V_{\text{INN}}$)	$V_{\text{DDA}} = 3.3\text{V}$, $V_{\text{REF}} = 1\text{V}$,	$\pm 0.9 \times V_{\text{REF}} / (\text{PGA} \times \text{Gain})$			V
Negative Signal Input (V_{INN})		$V_{\text{SSA}} - 0.1$		V_{DDA}	V
Positive Signal Input (V_{INP})		$V_{\text{SSA}} - 0.1$		V_{DDA}	V
Common-Mode Input Range		$V_{\text{SSA}} - 0.1$		V_{DDA}	V
System Performance					
Resolution	No Missing Codes	23			Bits
Data Rate	Internal oscillator 1000KHz, OSR=32768, HS[0]=1b	30			SPS
	Internal oscillator 327KHz, OSR=32768, HS[0]=0b	10			SPS
	External Oscillator ⁽¹⁾ , HS[0]=1b, Speed=High	$f_{\text{CLK}} / 61440$			SPS
	External Oscillator ⁽¹⁾ , HS[0]=0b, Speed=Low	$f_{\text{CLK}} / 491520$			SPS
Digital Filter Settling Time	Full Settling	4			Conversions
Integral Nonlinearity (INL)	Differential Input, End-Point Fit, $G = 1$, $V_{\text{IN}} = 0.9 \times V_{\text{R}}$, $\Delta V_{\text{R}} \sim 1.2\text{V}$		± 30	± 100	ppm
Input Offset Error	Gain=1,		± 50		ppm of FS
	Gain=128,		± 3		ppm of FS
Input Offset Drift	Gain=1		2		$\mu\text{V}/^{\circ}\text{C}$
	Gain=128,		20		$\text{nV}/^{\circ}\text{C}$
Gain Drift	Reference Buffer off, Input common voltage= $V_{\text{DDA}}/2$		5		ppm/ $^{\circ}\text{C}$
	Reference Buffer on, Input common voltage= $V_{\text{DDA}}/2$		50		
Normal-Mode Rejection	$f_{\text{IN}} = 50\text{Hz}$ or 60Hz	Internal Oscillator	90		dB
	$\pm 1\text{Hz}$, $f_{\text{DATA}} = 10\text{SPS}$	External Oscillator ⁽¹⁾	90		dB

HY3118/HY3116

24-Bit Analog-to-Digital Convert

High Resolution $\Sigma\Delta$ ADC

Common-Mode Rejection	at DC, Input Voltage=VDDA/2± 0.1V		75	dB
Input-Referred Noise	fDATA = 10SPS , Gain=128,		100	nV, rms
	fDATA = 7680SPS , Gain=1,		3700	nV, rms
Power-Supply Rejection	at DC,VDDA=3V±0.1V, Gain=1		60	dB
	at DC,VDDA=3V±0.1V, Gain=128		95	dB
Voltage Reference Input				
Voltage Reference Input (VREF)	VREF = REFP – REFN		VDDA	V
Negative Reference Input (REFN)		VSS-0.1	VDDA/2	V
Positive Reference Input (REFP)		VDDA/2	VDDA+0.1	V
Voltage Reference Input Current	Input buffer on		10	nA
Power System				
VDDA operation current	I _L = 0mA, ENLDO[0]=1b, LDO[1:0]=00b		45	uA
VDDA output voltage	I _L = 0.1mA, ENLDO[0]=1b, VDD ≥ VDDA+0.2V	LDO[1:0]=00b	3.3	V
		LDO[1:0]=01b	3.0	V
		LDO[1:0]=10b	2.7	V
		LDO[1:0]=11b	2.4	V
VDDA Dropout voltage	I _L = 10mA, ENLDO[0]=1b,	LDO[1:0]=00b	130	mV
		LDO[1:0]=01b	140	mV
		LDO[1:0]=10b	155	mV
		LDO[1:0]=11b	175	mV
VDDA temperature drift	I _L = 0.1mA, ENLDO[0]=1b, LDO[1:0]=11b	T _A =-40°C~85°C	50	PPM/°C
VDDA voltage drift	I _L = 0.1mA, ENLDO[0]=1b, LDO[1:0]=11b	VDD=2.5V~3.6V	±0.2	%/V
REFO operation current	I _L = 0mA, ENREFO[0]=1b, REFO[0]=1b		45	uA
REFO output voltage, V _{REFO}	I _L = 10uA, ENREFO[0]=1b	REFO[0]=0b	1.2	V
		REFO[0]=1b	1.5	V
REFO output voltage with load	I _L = ±200uA, ENREFO[0]=1b		0.98	1.02
REFO temperature drift	I _L = 10uA,	T _A =-40°C~85°C	50	PPM/°C

HY3118/HY3116

24-Bit Analog-to-Digital Convert

High Resolution $\Sigma\Delta$ ADC

	ENREFO[0]=1b					
REFO voltage drift	$I_L = 10\mu A$, ENREFO[0]=1b	VDDA=2.4V~3.6V	100		$\mu V/V$	
Internal RC Oscillator						
Low speed oscillator frequency	Internal oscillator, 327KHz, TA=25°C		290	327	360	KHz
Low speed oscillator Voltage drift	VDD=2.2V~3.6V		0.5			%
Low speed oscillator temperature drift	TA=-40°C~85°C		2			%
High speed oscillator frequency	Internal oscillator, 1000KHz, TA=25°C		900	1000	1100	KHz
High speed oscillator Voltage drift	VDD=2.2V~3.6V		1			%
High speed oscillator temperature drift	TA=-40°C~85°C		2			%
Digital						
Logic Levels	VIH	Digital inputs_SCL	0.7 VDD	VDD + 0.1		V
		Digital inputs_S	0.7 VDD	3.7		V
	VIL		VSS	0.2 VSS		V
	VOH	IOH = 1mA	VDD - 0.4			V
	VOL	IOL = 1mA			0.2 VDD	V
Input Leakage	0 < VIN < VDD		0.1			nA
External Clock Input Frequency (f _{CLKIN})			4.9152			MHz
Serial Clock Input Frequency (f _{SCLK})					5	MHz
(1). HY3116 does not support external oscillator function.						

Table 9b Electrical Characteristics

HY3118/HY3116

24-Bit Analog-to-Digital Convert

High Resolution $\Sigma\Delta$ ADC

All specifications at VDD=3.6V, internal VDDA, Internal Oscillator enable, unless otherwise noted.					
PARAMETER	CONDITIONS	HY3118/HY3116			UNIT
		MIN	TYP	MAX	
Power Supply					
Power-Supply Voltage (VDDA, VDD)		2.4		3.6	V
Analog Supply Current I, Internal oscillator 327KHz, OSR=32768, HS[0]=0b, fDATA = 10SPS	VDDA=2.4V, Gain=1		180		μ A
	VDDA=2.4V, Gain=128		530		μ A
	VDDA=3.0V, Gain=1		260		μ A
	VDDA=3.0V, Gain=128		550		μ A
	VDDA=3.3V, Gain=1		270		μ A
	VDDA=3.3V, Gain=128		570		μ A
	Reference input buffer (VRPS[1:0]=VRNS[1:0]=10b)			30	
Analog Supply Current II, Internal oscillator 1000KHz, OSR=32768, HS[0]=1b, fDATA = 30SPS	VDDA=2.4V, Gain=1		440		μ A
	VDDA=2.4V, Gain=128		1110		μ A
	VDDA=3.0V, Gain=1		450		μ A
	VDDA=3.0V, Gain=128		1150		μ A
	VDDA=3.3V, Gain=1		460		μ A
	VDDA=3.3V, Gain=128		1180		μ A
Analog Supply Current III, External Oscillator 4.9152MHz, OSR=32768, HS[0]=0b, fDATA = 10SPS	VDDA=2.4V, Gain=1		270		μ A
	VDDA=2.4V, Gain=128		630		μ A
	VDDA=3.0V, Gain=1		276		μ A
	VDDA=3.0V, Gain=128		650		μ A
	VDDA=3.3V, Gain=1		280		μ A
	VDDA=3.3V, Gain=128		670		μ A
Analog Supply Current IV, External Oscillator 4.9152MHz, OSR=32768, HS[0]=1b, fDATA = 30SPS	VDDA=2.4V, Gain=1		520		μ A
	VDDA=2.4V, Gain=128		1150		μ A
	VDDA=3.0V, Gain=1		560		μ A
	VDDA=3.0V, Gain=128		1215		μ A
	VDDA=3.3V, Gain=1		570		μ A
	VDDA=3.3V, Gain=128		1240		μ A
Power down current	ENLDO[0]=ENADC[0]= ENOP[0]=0b,	VDD = 2.4V	0.6		μ A
		VDD = 3.6V	0.75		μ A

Table 9c Electrical Characteristics

HY3118/HY3116

24-Bit Analog-to-Digital Convert

High Resolution $\Sigma\Delta$ ADC

6.3. OPAMP, Electrical Specification

All specifications at VDD=3V, internal VDDA, Internal Oscillator enable, unless otherwise noted.

Sym.	Parameter	Test Conditions	Min.	Typ.	Max.	unit
VDDA	Power supply		2.4		3.6	v
V _{OUT}	Output range		0		VDDA	v
VINC	Input common range		0		VDDA	v
I _{OA}	OA current	Each OA		70		μ A
I _{OA_LOAD}	Output current loading (push or pull)	VDDA = 3.0V, 0.3V < Output voltage < VDDA-0.3V			1	mA
		VDDA = 2.4V, 0.3V < Output voltage < VDDA-0.3V			0.5	mA
C _{LOAD}	Max output capacitor load				1000	pF
R _{FB}	Reference input resistance			5K		Ω
R _{SW}	Switch turn on resistance				300	Ω
SR	ADC input clock	Loading R=10K, C=100pF		0.6		V/ms
G _{OPEN}	Open loop gain	Loading C=100pF		100		dB
UGB	Unit gain bandwidth	Loading C=100pF		1000		KHz
PM	Phase margin	Loading C=100pF		68		Deg
GM	Gain margin			18		dB
NVIN	AINx Input refer	Vin= 1.2V, 1KHz		220		nV/ \sqrt Hz
	noise	Vin= 1.2V, 10KHz		75		nV/ \sqrt Hz
V _{OS}	Offset error				\pm 25	mV
PSRR	Power supply rejection ratio	Vout=1.2V, Δ VDD = 100mV, at DC		70		dB
CMRR	Common mode rejection ratio	Vout=1.2V, Δ VIN= 100mV, at DC		70		dB

HY3118/HY3116

24-Bit Analog-to-Digital Convert

High Resolution $\Sigma\Delta$ ADC

7. ENOB and Noise-Free

Table 10 points out the relations between typical noise performance, gain and data rate. Test conditions are configured as DD=3.3V, VDDA=3.0V, difference of reference voltage of ADC=VDDA/2, ADC equivalent input impedance=1K load cell short and sampling 1024 data records.

$\Sigma\Delta$ ADC Noise Performance with Output rate/GAIN at VDDA=3.0V, VREF=1.5V										
Output rate (sps)	Max. Vin(mV) =0.9*VREF ⁽¹⁾	Gain	=	PGA	x	ADGN	ENOB (RMS Bit)	RMS Noise (nV)	Noise Free (Bit)	PEAK-TO-PEAK Noise (nV)
10	± 1350	1	=	1	x	1	20.26	2389	17.54	15699
	± 675	2	=	1	x	2	20.20	1246	17.56	7810
	± 338	4	=	1	x	4	20.05	690	17.33	4594
	± 169	8	=	8	x	1	20.04	347	17.29	2345
	± 42	32	=	32	x	1	19.59	120	16.80	829
	± 21	64	=	32	x	2	18.79	105	16.00	729
80	± 1350	1	=	1	x	1	18.72	100	15.23	619
	± 675	2	=	1	x	2	18.70	7045	15.96	47382
	± 338	4	=	1	x	4	18.73	3439	16.02	22550
	± 169	8	=	8	x	1	18.54	1960	15.92	12163
	± 42	32	=	32	x	1	18.50	1009	15.81	6518
	± 21	64	=	32	x	2	18.19	312	15.47	2069
2560	± 1350	1	=	1	x	1	17.42	267	14.78	1665
	± 675	2	=	1	x	2	16.55	245	13.89	1554
	± 338	4	=	1	x	4	16.22	39153	13.48	262213
	± 169	8	=	8	x	1	16.11	21075	13.38	140432
	± 42	32	=	32	x	1	15.99	11539	13.30	74202
	± 21	64	=	32	x	2	16.01	5664	13.25	38456
7680	± 1350	1	=	1	x	1	15.66	1810	12.93	12057
	± 675	2	=	1	x	2	14.95	1474	12.23	9772
	± 338	4	=	1	x	4	14.08	1352	11.40	8694
	± 169	8	=	8	x	1	16.31	36854	13.57	247636
	± 42	32	=	32	x	1	16.18	20172	13.51	128579
	± 21	64	=	32	x	2	16.07	10915	13.31	73940
7680	± 1350	1	=	1	x	1	16.10	5332	13.36	35838
	± 675	2	=	1	x	2	15.76	1685	12.95	11822
	± 338	4	=	1	x	4	15.01	1416	12.27	9466
	± 169	8	=	8	x	1	14.07	1363	11.35	8969
	± 42	32	=	32	x	1				
	± 21	64	=	32	x	2				

(1) Max.Vin (mV) is the max. input voltage of single end to analog ground (AVSS).

Table 10 $\Sigma\Delta$ ADC Noise Performance Table

HY3118/HY3116

24-Bit Analog-to-Digital Convert

High Resolution Σ ADC

The RMS Noise and Peak-to-Peak noise are referred to the noise generated from the chip itself at the input end. RMS Noise is ADC input noise and the Peak-to-Peak noise referring in this spec is the deviation of maximum and minimum noise of 1000 records (± 3.3 standard deviation).

$$ENOB = \frac{In \frac{FSR}{RMS\ Noise}}{In_2}$$

$$Noise - Free\ Bits = \frac{In \frac{FSR}{Peak-to-Peak\ Noise}}{In_2}$$

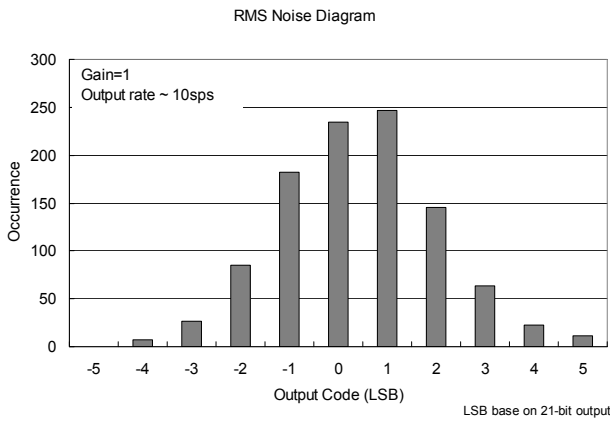

Figure 5 RMS Noise Diagram

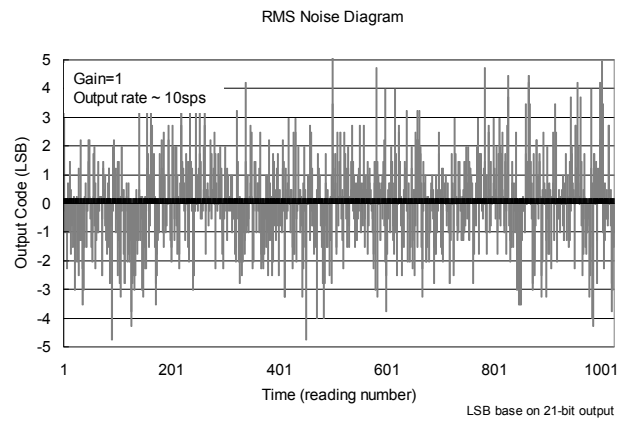

Figure 6 Output Code Diagram

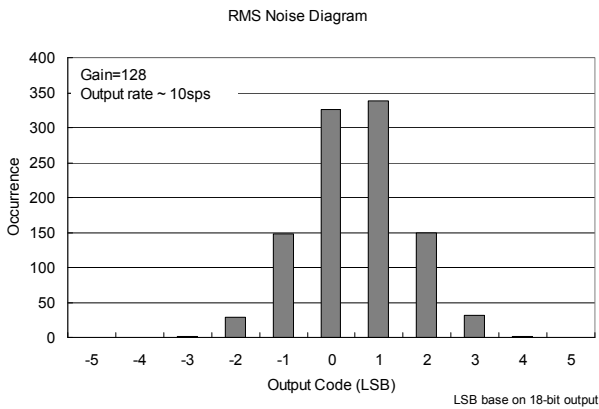

Figure 7 RMS Noise Diagram

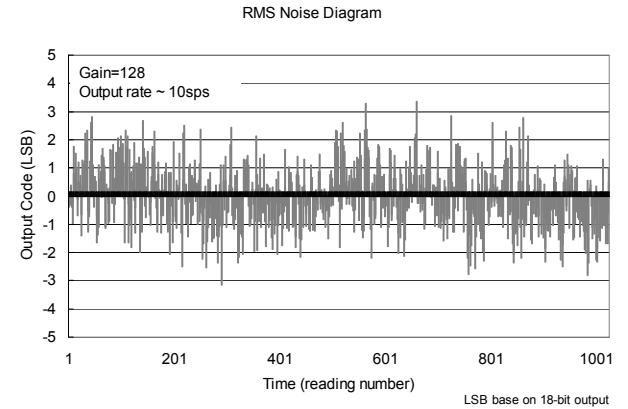

Figure 8 Output Code Diagram

8. I²C Communication Protocol

- ADC IRQ vector support
- Dual lines communication interface
- $f_{SCL} = 400\text{KHz}$
- Address definition: 0xA0h
- Low power consumption communication interface

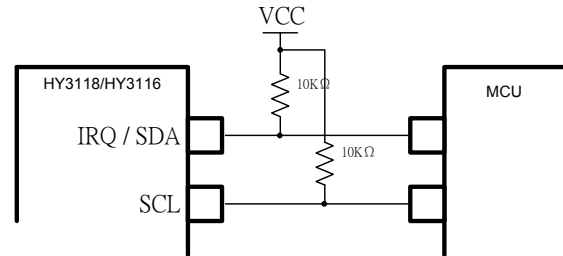

Figure 9 Communication Interface
Connection Diagram

Chip's communication mechanism employs flexible I²C structure that allows with- or without-IRQ notice after completion of ADC conversion for different applications. In case of communication protocol without IRQ notice the time for retrieving the end of ADC conversion must be measured by users manually. For protocol with IRQ notice, an IRQ pulse signal will be given after ADC conversion.

IRQ pulse signal is generated by I²C's SDA communication PIN. When set at this mode the SDA pin is at high potential caused by external pull-up resistor after end of data transmission and generates a low potential pulse signal after ADC conversion as a notice to chip users. Current consumption for SDA at low potential is measured by pull-up resistance and VCC voltage.

In an IRQ not initiated mode, users determine whether the ADC output data has been read by reading the status data of the ADO [ADST] buffer and the ADO [ADST] status will update at the time of ADO buffer reading. As a result, when IRQ is inactive the ADC output data and the ADO [ADST] status remain intact when the ADC interrupts at the time of ADO buffer reading.

Chip address is fixed at 0xA0h, that is, device address [6:0] = 1010000b.

8.1. I²C Communication Sequence Diagram

I²C communication format of HY3118/HY3116 are illustrated below:

- a. Data Validity Definition
- b. Start and Stop Definition
- c. ACK Definition
- d. IRQ Definition
- e. Wave Definition
- f. Write Register
- g. Read Register
- h. Reread Register

HY3118/HY3116

24-Bit Analog-to-Digital Convert

High Resolution $\Sigma\Delta$ ADC

- i. Write Register then Read Register
- j. IRQ Read Register
- k. Call Chip Reset

有效資料定義 (Data Validity Definition)

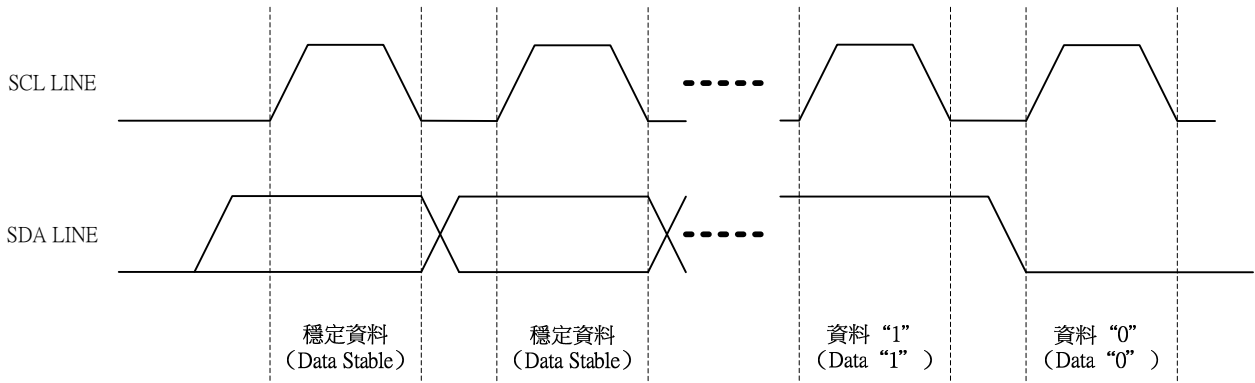

Figure 10 Valid Data Wave Form of Communication I²C

開始與停止定義 (Start and Stop Definition)

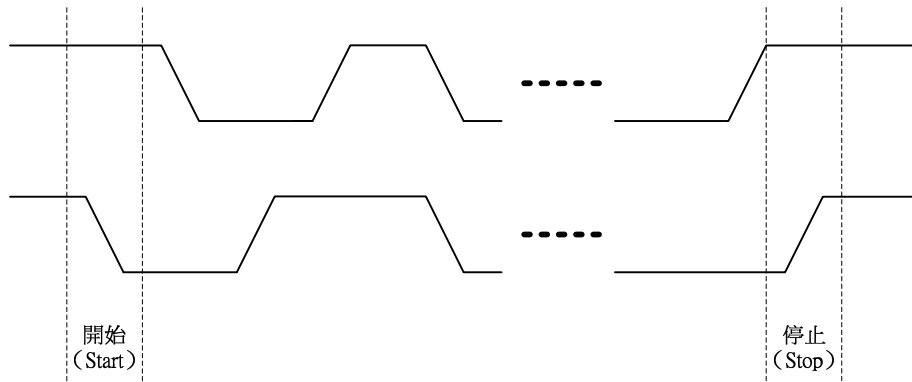
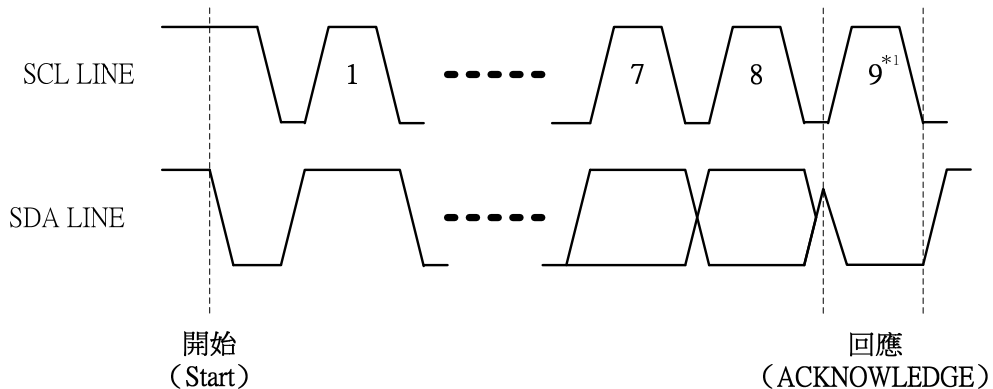

Figure 11 Start and End Wave Form of Communication I²C

ACK 回應信號定義 (ACK Definition)



*1 When the 8th-clocking SCL signal is sent from the mater to the slave end, the master's SDA pin must change from output to input status for receiving the ACK signal sent by the slave end.
 When the slave end is set up with ADC IRQ interruption signal, the master's SDA pin must set to input status for receiving the IRQ low potential pulse signal sent by the slave end.

Figure 12 ACK Wave Form of Communication I²C

MACK 傳送信號定義 (MACK Definition)

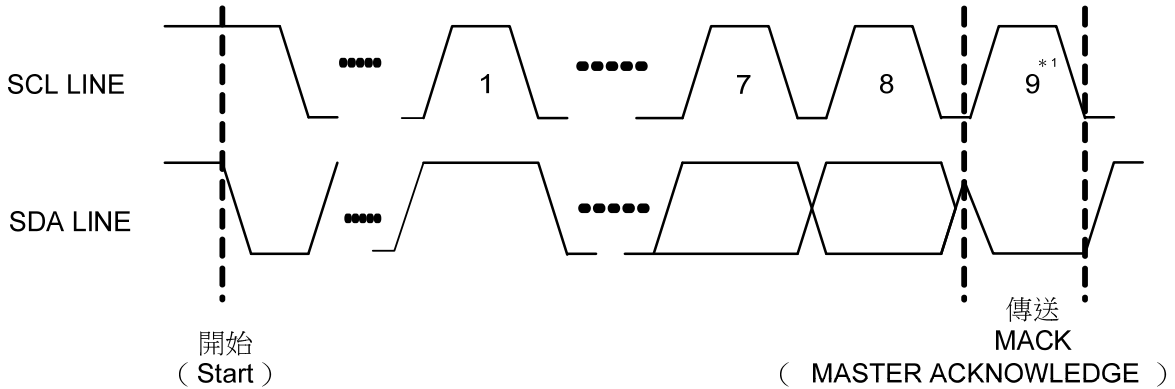

*1 MACK occurred when read in values at word address 05h (ADO) and continually read 3 bytes of data output. Before Data 2/Data 3 are outputted, SDA pin must be set to output pin by Master end and set output to low before the 9th-clocking rising edge then notice Slave end so that Data 2/Data 3 can be outputted continually.

Figure 13 MACK Wave Form of Communication I²C

IRQ 中斷信號定義 (IRQ Definition)

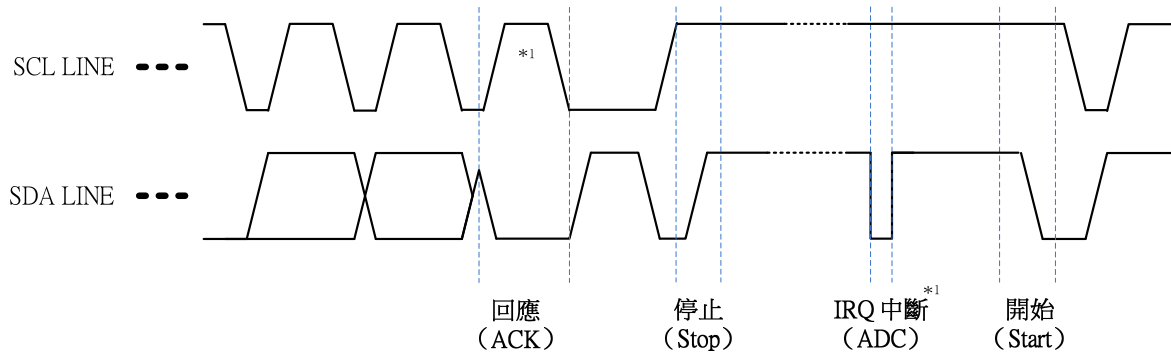

Figure 14 Interruption Wave Form (IRQ) of Communication I²C

波形描述定義 (Wave Definition)

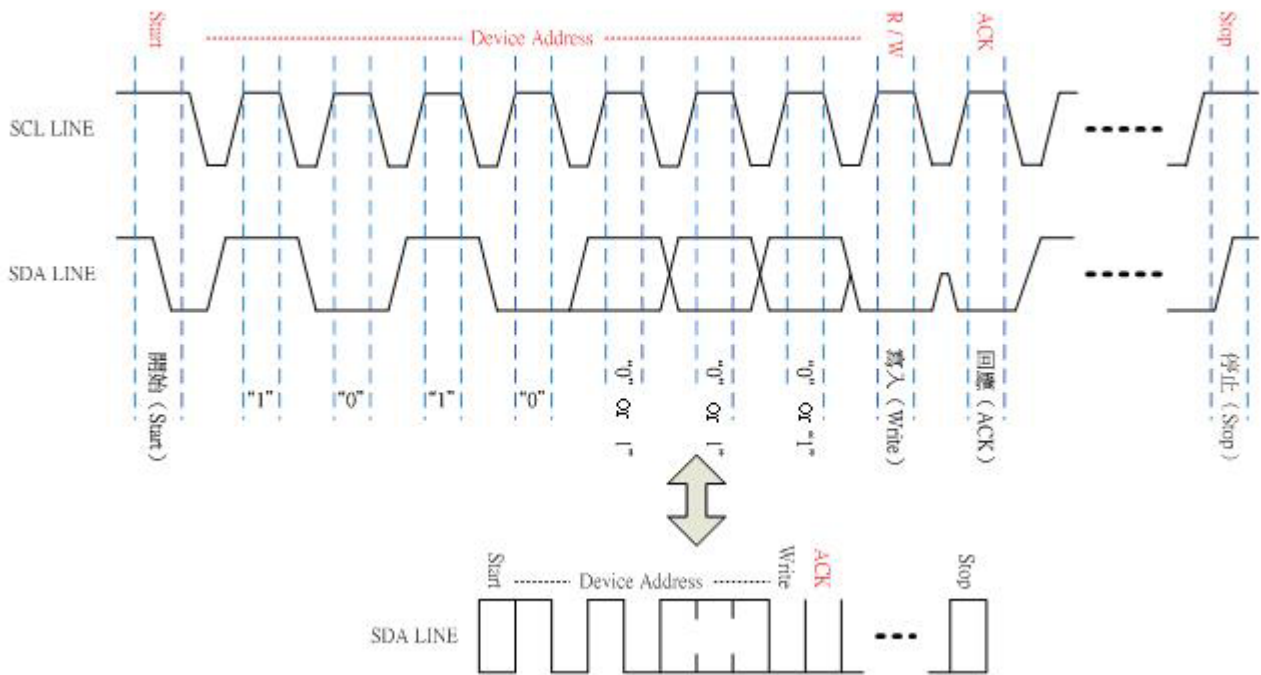
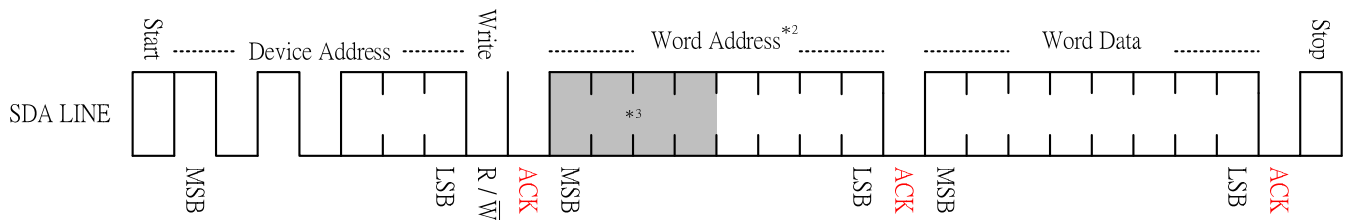

Figure 15 Wave Definition

暫存器的寫入 (Write Register)



*2 When write-in word address is bigger than 04h, there will be no ACK response and no word address update and the I2C communication will be terminated. Communication resumes after the I2C communication is stopped and started again.

*3 Write-in value of these four bits must all be zero to avoid chip's malfunctioning.

Figure 16 Write Register of Communication I²C

暫存器的讀取 (Read Register)

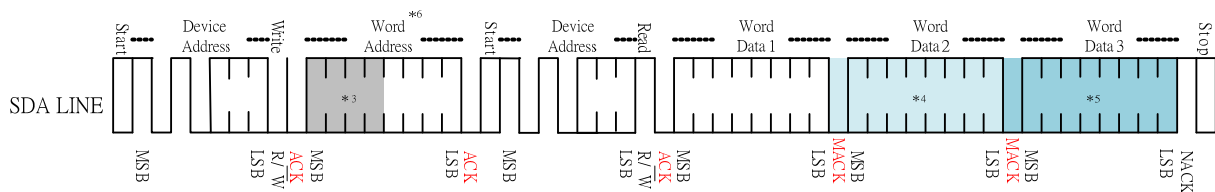

*4 When read in values at word address 00h ~ 04h the return value is word data 1 only.

*5 When read in values at word address 05h (ADO) the return value is word data 1+word data 2+word data 3. When Data 2/Data 3 have to be returned, MACK has to be set to low by master control terminal.

*6 When read in values at word address bigger than 06h, there will be no ACK response and no word address update and the I2C communication will be terminated. Communication resumes after the I2C communication is stopped and started again.

Figure 17 Read Register of Communication I²C

HY3118/HY3116

24-Bit Analog-to-Digital Convert

High Resolution Σ ADC

重新讀取暫存器 (Reread Register)

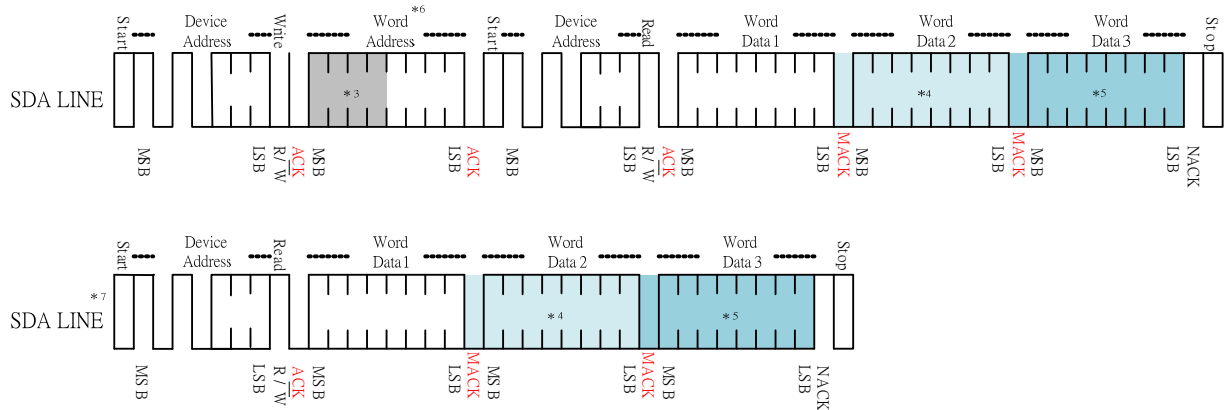

*7 When reading a word address that has been specified for reading once, no assignment are required for the following readings.

Figure 18 Re-read Register of Communication I²C

暫存器的寫入確認 (Write Register then Read Register)

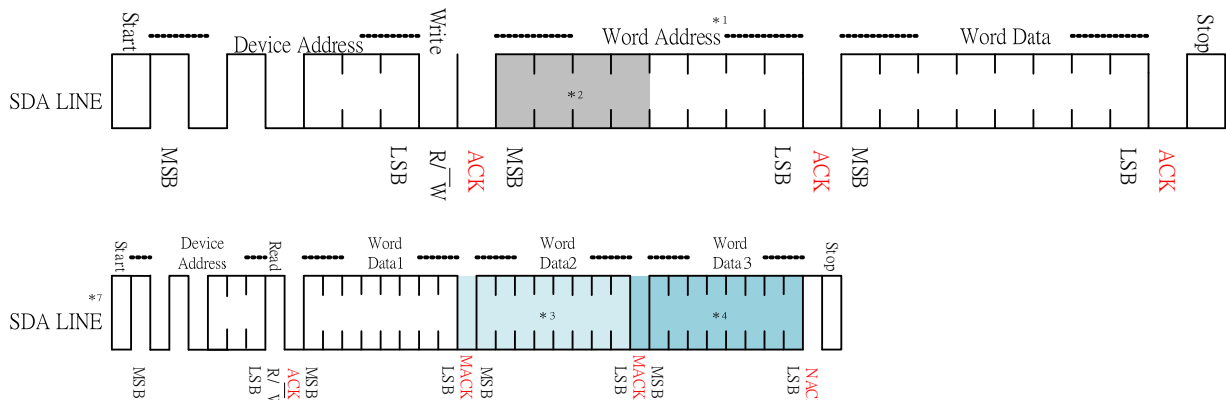

*7 When the word data in a word address that has been specified for writing once, no assignment is required for the following readings.

Figure 19 Write Register then Read Register of Communication I²C

HY3118/HY3116

24-Bit Analog-to-Digital Convert

High Resolution Σ ADC

中斷 IRQ 的 ADO 暫存器讀取(IRQ Read Register)

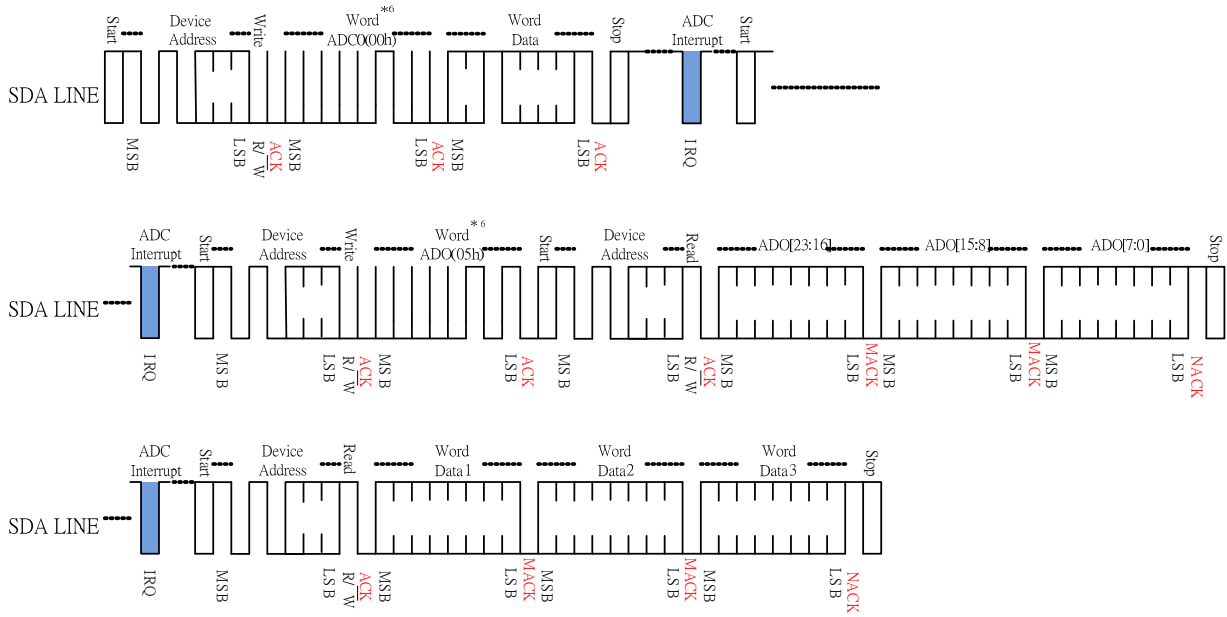

Figure 20 IRQ Read Register

復位晶片 (Call Chip Reset)

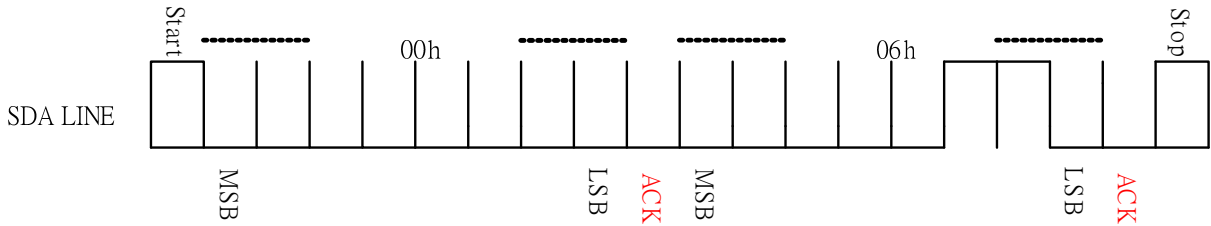

Figure 21 Call Chip Reset of Communication I²C

9. Overview

9.1. Frequency vs. Low Power mode

- Optional internal and external oscillators
 - 327KHz low speed RC oscillator
 - 1000KHz high speed RC oscillator
 - External oscillator through frequency divider of 5 folds frequency elimination
 - External oscillator through frequency divider of 15 folds frequency elimination
 - Programmable operating frequency and $\Sigma\Delta$ ADC sampling frequency
- Low power mode design
 - Chip sleep mode
 - Auto Power Off mode

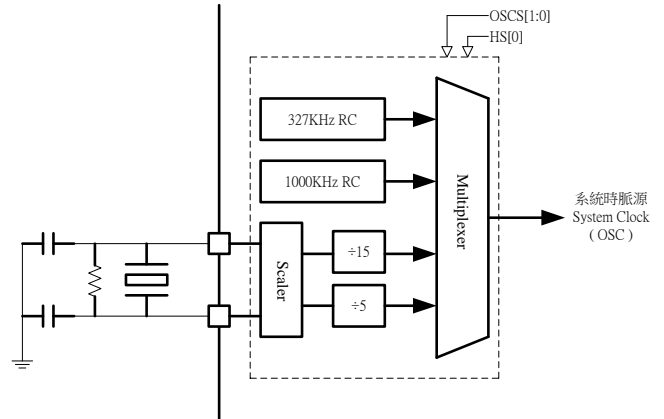

Figure 22 System Clock Diagram

Select system clock (same as ADC sampling rate) by configuring oscillator OSCS[1:0] to generate system's operating frequency (OSC). When sampling frequency of $\Sigma\Delta$ ADC is running at above 327 KHz, please set value of register HS[0] to "1" to switch to high speed mode. Chip's loss current increases when $\Sigma\Delta$ ADC is set to high speed mode.

Register	OSCS[1:0]	00	01	10	11
	OSC	HS[0]	0	1	0/1
System Clock		327KHz	1000KHz	EXO ÷ 15	EXO ÷ 5
ADC Sample Rate		327KHz	1000KHz	EXO ÷ 15	EXO ÷ 5

0/1: Set to "1" when divided frequency of system clock is more than 327KHz.

EXO: frequency of external frequency

Table 11 System Operating Clock and ADC Sampling Frequency

For the 50/60Hz interference caused by AC power, it is recommended to use an external oscillator with crystal frequency of 4.9152MHz as the internal RC oscillator, which tolerance is 5% may lead to poor performance in rejecting AC power interference.

There are two low power modes: auto close and sleep.

- ◆ Turn on the "auto close" mode if you want to turn the chip off after the latest ADC data is converted.
 - Set APO[0] to "1" in testing mode to turn on the "auto close" function.
 - Set APO[0] to "1", then the ADC set registers ENLDO[0] and ENADC[0] to "0" after the last ADO[23:0] conversion to switch off chip power and enter sleep mode.

HY3118/HY3116

24-Bit Analog-to-Digital Convert

High Resolution $\Sigma\Delta$ ADC

- I2C communication interface is of low power design. Please ensure that the pull-up resistor pin is not at low potential.
- ◆ Loss current at sleep mode decreases to lower than 1uA. Please follow steps described below to enter this chip into sleep mode:
 - Set register ENADC[0] to “0” to power off both internal and external oscillators
 - Set register ENOP[0], ENLDO[0] and ENREFO[0] to “0” to power off operation amplifiers OPAMP、VDDA and REFO。
 - I2C communication interface is of low power design. Please ensure that the pull-up resistor pin is not at low potential.

9.2. VDDA Power (Low Dropout Regulator)

- 10mA load driving capacity
- Programmable output voltage
- Optional external voltage input
- Low temperature coefficient

VDDA is a voltage source to the ADC, OPAMP and input buffer with low temperature drift coefficient and programmable linear output regulator. Featuring programmable output voltage, 10mA load capacity and low temperature drift coefficient circuit, is perfect in driving small current sensor.

For measuring system that requires shared power supply, users may turn off VDDA and drive with external input voltage. Set register ENLDO[0] to “1” to enable VDDA. Select VDDA’s output voltage through register LDO[1:0].

LDO	register	ENLDO[0]* ¹	1	1	1	1	0	0	0	0
	LDO[1:0]		00	01	10	11	00	01	10	11
VDDA* ¹			3.3V	3.0V	2.7V	2.4V	off/EXT			

*¹off/EXT: no VDDA output voltage and accept external input voltage

Table 12 Configuration of VDDA's Output Voltage

9.3. REFO Reference Voltage

- 200uA load driving capacity
- Programmable output voltage
- Optional external voltage input
- Low temperature coefficient

With low temperature drift coefficient and programmable REFO reference voltage output, it suits your needs for reference voltage for it is the power source of analog circuit common ground, programmable output voltage, 200uA load capacity and low temperature drift coefficient circuit design.

For measuring system that requires common reference voltage, you may turn off REFO and drive with external input voltage. Set register ENREFO[0] to “1” to enable REFO. Select REFO’s output voltage through register REFO[0].

Register	ENREFO[0]* ¹	1	1	/	/	0	0	/	/
REFO	REFO[0]	0	1	/	/	0	1	/	/
REFO* ¹		1.2V	1.5V	/	/	off/EXT			

*¹off/EXT: no REFO output voltage and accept external input voltage

Table 13 Configuration of REFO’s Output Voltage

9.4. Input Channel Multiplexer with IRQ

- Flexible input multiplexer for measurement and reference signal
- Network switchable input multiplexer design and ADC conversion data suppression function
- Steady time calculation for ADC conversion data suppressed output
- Response IRQ function for end of ADC data conversion

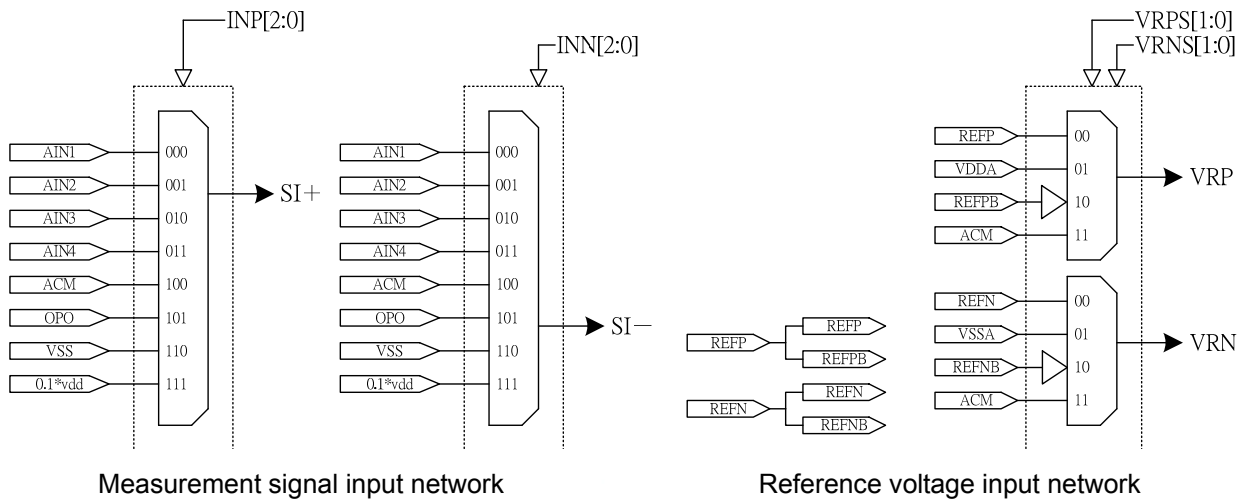

Figure 23 Input Channel Multiplexer

Signal input is featured with flexible network switchable multiplexer design. After the input network controller is switched, the embedded data conversion suppressor is initiated to delay data update in ADO[23:0] register until ADC data conversion is completed. The data update steady time can be derived from the equation described below:

$$t_{Stable}^{ADC} \cong 128 \times \frac{1}{f_{OSCS}^{ADC}} + 4 \times \frac{1}{f_{OSR}^{ADC}} \dots\dots\dots (Formula 1)$$

t_{Stable}^{ADC} : steady time after ADC network switch
 f_{OSCS}^{ADC} : ADC sampling frequency
 f_{OSR}^{ADC} : ADC conversion frequency

If IRQEN<0> of ADC4[7:0] is set to “1”, then a piece of data will be written into register ADO[23:0] and an IRQ signal will be generated at SDA pin. The IRQ signal is a low potential pulse signal that triggers the master end to read contents in ADO[23:0] after being received at the master end.

Please note that after configuration of the input channel multiplexer is switched, both the +/- input short or exchange and reference voltage change need a period of t_{Stable}^{ADC} before the ADC can generate valid conversion data or interruption response IRQ.

9.5. Reference Voltage and its Input Channel with VREF

- Full differential signal input design
- Rail-to-Rail signal input voltage level
- Low-Drift and Low-Noise design
- Programmable reference voltage attenuation factor
- Input buffer design
- Input impedance matching relation

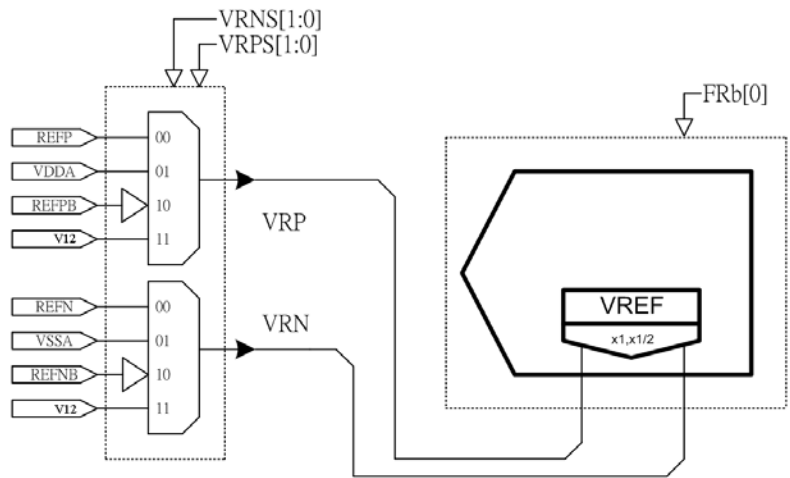

Figure 24 Reference Voltage Input and Attenuator

Reference voltage of full differential input design as well as embedded programmable input attenuator featuring Low-Drift and Low-Noise

The reference voltage input can be configured with proper input channel through multiplexer VRPS[1:0] and VRNS[1:0] as described in Table 14.

Register Channel	VRPS[1:0] / VRNS[1:0]						
	00	01	10	11			
VRP	REFP	VDDA	REFPB	V12 ⁻¹			
VRN	REFN	VSSA	REFNB	V12 ⁻¹			

V12: internal reference voltage 1.2V.

Table 14 Configuration Table for Measurement Signal Input

ΔV_{REF} voltage difference is generated based on reference voltage input from pin REFP and REFN. It then generates reference voltage VREF for Σ ADC, REFP input voltage always bigger than REFN, based on attenuation factor selected by register FRb[0] which is controlled by programmable reference voltage attenuator.

Register G _{REF}	FRb[0]						
	0	1					
Gain	1	1/2					

Table 15 Cross Reference of Factors of Reference Voltage Attenuator

Value of VREF is derived by formulas described below:

$$\Delta V_{REF} = V_{REFP} - V_{REFN} \dots\dots\dots \text{(Formula 2)}$$

$$VREF = G_{REF} \times \Delta V_{REF} \dots\dots\dots \text{(Formula 3)}$$

ΔV_{REF} : The voltage difference caused by the external input PIN
 V_{REFP} , V_{REFN} : The voltage caused by the external input PIN ($V_{REFP} > V_{REFN}$)
 G_{REF} : Reference voltage input and attenuator
 $VREF$: ADC internal reference voltage

Please note that the design value of input impedance of REFP / REFN is 500K Ω , input voltage to REFP or REFN must be greater than VSS -100mV and less than VDDA +100mV. You may increase the input impedance to REFP and REFN by setting input of VRP / VRN to REFPB / REFNB with the constraint that the input voltage to REFP is greater than 1.2V and the input voltage to REFN is smaller than VDDA - 1.2V.

Signal end Pin end	VRP	VRN
REFP	$VSSA - 0.1V \leq REFP \leq VDDA + 0.1V$	
REFN	$VSSA - 0.1V \leq REFN \leq VDDA + 0.1V$	
REFPB	$VSSA + 0.15V \leq REFN \leq VDDA - 1.2V$	
REFNB	$VSSA + 1.2V \leq REFP \leq VDDA - 0.15V$	

Table 16 Constraints on Reference Voltage Input

9.6. Measurement Signal Input Channel with PGA

- Full differential signal input design
- Rail-to-Rail signal input voltage level
- Low-Drift and Low-Noise design
- Programmable reference voltage attenuation factor
- Input signal zero offset design
- Minimum resolution signal: $100nV_{RMS}$

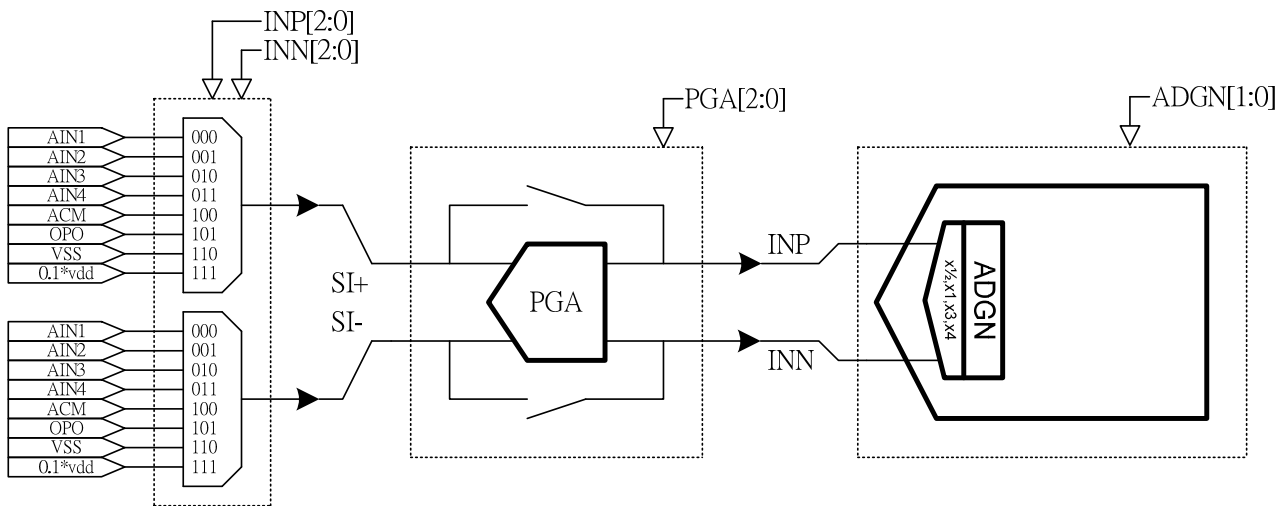

Figure 25 Signal Input and Amplified

Full differential design based signal measurement may be used in the single-end signal measurement. Embedded low-drift and low-noise PGA may reach a minimum signal input resolution at $100nV_{RMS}$ when input signal is amplified 128 folds (PGA set to 32 folds and $\Sigma\Delta$ AD to 4 folds).

Input signal may connect to SI+ or SI- channel through multiplexer. Control register of the multiplexer is INP[2:0] and INN[2:0].

Register channel	INP[2:0] / INN[2:0]							
	000	001	010	011	100	101	110	111
SI+	AIN1	AIN2	AIN3	AIN4	REFO	OPO	VSSA	0.1*VDD
SI-	AIN1	AIN2	AIN3	AIN4	REFO	OPO	VSSA	0.1*VDD

Table 17 Cross Reference of Measurement Signal Input Configuration

Amplification rate of input signal is determined by gains from $\Sigma\Delta$ AD. Available magnification rates and ranges of input voltage are presented in Table 18, Table 19, and Table 20, Input Impedance generated by different PGA and $\Sigma\Delta$ AD Gain Composition is shown as Table 21 :

HY3118/HY3116

24-Bit Analog-to-Digital Convert

High Resolution $\Sigma\Delta$ ADC

Register PGA	PGA[2:0]							
	000	001	010	011	100	101	110	111
Gain	off	8	-	16	-	-	-	32

Table 18 Amplification Rate of Input Signal by PGA

Register $\Sigma\Delta$	ADGN[1:0]							
	00	01	10	11				
Gain	1	2	-	4				

Table 19 Amplification Rate of Input Signal by $\Sigma\Delta$

Signal end Pin end	SI+	SI-
AIN0	$VSSA - 0.1V \leq AIN0 \sim AIN3 \leq VDDA + 0.1V$	
AIN1		
AIN2		
AIN3		
VDDA	$2.3V \leq VDDA \leq 3.6V$	
REFO	$1.0V \leq REFO \leq 1.5V$	

Table 20 Attributes of Reference Voltage Input Limit

Gain	=	PGA	×	ADGN	×	FRb	Sensor output impedance(K Ω)
1	=	1	×	1	×	1	200
2	=	1	×	2	×	1	100
4	=	1	×	4	×	1	32
32	=	8	×	4	×	1	4
64	=	16	×	4	×	1	2
128	=	32	×	4	×	1	1

Table 21 Input Impedance generated by PGA and $\Sigma\Delta$ Gain

HY3118/HY3116

24-Bit Analog-to-Digital Convert High Resolution $\Sigma\Delta$ ADC

All the application input signals of different measurements are attributed with zero offset (translation adjustment). You may change location of the input signal's zero point to improve the maximum measurement range overflow caused by too large an input offset voltage from the sensor. See Figure 25 for an illustration on 16-bit (± 15 -bit) sampling to a measurement signal. Before doing a zero shift adjustment, overflow in the full range exists, but not after running a $-1/4$ VREF zero offset alignment.

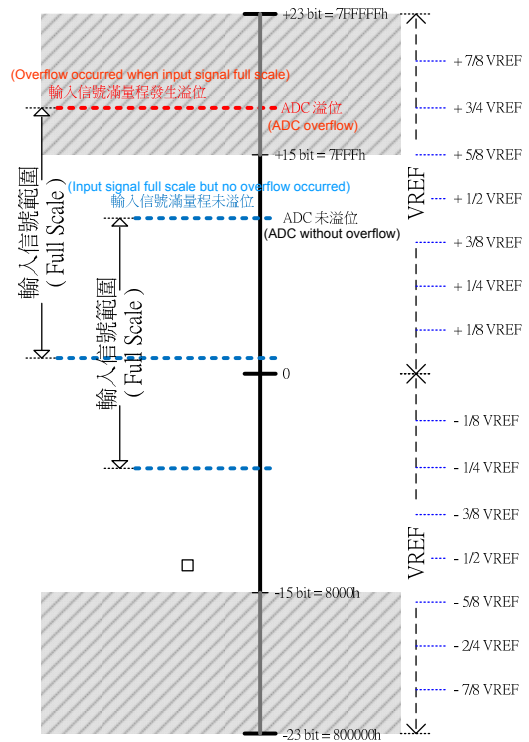

Figure 26 Overflow Treatment of 16 Effective Bits

9.7. COMB Filter

- 3-tier COMB filter
- AC frequency interference suppression
- Programmable over sampling frequency

3-tier digital filter based $\Sigma\Delta$ ADC can get different data conversion frequency by changing settings of OSR[2:0].

Register OSR	OSR[2:0]							
	000	001	010	011	100	101	110	111
OSR	128	256	512	1024	2048	4096	8192	32768

Table 21 Frequency Division for Over-sampling Frequency

OSR	OSCS / HS	00	01	10	11	OSCS[1:0]
		0	1	1	0	HS[0]
OSR[2:0]	000	2500	7812.5	7680	2560	EXO: external
	001	1250	3906.2	3840	1280	4.9152MHz crystal oscillator
	010	625	1953.1	1920	640	
	011	312.5	976.5	960	320	
	100	156.2	488.2	480	160	
	101	78.1	244.1	240	80	
	110	39	122	120	40	
	111	9.7	30.5	30	10	

Table 22 $\Sigma\Delta$ ADC Over-sampling Conversion Frequency

For a 4.9152MHz external oscillator the output frequency of $\Sigma\Delta$ ADC may range in 2560, 640, 80 and 10Hz. See Figure 26 for suppression of the 10SPS frequency response to the 50/60Hz interference from AC power.

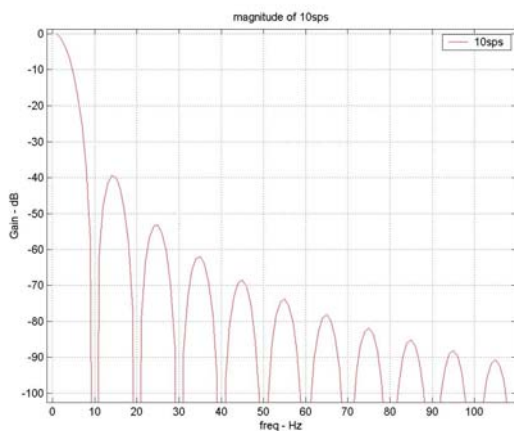

Figure 27 10SPS Frequency Response

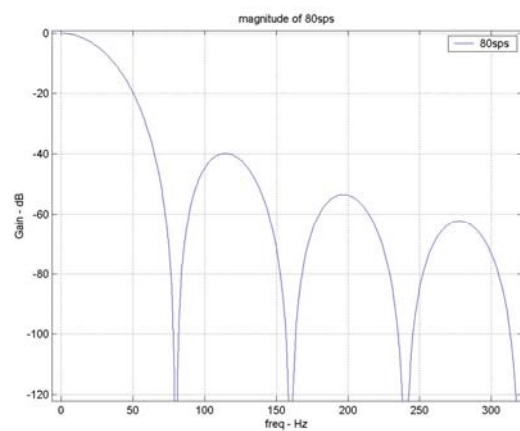

Figure 28 80SPS Frequency Response

HY3118/HY3116

24-Bit Analog-to-Digital Convert

High Resolution $\Sigma\Delta$ ADC

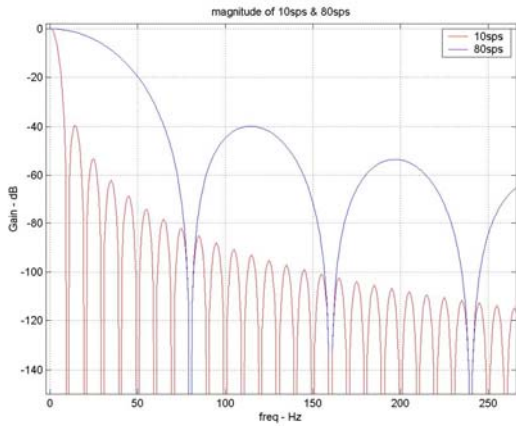

Figure 29 10/80SPS Frequency Response

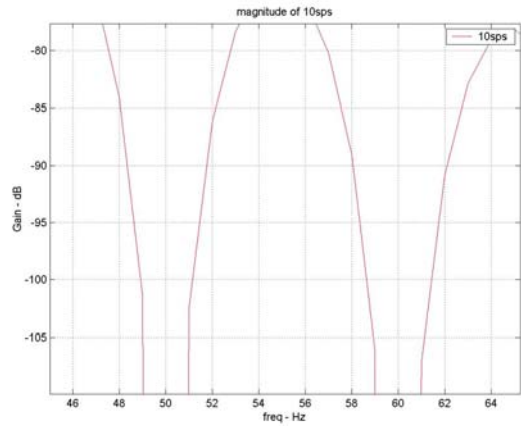

Figure 30 Magnified 10SPS Frequency Response

9.8. Data Conversion Format

- ADO register
- 24-bit data length
- Bi-polar output
- Two's complement format

Data converted by COMB filter is saved in the ADO register. The converted external input signal is stored in ADO[23:0]. See Figure 30 for data format of ADO[23:0] where ADO[23:1] is ADC's conversion output and ADO[0] the read status flag, ADST[0], of ADO.

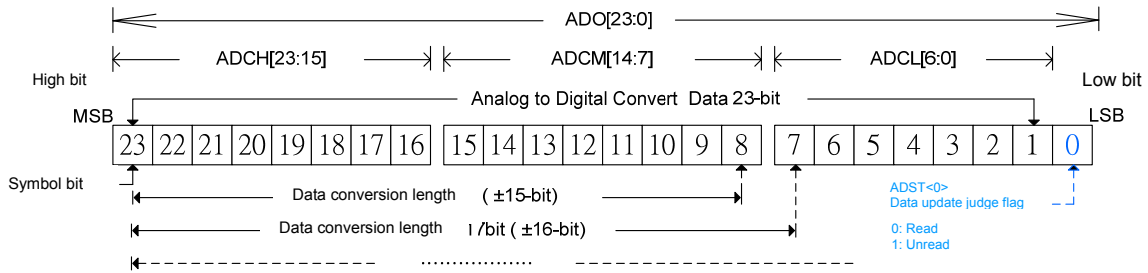

Figure 31 ADO Data Conversion Format

	Equivalent test pending signal	ADO[23:0]	
		hexadecimal	Binary coded decimal
Bipolar output Two's complement format	ΔVR	7F FF FE	0111-1111 1111-1111 1111-111x
	$\Delta VR \cdot (1/2^{22})$	00 00 02	0000-0000 0000-0000 0000-001x
	0	00 00 00	0000-0000 0000-0000 0000-000x
	$-\Delta VR \cdot (1/2^{22})$	FF FF FE	1111-1111 1111-1111 1111-111x
	$-\Delta VR$	80 00 00	1000-0000 0000-0000 0000-000x

Table 23 Relation between ADO[23:0] and Input Signal

9.9. Rail-to-Rail OPAMP

- Rail-to-Rail signal input design
- 1mA I/O current

Rail-to-Rail OPAMP design with 90dB DC gain and 70dB CMRR for a maximum of 1uF capacitive load. Voltage range of the ORAMP’s input signal can be found in Table 14.

Signal OPAMP	Range of OPAMP input voltage
OPP	$VSSA \leq OPP \leq VDDA$
OPN	$VSSA \leq OPN \leq VDDA$

Table 24 Constraints on Reference Voltage Input

Output voltage of ORAMP OPO is smaller than 0.3V or greater than VDDA - 0.3V. Output impedance of ORAMP may increase. Figure 31 is the change curve of OPO output impedance when ORAMP is set to a unit gain buffer.

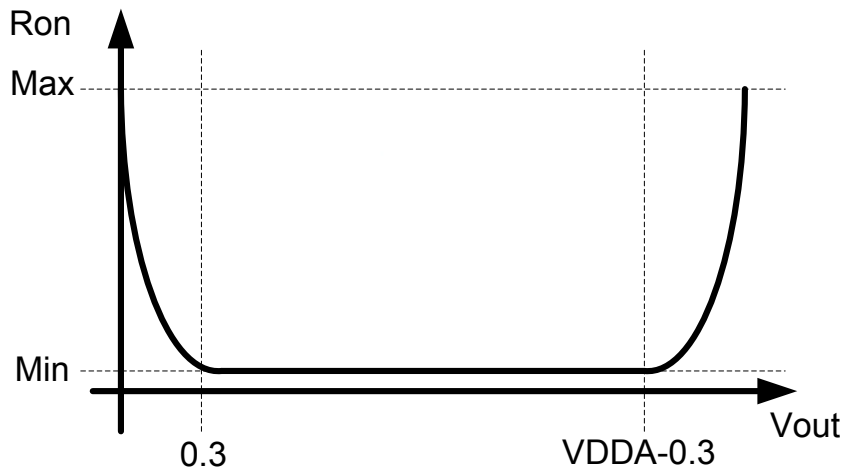

Figure 32 Change Curve of OPO Output Impedance

You may set ENOP[0] to “1” to use the Rail-to-Rail ORAMP. Please make sure that the VDDA is set to ON when using the ORAMP. The OPO output signal can be detected by ADC only by setting up register INP[2:0] and INN[2:0].

10. Ordering Information

Device No. ¹	Package Type	Pins	Package Drawing		Shipment Packing Type	Unit Q'ty	Material Composition	MSL ²
			E	016				
HY3118-E016	SSOP	16	E	016	Tube	100	Green ³	MSL-3
HY3118-E016	SSOP	16	E	016	Tape & Reel	2500	Green ³	MSL-3
HY3116-M010	MSOP	10	M	010	Tape & Reel	3000	Green ³	MSL-3

¹ Device No.: Model No. – Package Type Description (Standard Code)

Ex: You request HY3118 in SSOP16 package and shipment packing type is Tube.

The device number will be HY3118-E016. And please clearly indicate the shipment packing type (Tube) when placing orders.

Ex: You request HY3116 in MSOP10 package and shipment packing type is

Tape & Reel. The device number will be HY3116-M010.

And please clearly indicate the shipment packing type (Tape & Reel) when placing orders.

² MSL:

The Moisture Sensitivity Level ranking conforms to IPC/JEDEC J-STD-020 industry standard categorization. The products are processed, packed, transported and used with reference to IPC/JEDEC J-STD-033.

³ Green (RoHS & no Cl/Br):

HYCON products are Green products that are compliant with RoHS directive, SVHC under REACH and Halogen free.

HY3118/HY3116

24-Bit Analog-to-Digital Convert

High Resolution $\Sigma\Delta$ ADC

11. Package Information

11.1. SSOP16

11.1.1. Package Dimensions

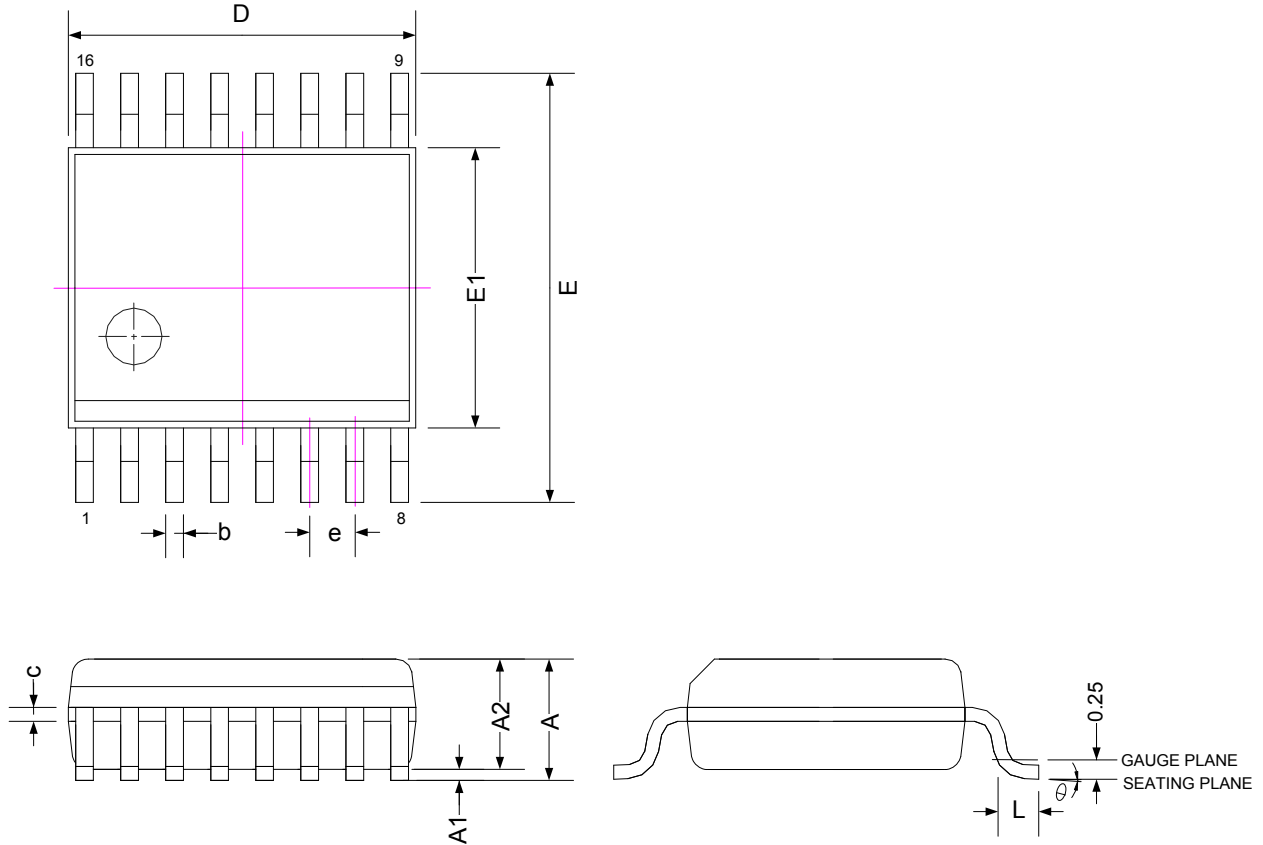

SYMBOLS	MIN	NOM	MAX
A	-	-	1.75
A1	0.10	0.15	0.25
A2	-	-	1.50
b	0.20	-	0.30
c	0.18	-	0.25
D	4.80	4.90	5.00
E1	3.81	3.91	3.99
E	5.79	5.99	6.20
L	0.41	-	1.27
e	0.635 BASIC		
θ°	0	-	8

Note:

1. All dimensions refer to JEDEC OUTLINE MO-137.
2. Do not include Mold Flash or Protrusions.
3. Unit : mm

11.1.2. Tube Dimensions

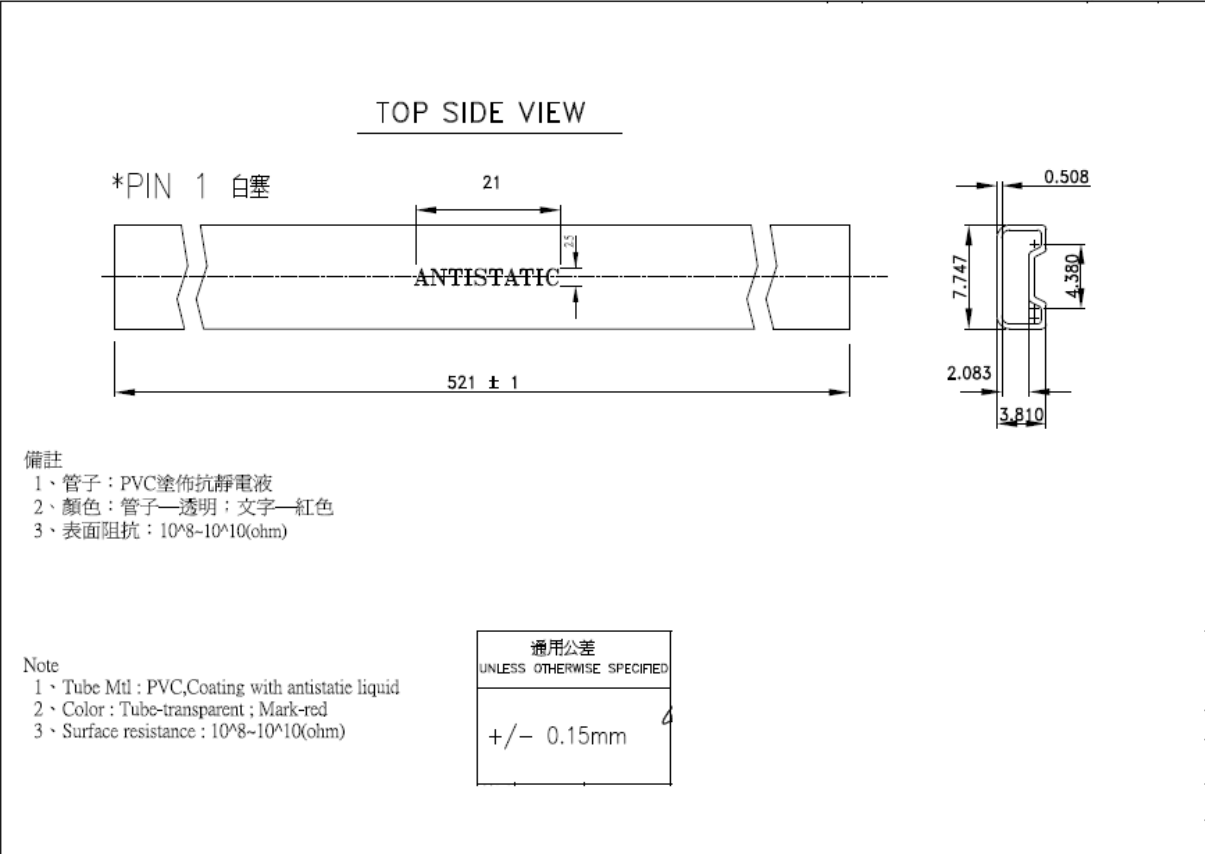
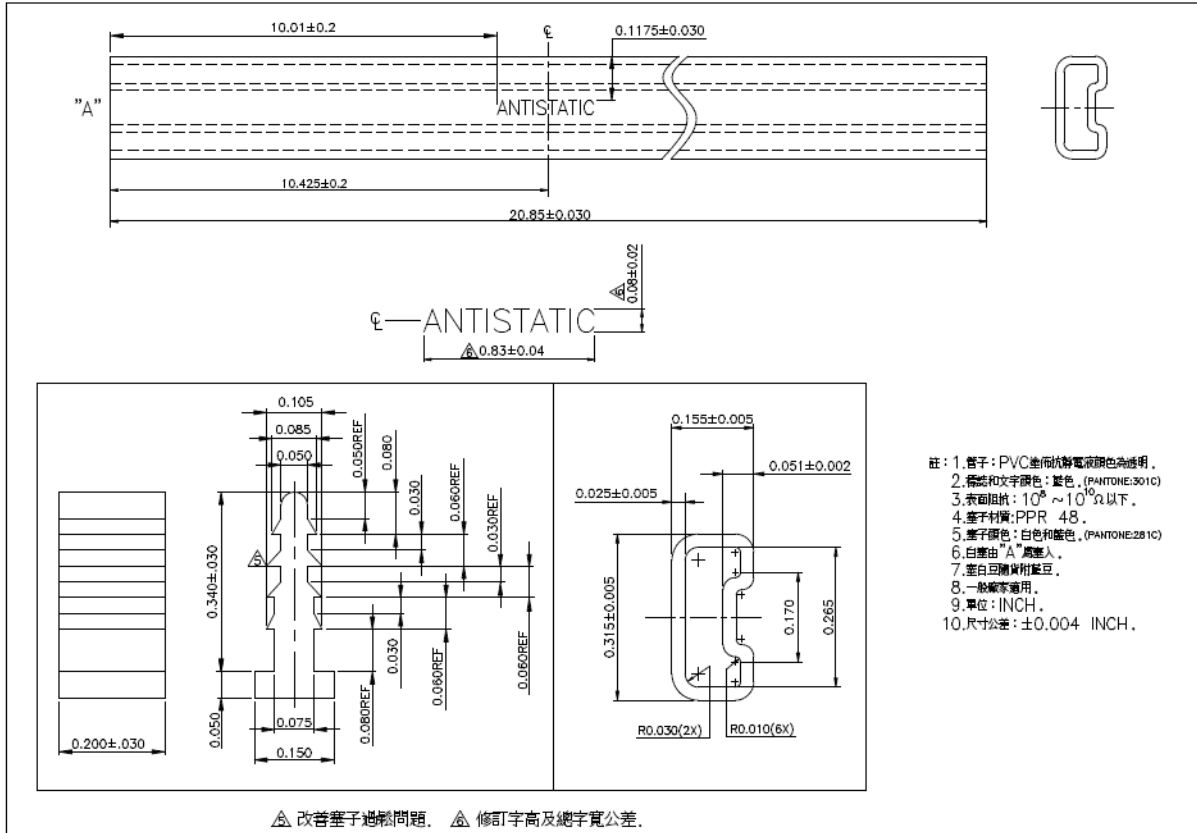

11.1.3. Tape & Reel Information

11.1.3.1. Reel Dimensions-Type 1..... Unit : mm

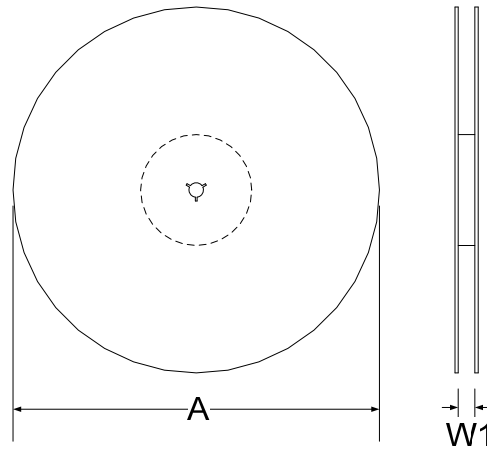

11.1.3.2. Carrier Tape Dimensions

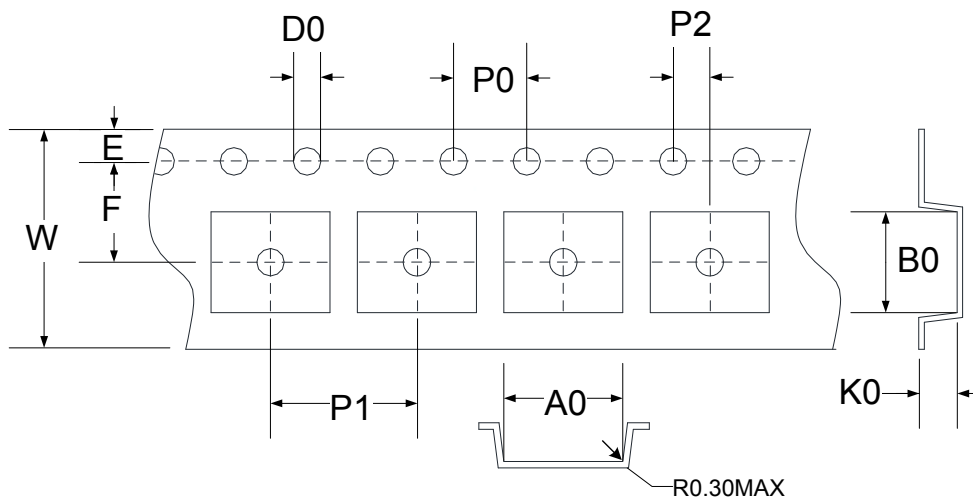

SYMBOLS	Reel Dimensions		Carrier Tape Dimensions									
	A	W1	A0	B0	K0	P0	P1	P2	E	F	D0	W
Spec.	330	12.5	6.90	5.40	2.00	4.00	8.00	2.00	1.75	5.50	1.50	12.00
Tolerance	+6/-3	+1.5/-0	±0.10	±0.10	±0.10	±0.10	±0.10	±0.05	±0.10	±0.05	+0.1/-0	±0.30

Note: 10 Sprocket hole pitch cumulative tolerance is ± 0.20 mm.

Unit : mm

11.1.3.3. Pin1 direction

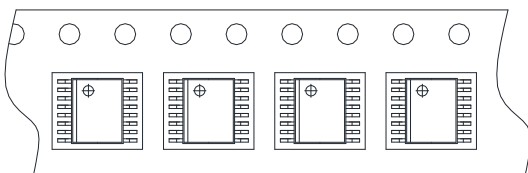

HY3118/HY3116
24-Bit Analog-to-Digital Convert
High Resolution $\Sigma\Delta$ ADC

11.1.3.4. Reel Dimensions-Type 2..... Unit : mm

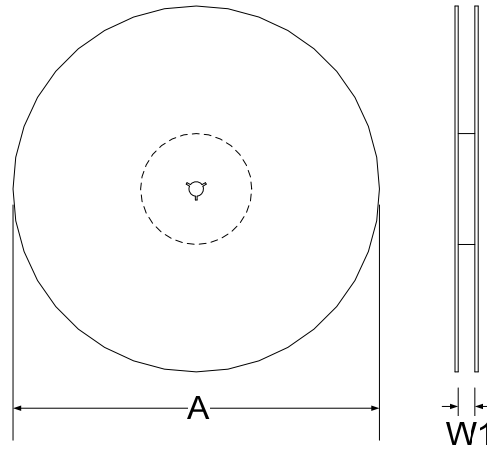

11.1.3.5. Carrier Tape Dimensions

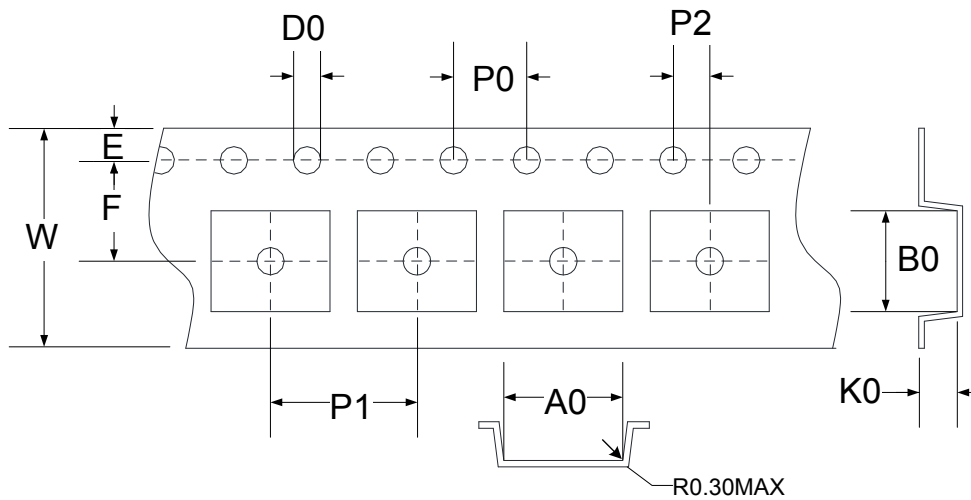

SYMBOLS	Reel Dimensions		Carrier Tape Dimensions									
	A	W1	A0	B0	K0	P0	P1	P2	E	F	D0	W
Spec.	330	12.5	6.50	5.20	2.10	4.00	8.00	2.00	1.75	5.50	1.50	12.00
Tolerance	+6/-3	+1.5/-0	±0.10	±0.10	±0.10	±0.10	±0.10	±0.05	±0.10	±0.05	+0.1/-0	±0.30

Note: 10 Sprocket hole pitch cumulative tolerance is ± 0.20 mm.

Unit : mm

11.1.3.6. Pin1 direction

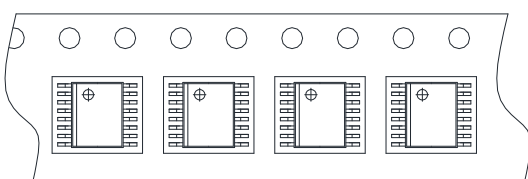

HY3118/HY3116

24-Bit Analog-to-Digital Convert

High Resolution $\Sigma\Delta$ ADC

11.2. MSOP10

11.2.1. Package Dimensions

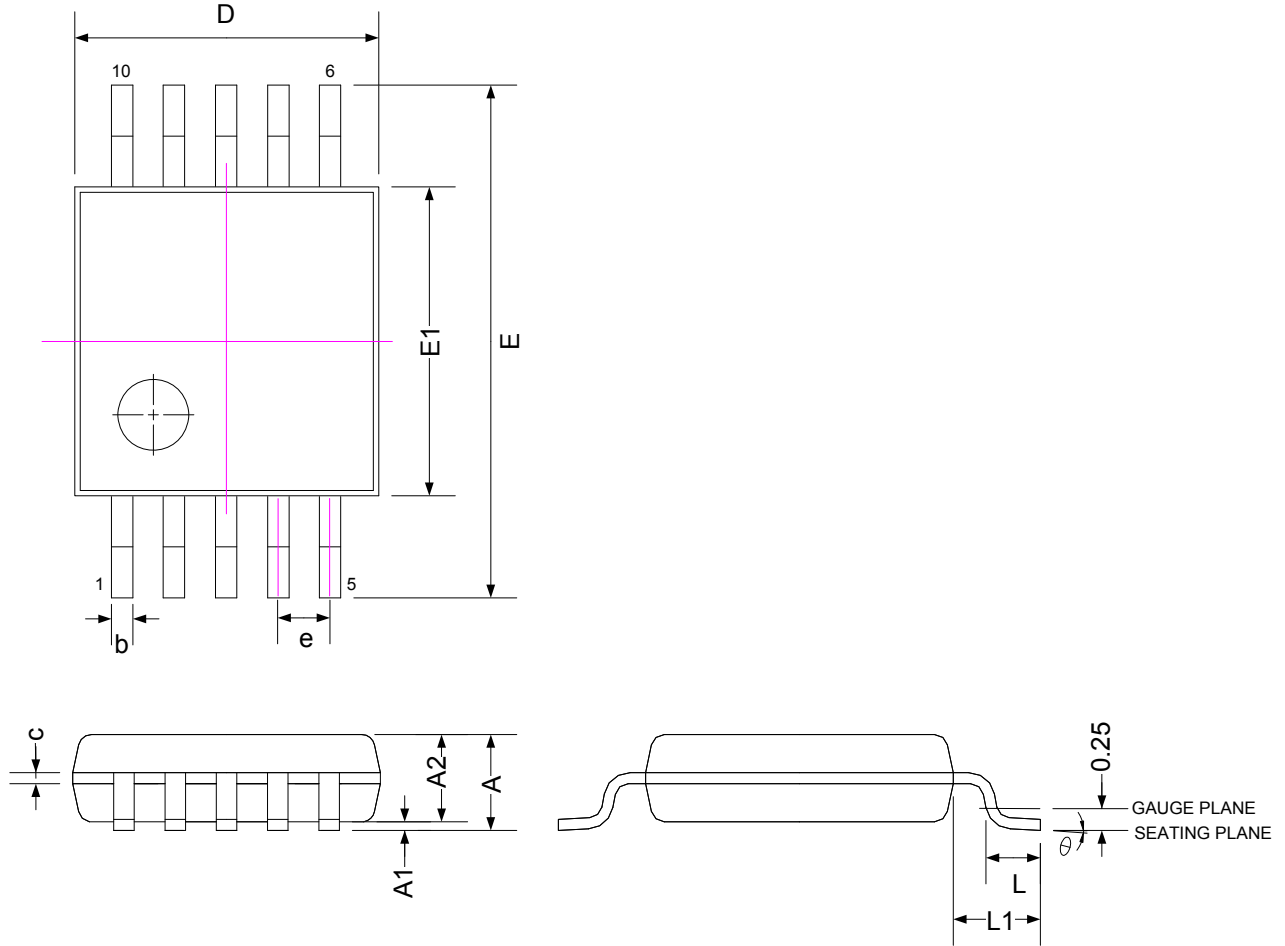

SYMBOLS	MIN	NOM	MAX
A	-	-	1.10
A1	0.00	0.10	0.15
A2	0.75	0.85	0.95
b	0.17	0.20	0.27
c	0.08	0.15	0.23
D	3.00 BASIC		
E1	3.00 BASIC		
E	4.90 BASIC		
L	0.40	0.60	0.80
L1	0.95 REF		
e	0.50 BASIC		
θ°	0	-	8

***Note:**

- 1.All dimensions refer to JEDEC OUTLINE MO -187.
- 2.Do not include Mold Flash or Protrusions.

HY3118/HY3116
24-Bit Analog-to-Digital Convert
High Resolution $\Sigma\Delta$ ADC

11.2.2. Tape & Reel Information

11.2.2.1. Reel Dimensions-Type 1..... Unit : mm

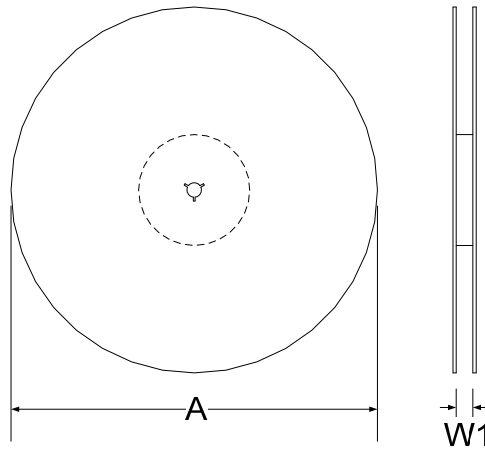

11.2.2.2. Carrier Tape Dimensions

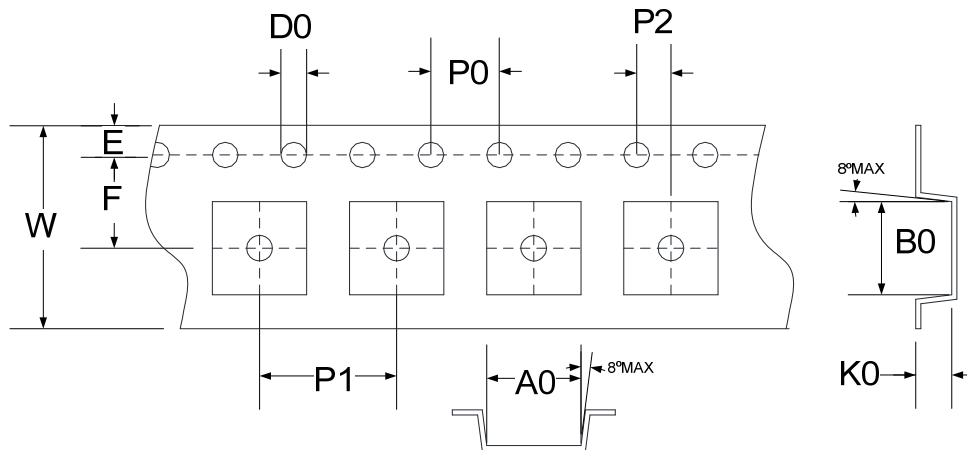

SYMBOLS	Reel Dimensions		Carrier Tape Dimensions										
	A	W1	A0	B0	K0	P0	P1	P2	E	F	D0	W	
Spec.	330	12.5	5.30	3.40	1.40	4.00	8.00	2.00	1.75	5.50	1.50	12.00	
Tolerance	±2.00	±1.50	±0.10	±0.10	±0.10	±0.10	±0.10	±0.10	±0.05	±0.10	±0.05	+0.1/-0	±0.20

Note: 10 Sprocket hole pitch cumulative tolerance is ±0.20mm.

Unit : mm

11.2.2.3. Pin1 direction

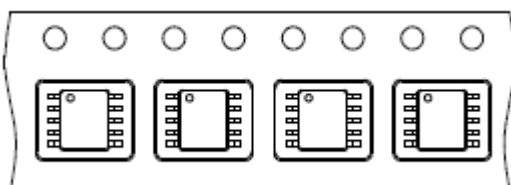

11.2.2.4. Reel Dimensions-Type 2..... Unit : mm

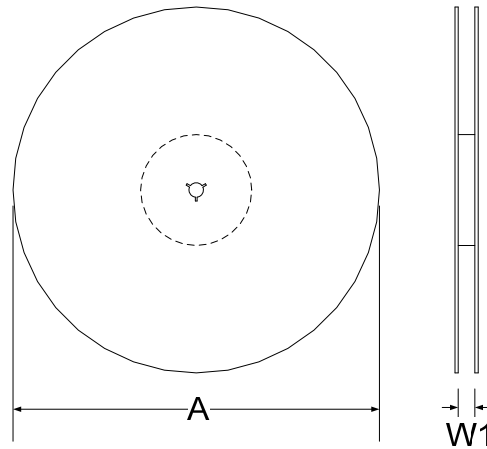

11.2.2.5. Carrier Tape Dimensions

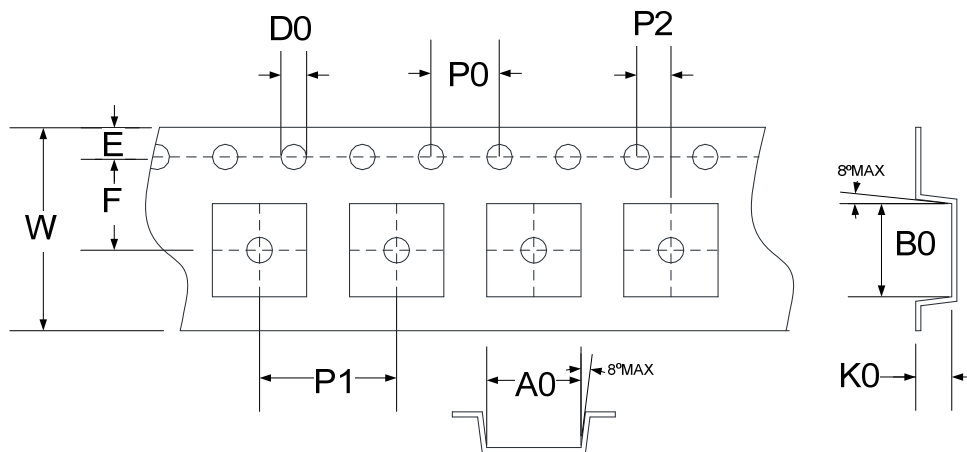

SYMBOLS	Reel Dimensions		Carrier Tape Dimensions										
	A	W1	A0	B0	K0	P0	P1	P2	E	F	D0	W	
Spec.	330	12.5	5.20	3.30	1.20	4.00	8.00	2.00	1.75	5.50	1.50	12.00	
Tolerance	±2.00	±1.50	±0.10	±0.10	±0.10	±0.10	±0.10	±0.10	±0.05	±0.10	±0.05	+0.1/-0	±0.30

Note: 10 Sprocket hole pitch cumulative tolerance is ±0.20mm.

Unit : mm

11.2.2.6. Pin1 direction

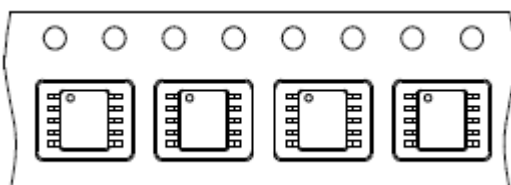

12. Revision Record

Major differences are stated thereafter:

Version	Page	Revision Summary
V04	All	First Edition
V05	45	The MSOP10 package type revision
V06	23	Revise the description of I ² C communication protocol
	26	Add Figure 33 MACK Wave Form of Communication I ² C
	27~29	Update Figure 17~Figure 21 (ACK -> MACK)
V07	44	Add in SSOP16 package information
V08	37~38	Add Input Impedance Table
V09	9	Update Package marker information
	45	Update Green (RoHS & no Cl/Br)
	47	Update Tube Dimensions
	48~49	Update Tape & Reel Information
	51~52	Update Tape & Reel Information