



HY2118

Data Sheet

1-Cell Lithium-ion/Lithium Polymer
Battery Packs Protection ICs

Table of Contents

1. GENERAL DESCRIPTION	5
2. FEATURES	5
3. APPLICATIONS	5
4. BLOCK DIAGRAM.....	6
5. ORDERING INFORMATION	6
6. MODEL LIST.....	7
6.1. Product Name List	7
6.2. Delay Time Code-Parameter Option of Delay Time	8
6.3. Characteristic Code-Other function Option.....	8
7. PIN CONFIGURATION AND PACKAGE MARKING INFORMATION	9
8. ABSOLUTE MAXIMUM RATINGS	9
9. ELECTRICAL CHARACTERISTICS	10
10. TEST CONDITION AND CIRCUIT.....	13
10.1. Test condition	13
10.2. Test circuit.....	15
11. EXAMPLE OF BATTERY PROTECTION IC CONNECTION.....	18
12. DESCRIPTION OF OPERATION.....	19
12.1. Normal Status	19
12.2. Overcharge Status	19
12.3. Overdischarge Status	20
12.4. Discharge Overcurrent Status (Discharge Overcurrent & Short Circuit)	20
12.5. Charge Overcurrent Status	21
12.6. 0V Battery Charging Function “Unavailable”	21
13. TIMING CHART	22
14. CHARACTERISTICS (TYPICAL VALUE)	25
15. PACKAGE INFORMATION AND LAND PATTERN DESIGN RECOMMENDATIONS.....	28
15.1. DFN-1.4*1.4-6L and Land Pattern Design Recommendations.....	28
15.2. DFN-1.4*1.4-6L-EP and Land Pattern Design Recommendations	30

16. TAPE & REEL INFORMATION	32
16.1. Tape & Reel information—DFN-1.4*1.4-6L and DFN-1.4*1.4-6L-EP	32
17. REVISION RECORD	33

Attention :

1. HYCON Technology Corp. reserves the right to change the content of this datasheet without further notice. For most up-to-date information, please constantly visit our website:
<http://www.hycontek.com> .
2. HYCON Technology Corp. is not responsible for problems caused by figures or application circuits narrated herein whose related industrial properties belong to third parties.
3. Specifications of any HYCON Technology Corp. products detailed or contained herein stipulate the performance, characteristics, and functions of the specified products in the independent state. We does not guarantee of the performance, characteristics, and functions of the specified products as placed in the customer's products or equipment. Constant and sufficient verification and evaluation is highly advised.
4. Please note the operating conditions of input voltage, output voltage and load current and ensure the IC internal power consumption does not exceed that of package tolerance. HYCON Technology Corp. assumes no responsibility for equipment failures that resulted from using products at values that exceed, even momentarily, rated values listed in products specifications of HYCON products specified herein.
5. Notwithstanding this product has built-in ESD protection circuit, please do not exert excessive static electricity to protection circuit.
6. Products specified or contained herein cannot be employed in applications which require extremely high levels of reliability, such as device or equipment affecting the human body, health/medical equipments, security systems, or any apparatus installed in aircrafts and other vehicles.
7. Despite the fact that HYCON Technology Corp. endeavors to enhance product quality as well as reliability in every possible way, failure or malfunction of semiconductor products may happen. Hence, users are strongly recommended to comply with safety design including redundancy and fire-precaution equipments to prevent any accidents and fires that may follow.
8. Use of the information described herein for other purposes and/or reproduction or copying without the permission of HYCON Technology Corp. is strictly prohibited.

1. General Description

The series of HY2118 ICs is best created for single-cell lithium-ion/lithium polymer rechargeable battery protection and it also comprises high-accuracy voltage detectors and delay circuits.

These ICs are suitable for protecting single-cell rechargeable lithium-ion/lithium polymer battery packs against the problems of overcharge, overdischarge and overcurrent.

2. Features

(1) High-accuracy voltage detection circuit

- | | | |
|---|------------------|-----------------------------|
| • Overcharge detection voltage | 4.000V to 4.500V | Accuracy: $\pm 20\text{mV}$ |
| • Overcharge release voltage | 4.000V to 4.500V | Accuracy: $\pm 30\text{mV}$ |
| • Overdischarge detection voltage | 2.00V to 3.20V | Accuracy: $\pm 35\text{mV}$ |
| • Overdischarge release voltage | 2.00V to 3.20V | Accuracy: $\pm 35\text{mV}$ |
| • Discharge overcurrent detection voltage | 20mV to 50mV | Accuracy: $\pm 15\%$ |
| • Charge overcurrent detection voltage | -18mV to -40mV | Accuracy: $\pm 15\%$ |
| • Short-circuiting detection voltage | 180mV | Accuracy: $\pm 45\text{mV}$ |

(2) Delay times are generated by an internal circuit (needless external capacitors).

- | | |
|------------------------------------|------------------------|
| • Overcharge delay time | 1000ms typ. |
| • Overdischarge delay time | 20ms typ. |
| • Discharge overcurrent delay time | 12ms typ. |
| • Charge overcurrent delay time | 16ms typ. |
| • Short circuit delay time | 250 μs typ. |

(3) With Power-down function

(4) Low current consumption

- | | |
|-----------------------------------|---|
| • Operation mode | 4.0 μA typ., 8.0 μA max. (VDD=3.9V) |
| • Ultra low power-down current at | 0.1 μA max. (VDD=2.0V) |

(5) High-withstanding-voltage device is used for charger connection pins

(V- pin and OC pin: Absolute maximum rating = 20V)

(6) 0 V battery charge function: "unavailable"

(7) Wide operation temperature range -40°C to +85 °C

(8) Small package DFN-1.4*1.4-6L & DFN-1.4*1.4-6L-EP

(9) The HY2118 series are Halogen-free, green package

3. Applications

- 1-cell lithium-ion rechargeable battery packs
- 1-cell lithium polymer rechargeable battery packs

4. Block Diagram

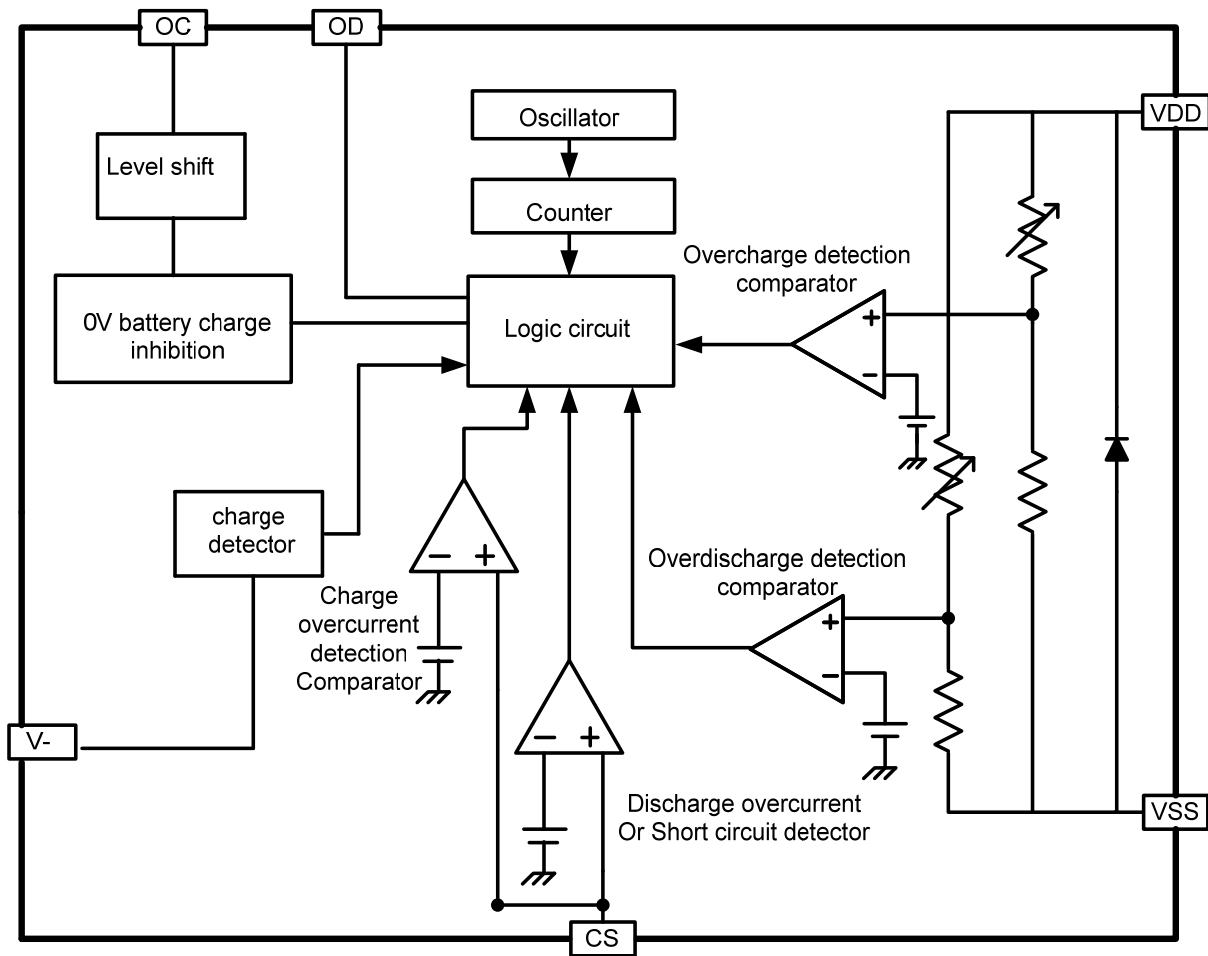

5. Ordering Information

- Product name definition

HY2118—#%\$&

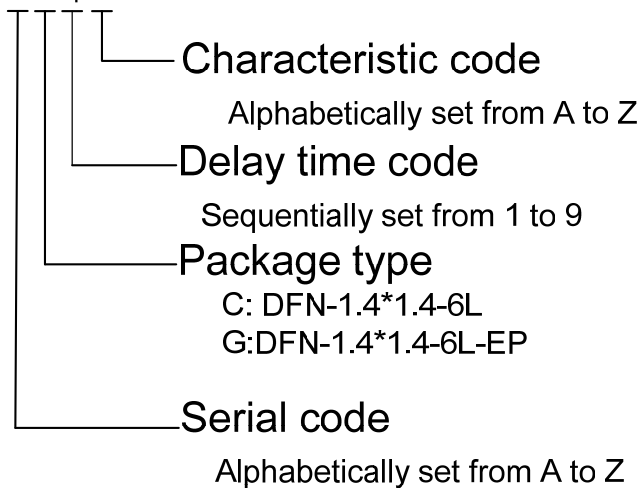

6. Model List

6.1. Product Name List

Table 1 Model list for DFN-1.4*1.4-6L

Model	Over-charge detection voltage	Over-charge release voltage	Over-discharge detection voltage	Over-discharge release voltage	Discharge overcurrent detection voltage	Charge overcurrent detection voltage	Delay Time Code	Characteristic Code
	V _{CU}	V _{CR}	V _{DL}	V _{DR}	V _{DIP}	V _{CIP}		
HY2118-AC2J	4.425V	4.425V	2.40V	2.40V	34mV	-22mV	2	J
HY2118-BC2J	4.280V	4.280V	2.40V	2.40V	32mV	-30mV	2	J
HY2118-CC2J	4.425V	4.425V	2.80V	2.80V	40mV	-30mV	2	J
HY2118-EC2J	4.470V	4.470V	2.465V	2.465V	40mV	-25mV	2	J
HY2118-FC2J	4.450V	4.450V	2.60V	2.60V	40mV	-30mV	2	J

Remark:

1. Table 1 lists out typical value of every electrical parameter. Please refer to Table 7 for detailed electrical characteristics.
2. Table 3 lists out delay time parameters of every corresponding delay time code. Table 4 lists out characteristic function of every corresponding characteristic code.
3. Please contact our sales office for the products with detection voltage value other than those specified above.

Table 2 Model list for DFN-1.4*1.4-6L-EP

Model	Over-charge detection voltage	Over-charge release voltage	Over-discharge detection voltage	Over-discharge release voltage	Discharge overcurrent detection voltage	Charge overcurrent detection voltage	Delay Time Code	Characteristic Code
	V _{CU}	V _{CR}	V _{DL}	V _{DR}	V _{DIP}	V _{CIP}		
HY2118-AG2J	4.425V	4.425V	2.40V	2.40V	34mV	-22mV	2	J
HY2118-BG2J	4.280V	4.280V	2.40V	2.40V	32mV	-30mV	2	J
HY2118-CG2J	4.425V	4.425V	2.80V	2.80V	40mV	-30mV	2	J
HY2118-EG2J	4.470V	4.470V	2.465V	2.465V	40mV	-25mV	2	J
HY2118-FG2J	4.450V	4.450V	2.60V	2.60V	40mV	-30mV	2	J
HY2118-GG2J	4.280V	4.280V	2.80V	2.80V	30mV	-20mV	2	J

Remark:

1. Table 2 lists out typical value of every electrical parameter. Please refer to Table 7 for detailed electrical characteristics.
2. Table 3 lists out delay time parameters of every corresponding delay time code. Table 4 lists out characteristic function of every corresponding characteristic code.
3. Please contact our sales office for the products with detection voltage value other than those specified above.

6.2. Delay Time Code-Parameter Option of Delay Time

Table 3 Delay Time Code- Delay Time Parameter Option

Delay Time Code	Overcharge Delay Time	Overdischarge Delay Time	Discharge Overcurrent Delay Time	Charge Overcurrent Delay Time	Short Circuit Delay Time
	T _{OC}	T _{OD}	T _{DIP}	T _{CIP}	T _{SIP}
2	1000ms	20ms	12ms	16ms	250μs

Remark:

- Table 3 lists out typical value of every delay time parameters, for detailed delay time combination please refer to Table 7.

6.3. Characteristic Code-Other function Option

Table 4 Characteristic Code-Other function Option

Characteristic Code	0 V Battery Charge Function	Power-down Function/ Auto Overdischarge Recovery Function
J	Unavailable	With power-down Function

7. Pin Configuration and Package Marking Information

Table 5 DFN-1.4*1.4-6L & DFN-1.4*1.4-6L-EP

Pin No.	Symbol	Description
1	VSS	Ground pin
2	VDD	Power supply pin
3	CS	Input pin for current sense
4	V-	Charger detect pin
5	OC	MOSFET gate connection pin for charge control
6	OD	MOSFET gate connection pin for discharge control

Type 1

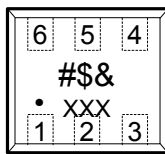

#: Serial code. Alphabetically set from A to Z.
 \$: Delay time code. Sequentially set from 1 to 9.
 &: Characteristic code. Alphabetically set from A to Z.
 xxx: Date code.

Type 2

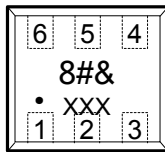

8: Serial code.
 #: Serial code. Alphabetically set from A to Z.
 &: Characteristic code. Alphabetically set from A to Z.
 xxx: Date code.

8. Absolute Maximum Ratings

Table 6 Absolute Maximum Ratings (VSS=0V, Ta=25°C unless otherwise specified)

Item	Symbol	Rating	Unit
Input voltage between VDD and VSS pin	V _{DD}	VSS-0.3 to VSS+10	V
OC output pin voltage	V _{OC}	VDD-20 to VDD+0.3	V
OD output pin voltage	V _{OD}	VSS-0.3 to VDD+0.3	V
V- input pin voltage	V-	VDD-20 to VDD+0.3	V
Operating Temperature Range	T _{OP}	-40 to +85	°C
Storage Temperature Range	T _{ST}	-40 to +125	°C
Power dissipation	P _D	250	mW

9. Electrical Characteristics

Table 7 Electrical Characteristics (VSS=0V, Ta=25°C unless otherwise specified)

Item	Symbol	Condition	Min.	Typ.	Max.	Unit
SUPPLY POWER RANGE						
Operating voltage between VDD pin and VSS pin	V_{DSOP1}	-	1.5	-	8	V
INPUT CURRENT						
Supply Current	I_{DD}	$V_{DD}=3.9V$	-	4.0	8.0	μA
Power down Current	I_{PD}	$V_{DD}=2.0V$	-	-	0.1	μA
DETECTION VOLTAGE						
Overcharge Detection Voltage	V_{CU}		V_{CU} -0.020	V_{CU}	V_{CU} 0.020	V
Overcharge Release Voltage	V_{CR}	$V_{CR} \neq V_{CU}$	V_{CR} -0.030	V_{CR}	V_{CR} +0.030	V
		$V_{CR} = V_{CU}$	V_{CR} -0.030	V_{CR}	V_{CR} +0.020	V
Overdischarge Detection Voltage	V_{DL}		V_{DL} -0.035	V_{DL}	V_{DL} +0.035	V
Overdischarge Release Voltage	V_{DR}		V_{DR} -0.035	V_{DR}	V_{DR} +0.035	V
Discharge Overcurrent Detection Voltage	V_{DIP}	$V_{DD}=3.6V, CS=V-$	V_{DIP} $\times 0.85$	V_{DIP}	V_{DIP} $\times 1.15$	mV
Short Circuit Detection Voltage	V_{SIP}	$V_{DD}=3.0V, CS=V-$	0.135	0.180	0.225	V
Charge overcurrent detection voltage	V_{CIP}	$V_{DD}=3.6V, CS=V-$	V_{CIP} $\times 0.85$	V_{CIP}	V_{CIP} $\times 1.15$	mV
Maximum Operating Voltage for Inhibition of Charger	V_{nochg}	Voltage Defined as $V_{DD}-V_{SS}, V_{DD}-V=-4V$	0.4	0.7	1.0	V
DELAY TIME						
Overcharge Delay Time	T_{OC}	$V_{DD}=3.9V \rightarrow 4.5V$	700	1000	1300	ms
Overcharge Release Delay Time	T_{CR}	$V_{DD}=4.5V \rightarrow 4.0V$	4	7	10	ms
Overdischarge Delay Time	T_{OD}	$V_{DD}=3.6V \rightarrow 2.0V$	14	20	26	ms
Overdischarge Release Delay Time	T_{DR}	$V_{DD}=3.0V, V-=3V \rightarrow 0V$	0.001	0.1	1	ms
Discharge Overcurrent Delay Time	T_{DIP}	$V_{DD}=3.6V, CS=V-=0.4V$	8	12	16	ms
Discharge Release Overcurrent Delay Time	T_{DIR}	$V_{DD}=3.6V, CS=V-=3V \rightarrow 0V$	4	7	10	ms
Charge Overcurrent Delay Time	T_{CIP}	$V_{DD}=3.6V, CS=V-=0.3V$	11	16	21	ms
Charge Overcurrent Release Delay Time	T_{CIR}	$V_{DD}=3.6V, CS=V-=1V \rightarrow 0V$	4	7	10	ms
Short Circuit Delay Time	T_{SIP}	$V_{DD}=3.0V, CS=V-=1.3V$	180	250	425	μs
Short Circuit Release Delay Time	T_{SIR}	$V_{DD}=3.6V, CS=V-=1V \rightarrow 0V$	4	7	10	ms
CONTROL OUTPUT VOLTAGE(OD&OC)						
OD Pin Output "H" Voltage	V_{DH}	$I_{oh}=-30\mu A, V_{DD}=3.9V$	$V_{DD}-0.1$	$V_{DD}-0.02$	-	V
OD Pin Output "L" Voltage	V_{DL}	$I_{ol}=-30\mu A, V_{DD}=2.0V$	-	0.1	0.5	V
OC Pin Output "H" Voltage	V_{CH}	$I_{oh}=-30\mu A, V_{DD}=3.9V$	$V_{DD}-0.1$	$V_{DD}-0.02$	-	V

OC Pin Output "L" Voltage	V_{CL}	$I_{ol}=30\mu A, V_{DD}=4.5V$	-	0.1	0.5	V
---------------------------	----------	-------------------------------	---	-----	-----	---

Table 8 Electrical Characteristics ($V_{SS}=0V, T_a=-20\sim 60^\circ C$ unless otherwise specified)

Item	Symbol	Condition	Min.	Typ.	Max.	Unit
SUPPLY POWER RANGE						
Operating voltage between VDD pin and VSS pin	V_{DSOP1}	-	1.5	-	8	V
INPUT CURRENT						
Supply Current	I_{DD}	$V_{DD}=3.9V$	-	4.0	8.7	μA
Power down Current	I_{PD}	$V_{DD}=2.0V$	-	-	0.12	μA
DETECTION VOLTAGE						
Overcharge Detection Voltage	V_{CU}		V_{CU} -0.025	V_{CU}	V_{CU} 0.025	V
Overcharge Release Voltage	V_{CR}		V_{CR} -0.035	V_{CR}	V_{CR} +0.035	V
Overdischarge Detection Voltage	V_{DL}		V_{DL} -0.040	V_{DL}	V_{DL} +0.040	V
Overdischarge Release Voltage	V_{DR}		V_{DR} -0.040	V_{DR}	V_{DR} +0.040	V
Discharge Overcurrent Detection Voltage	V_{DIP}	$V_{DD}=3.6V, CS=V-$	V_{DIP} $\times 0.83$	V_{DIP}	V_{DIP} $\times 1.17$	mV
Short Circuit Detection Voltage	V_{SIP}	$V_{DD}=3.0V, CS=V-$	0.130	0.180	0.230	V
Charge overcurrent detection voltage	V_{CIP}	$V_{DD}=3.6V, CS=V-$	V_{CIP} $\times 0.83$	V_{CIP}	V_{CIP} $\times 1.17$	mV
Maximum Operating Voltage for Inhibition of Charger	V_{nochg}	Voltage Defined as $V_{DD}-V_{SS}, V_{DD}-V=-4V$	0.27	0.7	1.1	V
DELAY TIME						
Overcharge Delay Time	T_{OC}	$V_{DD}=3.9V \rightarrow 4.5V$	670	1000	1550	ms
Overcharge Release Delay Time	T_{CR}	$V_{DD}=4.5V \rightarrow 4.0V$	3	7	11	ms
Overdischarge Delay Time	T_{OD}	$V_{DD}=3.6V \rightarrow 2.0V$	13.4	20	31	ms
Overdischarge Release Delay Time	T_{DR}	$V_{DD}=3.0V, V-=3V \rightarrow 0V$	0.001	0.1	1	ms
Discharge Overcurrent Delay Time	T_{DIP}	$V_{DD}=3.6V, CS=V-=0.4V$	7.5	12	18.6	ms
Discharge Release Overcurrent Delay Time	T_{DIR}	$V_{DD}=3.6V, CS=V-=3V \rightarrow 0V$	3	7	11	ms
Charge Overcurrent Delay Time	T_{CIP}	$V_{DD}=3.6V, CS=V-=0.3V$	10.7	16	24.8	ms
Charge Overcurrent Release Delay Time	T_{CIR}	$V_{DD}=3.6V, CS=V=-1V \rightarrow 0V$	3	7	11	ms
Short Circuit Delay Time	T_{SIP}	$V_{DD}=3.0V, CS=V=-1.3V$	160	250	490	μs
Short Circuit Release Delay Time	T_{SIR}	$V_{DD}=3.6V, CS=V=-1V \rightarrow 0V$	3	7	11	ms
CONTROL OUTPUT VOLTAGE(OD&OC)						
OD Pin Output "H" Voltage	V_{DH}	$I_{oh}=-30\mu A, V_{DD}=3.9V$	$V_{DD}-0.1$	$V_{DD}-0.02$	-	V
OD Pin Output "L" Voltage	V_{DL}	$I_{ol}=-30\mu A, V_{DD}=2.0V$	-	0.1	0.5	V
OC Pin Output "H" Voltage	V_{CH}	$I_{oh}=-30\mu A, V_{DD}=3.9V$	$V_{DD}-0.1$	$V_{DD}-0.02$	-	V
OC Pin Output "L" Voltage	V_{CL}	$I_{ol}=30\mu A, V_{DD}=4.5V$	-	0.1	0.5	V

Note: Since products are not screened at high and low temperature, the specification for this temperature range is guaranteed by design, not tested in production.

Table 9 Electrical Characteristics (VSS=0V, Ta=-40~85°C unless otherwise specified)

Item	Symbol	Condition	Min.	Typ.	Max.	Unit
SUPPLY POWER RANGE						
Operating voltage between VDD pin and VSS pin	V_{DSOP1}	-	1.5	-	8	V
INPUT CURRENT						
Supply Current	I_{DD}	$V_{DD}=3.9V$	-	4.0	8.7	μA
Power down Current	I_{PD}	$V_{DD}=2.0V$	-	-	0.12	μA
DETECTION VOLTAGE						
Overcharge Detection Voltage	V_{CU}		V_{CU} -0.035	V_{CU}	V_{CU} 0.035	V
Overcharge Release Voltage	V_{CR}		V_{CR} -0.043	V_{CR}	V_{CR} +0.035	V
Overdischarge Detection Voltage	V_{DL}		V_{DL} -0.043	V_{DL}	V_{DL} +0.040	V
Overdischarge Release Voltage	V_{DR}		V_{DR} -0.043	V_{DR}	V_{DR} +0.040	V
Discharge Overcurrent Detection Voltage	V_{DIP}	$V_{DD}=3.6V, CS=V-$	V_{DIP} X0.8	V_{DIP}	V_{DIP} X1.2	mV
Short Circuit Detection Voltage	V_{SIP}	$V_{DD}=3.0V, CS=V-$	0.130	0.180	0.230	V
Charge overcurrent detection voltage	V_{CIP}	$V_{DD}=3.6V, CS=V-$	V_{CIP} X0.8	V_{CIP}	V_{CIP} X1.2	mV
Maximum Operating Voltage for Inhibition of Charger	V_{nochg}	Voltage Defined as $V_{DD}-V_{SS}, V_{DD}-V_{-}=4V$	0.27	0.7	1.1	V
DELAY TIME						
Overcharge Delay Time	T_{OC}	$V_{DD}=3.9V \rightarrow 4.5V$	670	1000	1550	ms
Overcharge Release Delay Time	T_{CR}	$V_{DD}=4.5V \rightarrow 4.0V$	3	7	12	ms
Overdischarge Delay Time	T_{OD}	$V_{DD}=3.6V \rightarrow 2.0V$	13.4	20	31	ms
Overdischarge Release Delay Time	T_{DR}	$V_{DD}=3.0V, V_{-}=3V \rightarrow 0V$	0.001	0.1	1	ms
Discharge Overcurrent Delay Time	T_{DIP}	$V_{DD}=3.6V, CS=V-=0.4V$	7.5	12	18.6	ms
Discharge Release Overcurrent Delay Time	T_{DIR}	$V_{DD}=3.6V, CS=V-=3V \rightarrow 0V$	3	7	12	ms
Charge Overcurrent Delay Time	T_{CIP}	$V_{DD}=3.6V, CS=V-=0.3V$	10.7	16	24.8	ms
Charge Overcurrent Release Delay Time	T_{CIR}	$V_{DD}=3.6V, CS=V-=1V \rightarrow 0V$	3	7	12	ms
Short Circuit Delay Time	T_{SIP}	$V_{DD}=3.0V, CS=V-=1.3V$	160	250	490	μs
Short Circuit Release Delay Time	T_{SIR}	$V_{DD}=3.6V, CS=V-=1V \rightarrow 0V$	3	7	12	ms
CONTROL OUTPUT VOLTAGE(OD&OC)						
OD Pin Output "H" Voltage	V_{DH}	$I_{oh}=-30\mu A, V_{DD}=3.9V$	$V_{DD}-0.1$	$V_{DD}-0.02$	-	V
OD Pin Output "L" Voltage	V_{DL}	$I_{ol}=-30\mu A, V_{DD}=2.0V$	-	0.1	0.5	V
OC Pin Output "H"	V_{CH}	$I_{oh}=-30\mu A, V_{DD}=3.9V$	$V_{DD}-0.1$	$V_{DD}-0.02$	-	V

Voltage						
OC Pin Output "L" Voltage	V_{CL}	$I_{ol}=30\mu A, V_{DD}=4.5V$	-	0.1	0.5	V

Note: Since products are not screened at high and low temperature, the specification for this temperature range is guaranteed by design, not tested in production.

10. Test condition and circuit

10.1. Test condition

10.1.1. Supply Current(Test circuit 1)

Set $V1=3.9V$ (DC power supply provided), closing switch S. DMM's μA current gear readings is the supply current.

10.1.2. Power down Current (Test circuit 1)

Set $V1=2.0V$ (DC power supply provided), disconnect switch S. DMM's μA current gear readings is the power down current.

10.1.3. Overcharge Detection Voltage, Overcharge Release Voltage (Test circuit 2)

Digital multimeter voltage profile detection OC terminal voltage. Adjust $V1$, from 4.0V up gradually, every step 1mV, until VOC changed by high low, $V1$ voltage at this time is the overcharge detection voltage; then, gradually adjusting $V1$ down, every step 1mV, until VOC changed by low high, this time $V1$ voltage is overcharge release voltage.

10.1.4. Overdischarge Detection Voltage, Overdischarge Release Voltage (Test circuit 2)

Digital multimeter voltage profile detection OD terminal voltage. Adjust $V1$, from 3.2V down gradually, every step 1mV, until VOD changed by high low, $V1$ voltage at this time is the overdischarge detection voltage; then, gradually adjusting $V1$ up, every step 1mV, until VOD changed by low high, this time $V1$ voltage is overdischarge release voltage .

10.1.5. Discharge Overcurrent Detection Voltage (Test circuit 3)

Set $V1=3.6V, V-=0V$, Digital multimeter voltage profile detection OD terminal voltage. Adjust VCS, gradually upward from 0mV, every step 1mV, until VOD changed by high low, VCS voltage at this time is the discharge overcurrent detection voltage.

10.1.6. Short Circuit Detection Voltage (Test circuit 3)

Set $V1=3.0V, V-=VCS$, Digital multimeter voltage profile detection OD terminal voltage. Adjust $V-$, gradually upward from 0mV, every step 1mV, until VOD changed by high low, VCS voltage at this time is the short circuit detection voltage.

10.1.7. Charge Overcurrent Detection Voltage (Test circuit 4)

Set $V_1=3.6V$, $V_-=V_{CS}$, Digital multimeter voltage profile detection OC terminal voltage. Adjust V_{CS} , gradually downward from 0mV, every step 1mV, until VOC changed by high low, V_{CS} voltage at this time is the charge overcurrent detection voltage.

10.1.8. Overcharge Delay Time, Overcharge Release Delay Time and Overdischarge Delay Time (Test circuit 5)

Set V_1 from 4.0V (moment 50 μ s) rose to 4.5V, compared VDD and OC terminal waveform by Digital oscilloscope, can be derived overcharge detection delay time; then, V_1 from 4.5V (moment 50 μ s) down to 4.0V, compared VDD and OC terminal waveform by Digital oscilloscope, can be derived overcharge release delay time.

Set V_1 from 3.6V (moment 50 μ s) down to 2.0V, compared VDD and OD terminal waveform by Digital oscilloscope, can be derived overdischarge detection delay time.

10.1.9. Overdischarge Release Delay Time (Test circuit 6)

Set $V_1=2.0V$ (moment 50 μ s) rose to 3.0V, compared VDD and OD terminal waveform by Digital oscilloscope, can be derived overdischarge release delay time.

10.1.10. Discharge Overcurrent Delay Time、Discharge Overcurrent Release Delay Time (Test circuit 6/7)

Set $V_1=3.6V$, $V_{CS}=V_-$ from 0V (moment 50 μ s) rose to 0.1V, compared VDD and OD terminal waveform by Digital oscilloscope, can be derived discharge overcurrent delay time; then, $V_{CS}=0V$, V_- from 1.5V (moment 50 μ s) down to 0V, compared VDD and OD terminal waveform by Digital oscilloscope, can be derived discharge overcurrent release delay time.

10.1.11. Short Circuit Delay Time , Short Circuit Release Delay Time (Test circuit 8)

Set $V_1=3.0V$, $V_{CS}=V_-$ from 0V (moment 50 μ s) rose to 0.3V, compared V_{CS} and OD terminal waveform by Digital oscilloscope, can be short circuit delay time; then, $V_{CS}=0V$, V_- from 1.5V (moment 50 μ s) down to 0V, compared V_- and OD terminal waveform by Digital oscilloscope, can be derived short circuit release delay time .

10.1.12. Charge Overcurrent Delay Time, Charge Overcurrent Release Delay Time (Test circuit 9)

Set $V_1=3.6V$, $V_{CS}=V_-$ from 0V (moment 50 μ s) down to -0.1V, compared V_{CS} and OC terminal waveform by Digital oscilloscope, can be derived charge overcurrent delay time; then, V_{CS} from -0.1V (moment 50 μ s) rose to 0V, compared VDD and OC terminal waveform by Digital oscilloscope, can be derived charge overcurrent release delay time.

10.1.13. OD Pin Output “H” voltage (Test circuit 10)

Set $V_1=3.9V$, Adjust the adjustable resistor, makes the current meter reading for $30\mu A$, at this time the voltage meter reading is OD Pin Output “H” voltage.

10.1.14. OD Pin Output “L” voltage (Test circuit 11)

Set $V_1=2.0V$, Adjust the adjustable resistor, makes the current meter reading for $30\mu A$, at this time the voltage meter reading is OD Pin Output “L” voltage.

10.1.15. OC Pin Output “H” voltage (Test circuit 12)

Set $V_1=3.9V$, Adjust the adjustable resistor, makes the current meter reading for $30\mu A$, at this time the voltage meter reading is OC Pin Output “H” voltage.

10.1.16. OC Pin Output “L” voltage (Test circuit 13)

Set $V_1=4.5V$, Adjust the adjustable resistor, makes the current meter reading for $30\mu A$, at this time the voltage meter reading is OC Pin Output “L” voltage.

10.2. Test circuit

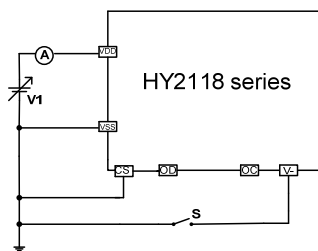

Test circuit 1

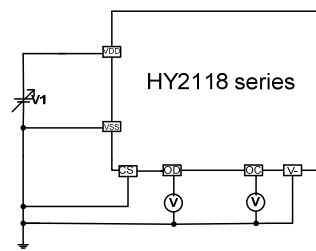

Test circuit 2

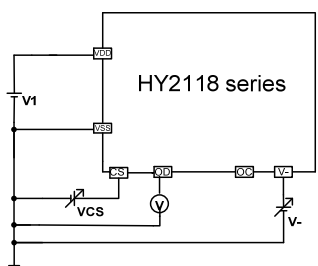

Test circuit 3

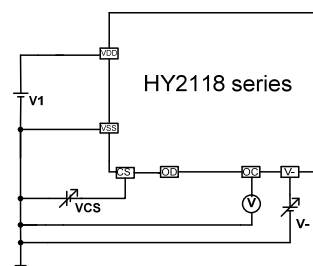

Test circuit 4

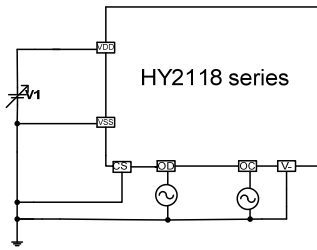

Test circuit 5

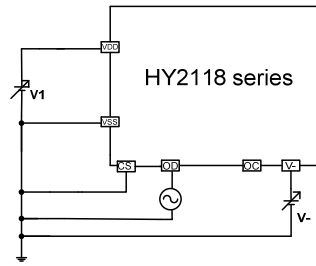

Test circuit 6

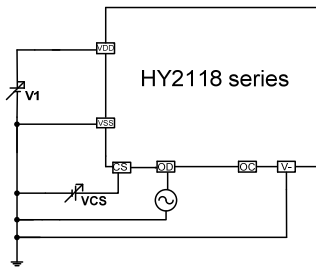

Test circuit 7

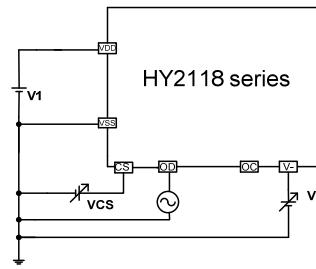

Test circuit 8

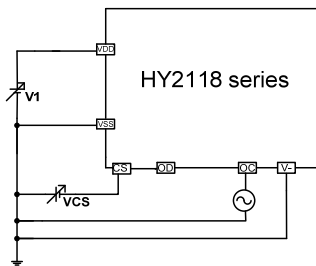

Test circuit 9

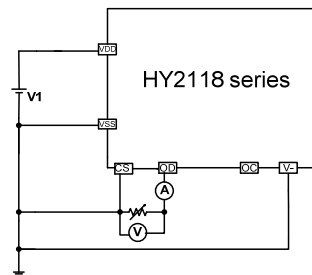

Test circuit 10

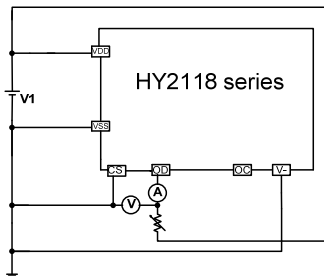

Test circuit 11

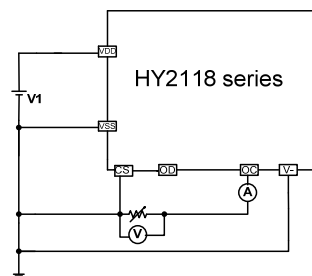

Test circuit 12

HY2118

1-Cell Lithium-ion/Lithium Polymer Battery Packs Protection ICs

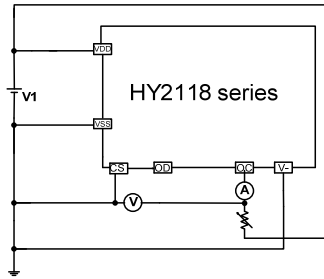

Test circuit 13

11. Example of Battery Protection IC Connection

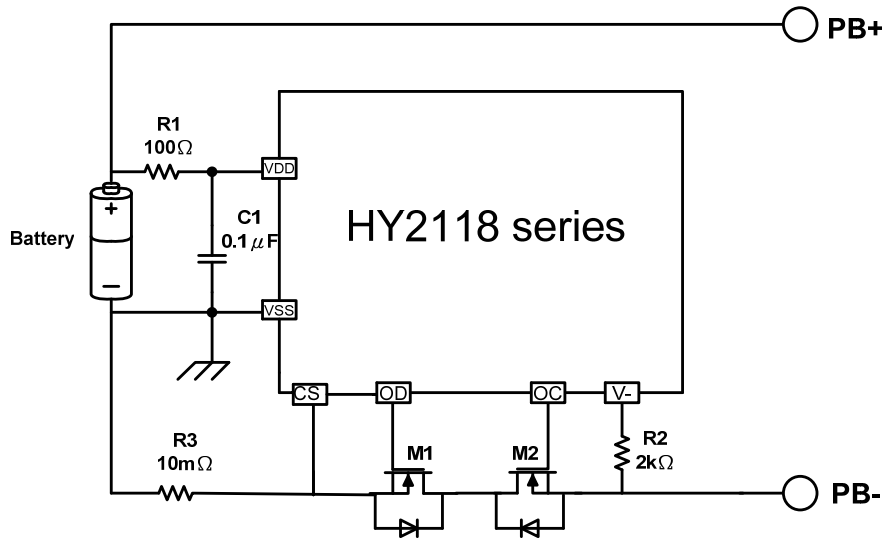

Symbol	Device Name	Purpose	Min.	Typ.	Max.	Remark
R1	Resistor	limit current, stabilize VDD and strengthen ESD protection	100Ω	100Ω	330Ω	*1
R2	Resistor	limit current	1kΩ	2kΩ	2kΩ	*2
R3	Resistor	Sense current	3mΩ	10mΩ	30mΩ	
C1	Capacitor	stabilize VDD	0.01μF	0.1μF	1.0μF	*3
M1	N-MOSFET	Discharge control	-	-	-	*4
M2	N-MOSFET	Charge control	-	-	-	*5

- *1. R1 should be as small as possible to avoid lowering the overcharge detection accuracy due to current consumption. When a charger is connected in reversed, the current flows from the charger to the IC. At this time, if R1 is connected to high resistance, the voltage between VDD pin and VSS pin may exceed the absolute maximum rating.
- *2. If R2 has a resistance higher than 2kΩ, the charging current may not be cut when a high-voltage charger is connected. Please select as large a resistance as possible to prevent current when a charger is connected in reversed.
- *3. C1 will stabilize the supply voltage of VDD, the value of C1 should be equal to or more than 0.01μF.
- *4. If a FET with a threshold voltage equal to or higher than the overdischarge detection voltage is applied, discharging may be stopped before overdischarge is detected.
- *5. If the withstanding voltage between the gate and source is lower than the charger voltage, the FET may be destroyed.

Caution :

1. The above constants may be changed without notice , please download the most up-to-date datasheet on our website. <http://www.hycontek.com>
2. It is advised to perform thorough evaluation and test if peripheral devices need to be adjusted.

12. Description of Operation

12.1. Normal Status

This IC monitors the voltage of the battery connected between the VDD pin and VSS pin and the voltage difference between the CS pin and VSS pin to control charging and discharging.

When the battery voltage is in the range from overdischarge detection voltage (V_{DL}) to overcharge detection voltage (V_{CU}), and the CS pin voltage is in the range from the charge overcurrent detection voltage (V_{CIP}) to discharge overcurrent detection voltage (V_{DIP}), the IC turns both the charging and discharging control MOSFET on. This condition is called the normal status. Under this condition, charging and discharging can both be carried out freely.

Notice:

Discharging may not be enacted when the battery is first time connected. To regain normal status, V- pin and VSS pin must be shorted or the charger must be connected.

12.2. Overcharge Status

Under the normal status, as soon as the battery voltage becomes higher than the overcharge detection voltage (V_{CU}) during charging and the detection continues longer than the overcharge detection delay time (T_{OC}), the HY2118 series will turn the charging control MOSFET off (OC pin) to stop charging. This condition is called the overcharge status.

The overcharge status can be released by the following two cases:

Condition: disconnect charger

(1) The voltage of the battery cell is equal to or lower than the overcharge release voltage (V_{CR}) due to self-discharge.

(2) When the load is connected, the discharge current will pass through parasitical diode of charging control MOSFET. At this time, CS pin will detect "Diode forward voltage drop (V_f)". When CS pin voltage rises higher than discharge overcurrent detection voltage (V_{DIP}) and battery voltage lowers than overcharge detection voltage (V_{CU}), the overcharge status will be released and back to normal status.

Caution:

When a charger is connected after overcharge detection, the overcharge status is not released even if the battery voltage is below overcharge release voltage (V_{CR}). The overcharge status is released when the CS pin voltage goes over 0.15V by removing the charger.

12.3. Overdischarge Status

When the battery voltage falls below than the overdischarge detection voltage (V_{DL}) during discharging in the normal status and the detection continues longer than the overdischarge detection delay time (T_{OD}), the HY2118 series will turn the discharging control MOSFET off (OD pin) so as to stop discharging. This condition is called the overdischarge status.

The overdischarge status will be released by two cases:

- (1) When V- pin voltage is equal to or lower than -0.15V by charging and the VDD pin voltage is higher than the overdischarge detection voltage (V_{DL}).
- (2) When CS pin voltage is equal to or higher than -0.15V by charging and the VDD pin voltage is higher than the overdischarge release voltage (V_{DR}).

12.4. Discharge Overcurrent Status (Discharge Overcurrent & Short Circuit)

Under normal condition, the HY2118 continuously monitors the discharge current by sensing the voltage of CS pin. If the voltage of CS pin exceeds the overcurrent detection voltage (V_{DIP}) and the condition lasts beyond the overcurrent delay time (T_{DIP}), discharging will be suspended by turning off the discharge control MOSFET (OD pin). This condition is called the discharge overcurrent status.

If the voltage of CS pin exceeds the short circuit detection voltage (V_{SIP}) and the condition lasts beyond the short circuit delay time (T_{SIP}), discharging will be suspended by turning off the discharge control MOSFET (OD pin). This condition is called the short circuit status.

When the impedance between PB+ and PB- is higher than discharge overcurrent and short circuit release impedance (45k Ω typ.), the discharge overcurrent status and short circuit status will be released and back to normal operation status. In addition, if the impedance between PB+ and PB- is less than discharge overcurrent and short circuit release impedance, V- pin voltage will descend below than overcurrent detection voltage (V_{DIP}) after the charger is being connected, discharge overcurrent status and short circuit status will be released and back to normal operation status.

Caution:

- (1) If the charger is connected incautiously in reversed, the current direction is the same as discharge current in the circuit. If CS pin voltage goes higher than overcurrent detection voltage (V_{DIP}), it will enter into discharge overcurrent protection status to block out in-circuit current.

12.5. Charge Overcurrent Status

When a battery is in the normal status, the voltage of the CS pin is lower than the charge overcurrent detection voltage (V_{CIP}). When the charge current is higher than the specified value and the status lasts beyond the charge overcurrent detection delay time (T_{CIP}), the charge control MOSFET will be turned off and charging is stopped. This status is called the charge overcurrent status.

This IC will be restored to the normal status from the charge overcurrent status when the voltage at the V- pin returns to charge overcurrent detection voltage (V_{CIP}) or higher by removing the charger.

12.6. 0V Battery Charging Function “Unavailable”

When a battery that is internally short-circuited (0V battery) is connected, the unavailable 0V charging function will prohibit recharging.

Caution

Some battery providers do not recommend charging for a completely self-discharged battery. Please ask the battery provider to determine whether to enable or prohibit the 0V battery charging function.

13. Timing Chart

(1) Overcharge Detection, Overdischarge Detection

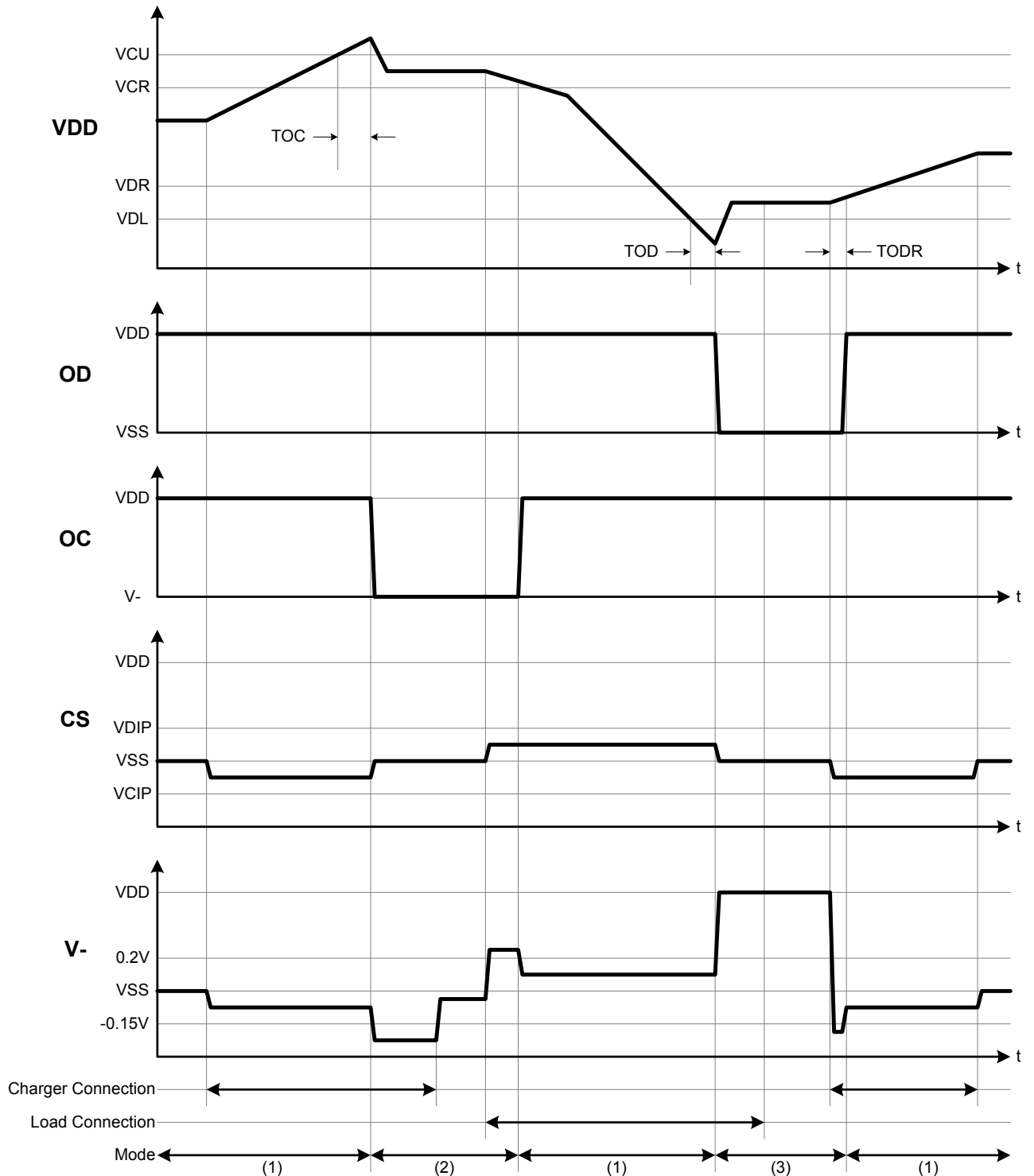

Remark (1) Normal status, (2) Overcharge status, (3) Overdischarge status

Remark:

(a) overcharge release condition: $V_- > 0.2V$ & $VDD < VCU$ ◦

(b) overdischarge release condition: $V_- < -0.15V$ & $VDD > VDL$ ◦

(2) Overcharge Detection, Overdischarge Detection

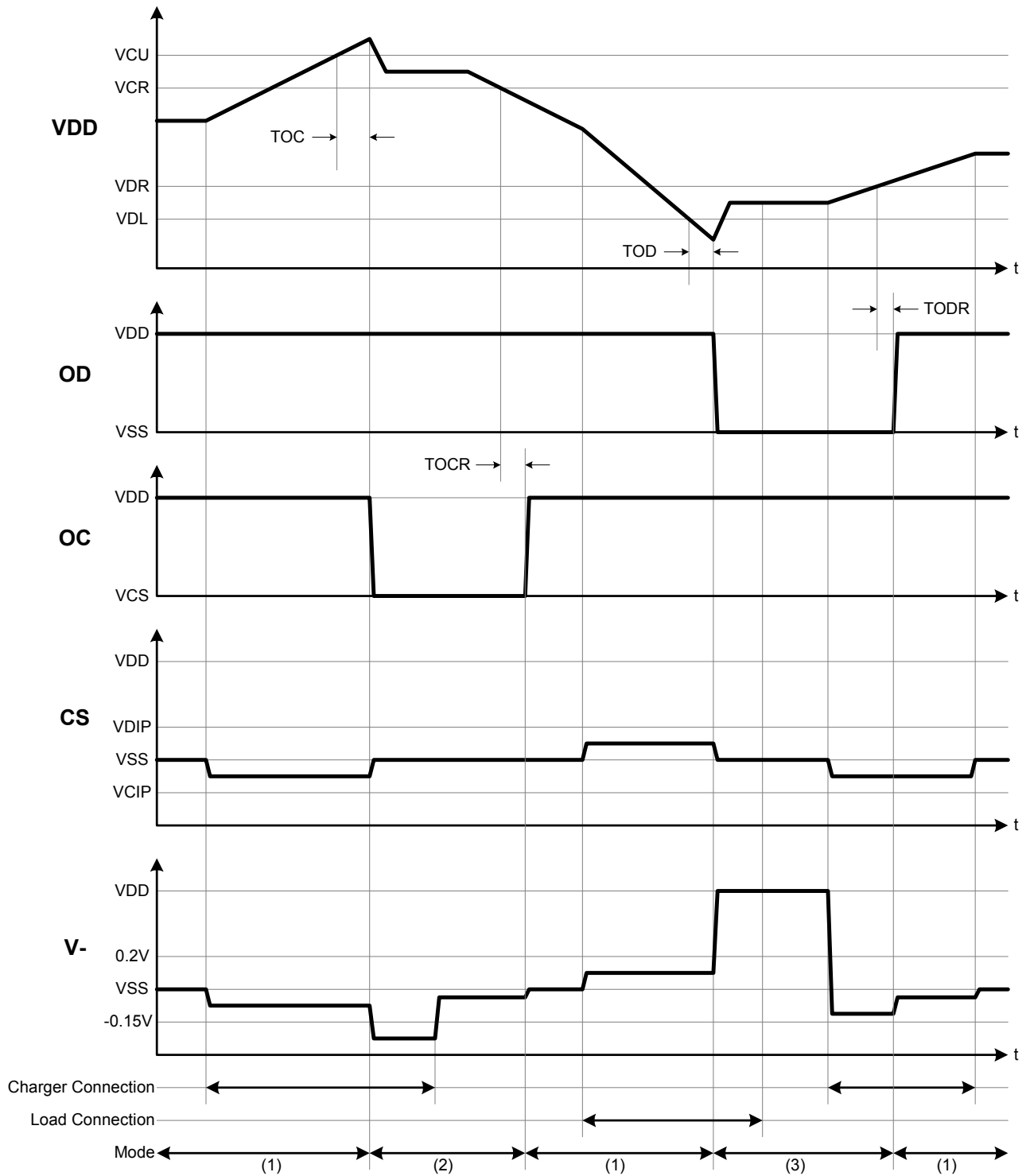

Remark (1) Normal status, (2) Overcharge status, (3) Overdischarge status

Remark:

(a) overcharge release condition: $-0.15V < V- < 0.2V$ & $VDD < VCR$ ◦

(b) overdischarge release condition: $V- > -0.15V$ & $VDD > VDR$ ◦

(3) Discharge overcurrent Detection, Short circuit Detection, Charge overcurrent Detection

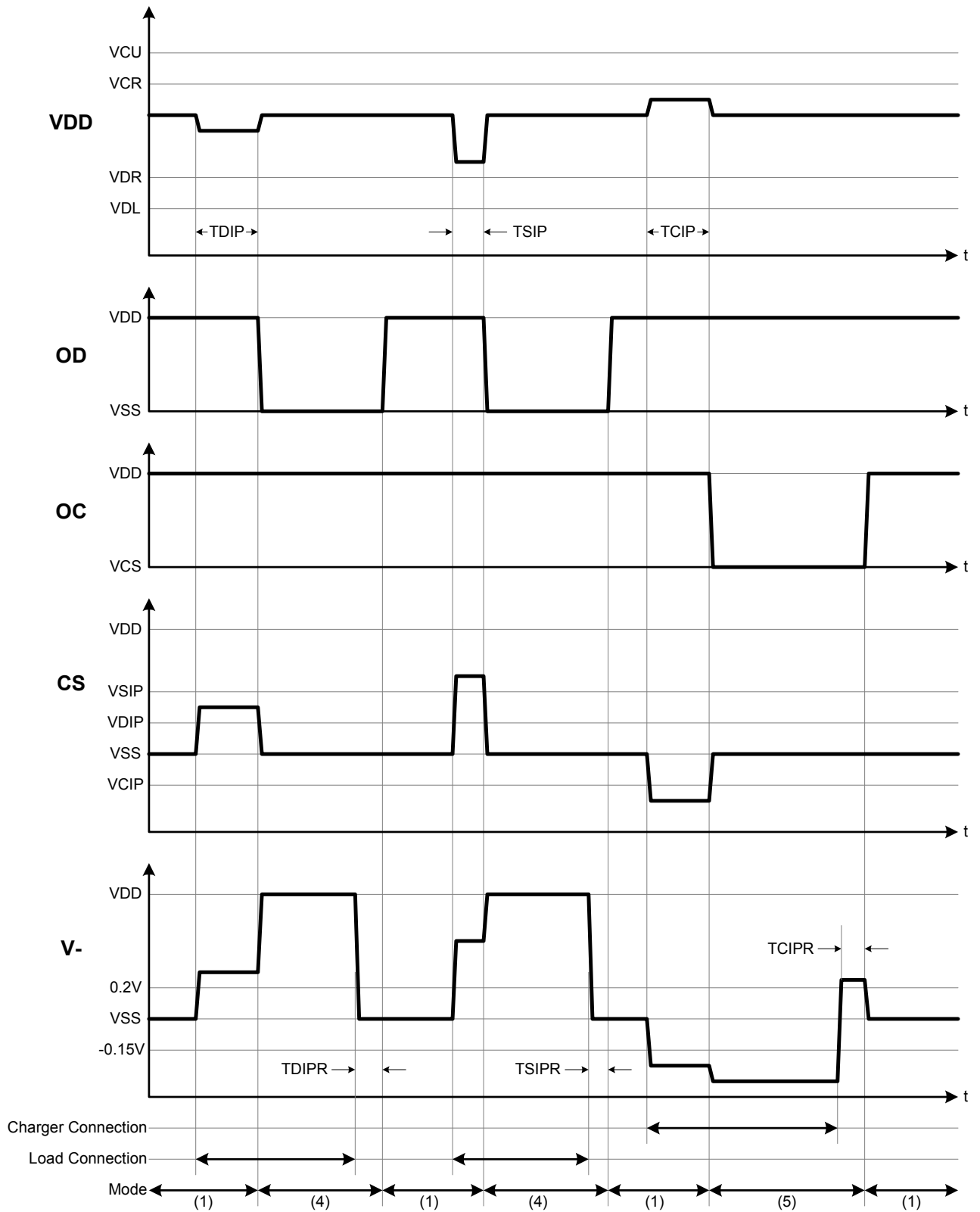

Remark (1) Normal status, (4) Discharge Overcurrent status (Discharge Overcurrent & Short Circuit), (5) Charge Overcurrent status

14. Characteristics (Typical Value)

14.1. Overcharge Detection / Release Voltage, Overdischarge Detection / Release Voltage, Discharge Overcurrent Detection Voltage, Short Circuit Detection Voltage, Charge Overcurrent Detection Voltage and Delay Time.

(1) V_{CU} vs. T_a

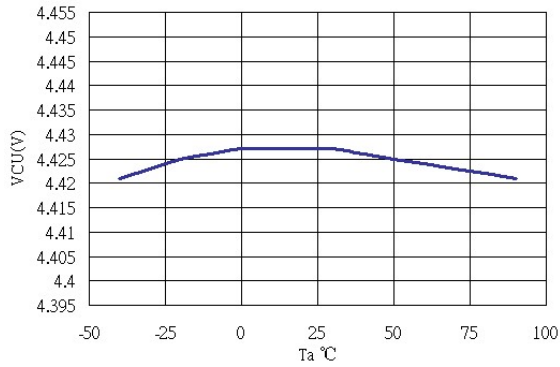

(2) V_{CR} vs. T_a

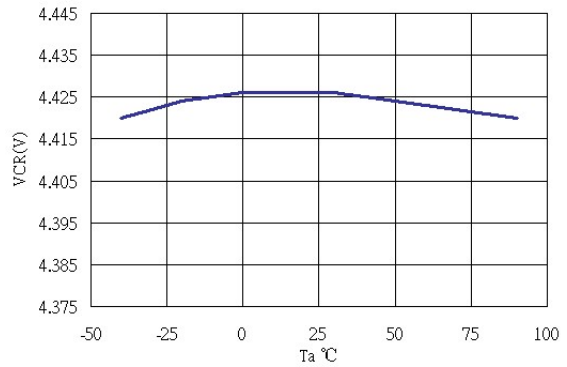

(3) V_{DL} vs. T_a

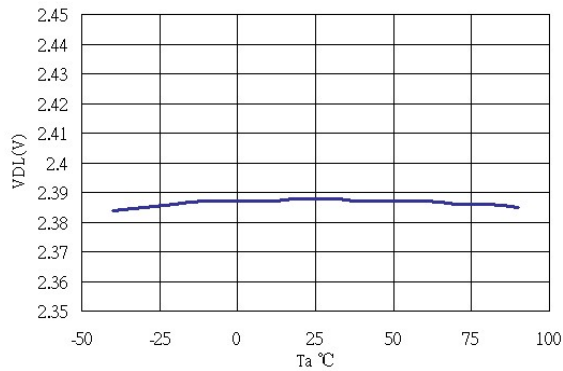

(4) V_{DR} vs. T_a

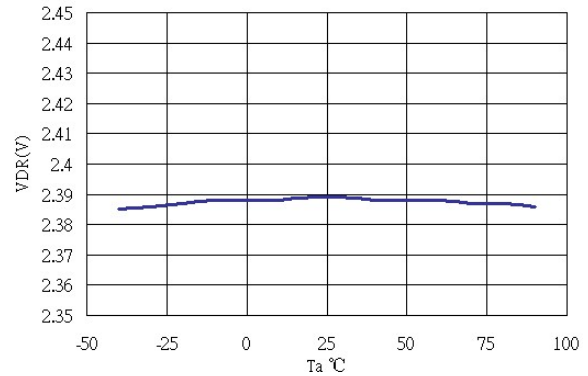

(5) T_{OC} vs. T_a

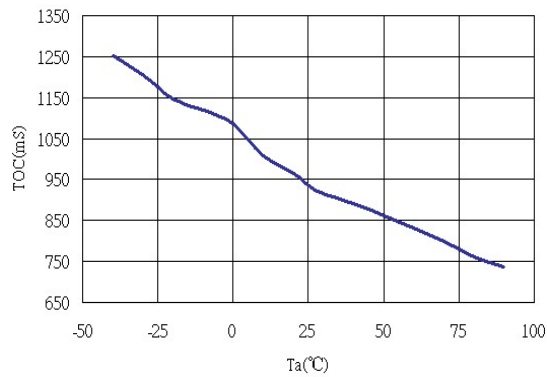

(6) T_{OD} vs. T_a

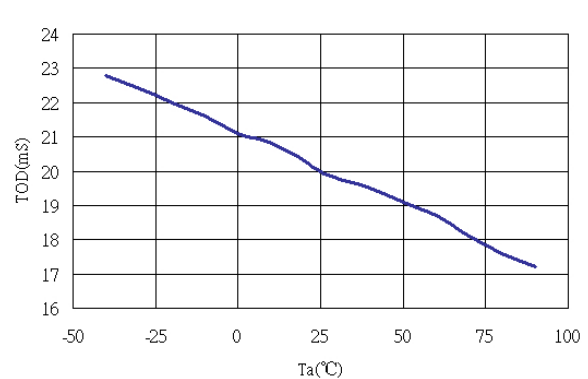

(7) V_{DIP} vs. T_a

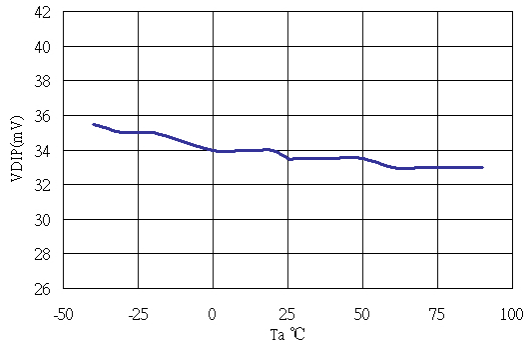

(8) T_{DIP} vs. T_a

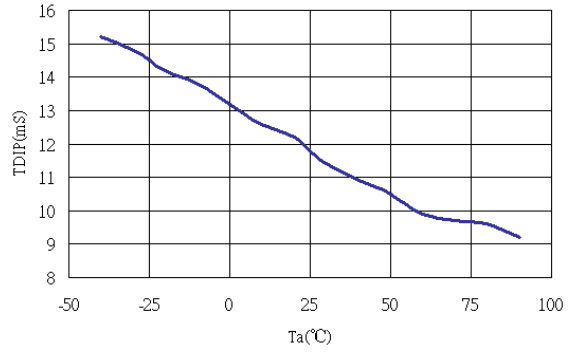

(9) V_{SIP} vs. T_a

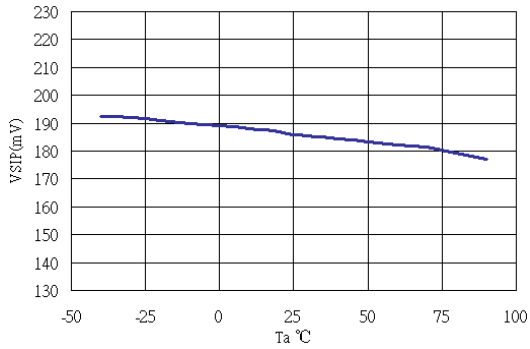

(10) T_{SIP} vs. T_a

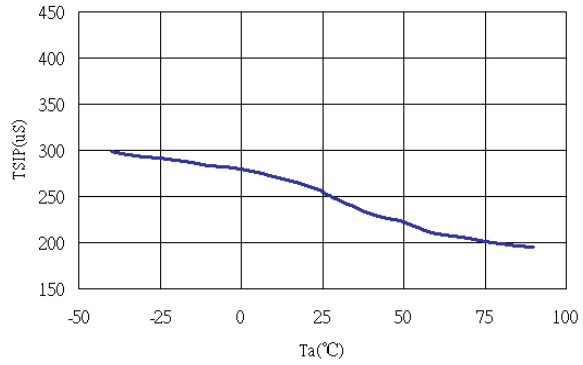

(11) V_{CIP} vs. T_a

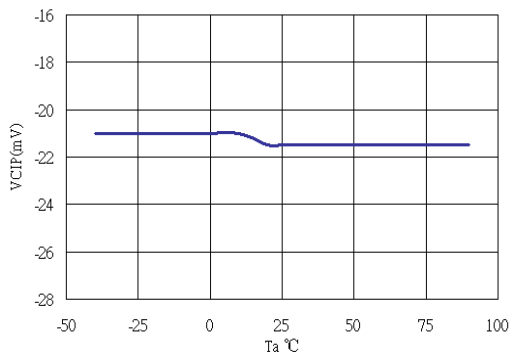

(12) T_{CIP} vs. T_a

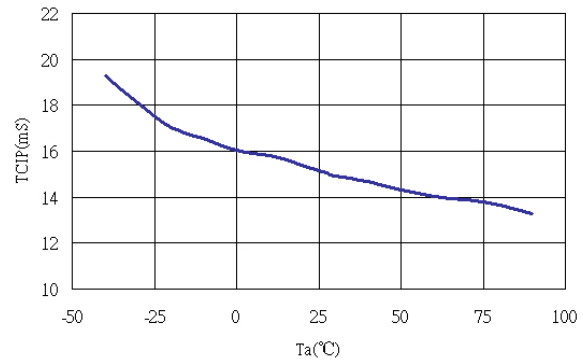

14.2. Current Consumption

(13) I_{DD} vs. T_a

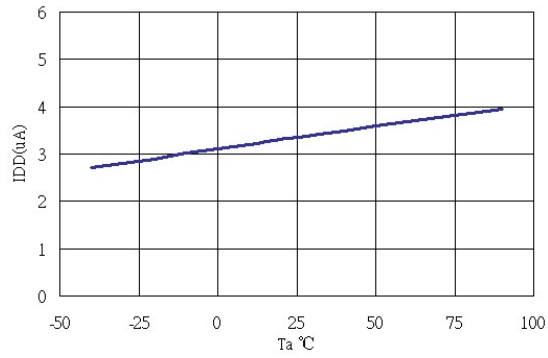

(14) I_{PD} vs. T_a

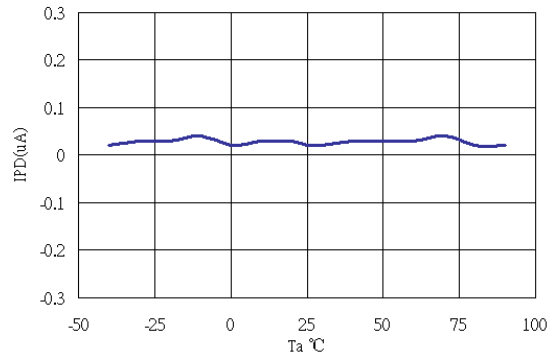

15. Package information and Land Pattern Design Recommendations

15.1. DFN-1.4*1.4-6L and Land Pattern Design Recommendations

15.1.1. DFN-1.4*1.4-6L

Package Outline Drawing---DFN-1.4*1.4-6L

Unit: mm

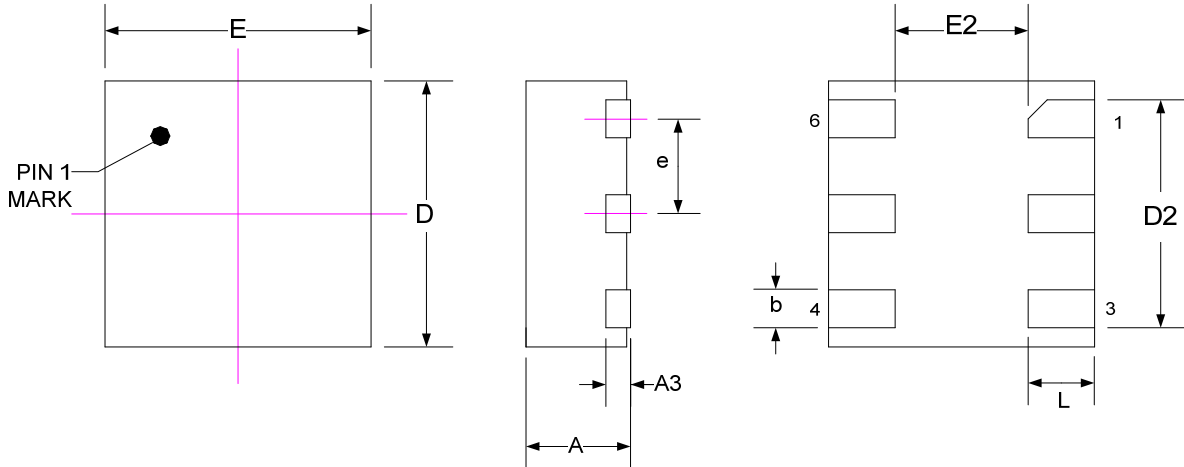

SYMBOLS	MIN	NOM	MAX
A	0.48	0.53	0.58
A3	0.127 REF.		
b	0.18	0.20	0.22
D	1.37	1.40	1.43
E	1.37	1.40	1.43
D2	1.15	1.20	1.25
E2	0.65	0.70	0.75
L	0.30	0.35	0.40
e	0.50 BSC		

15.1.2. Land Pattern Design Recommendations

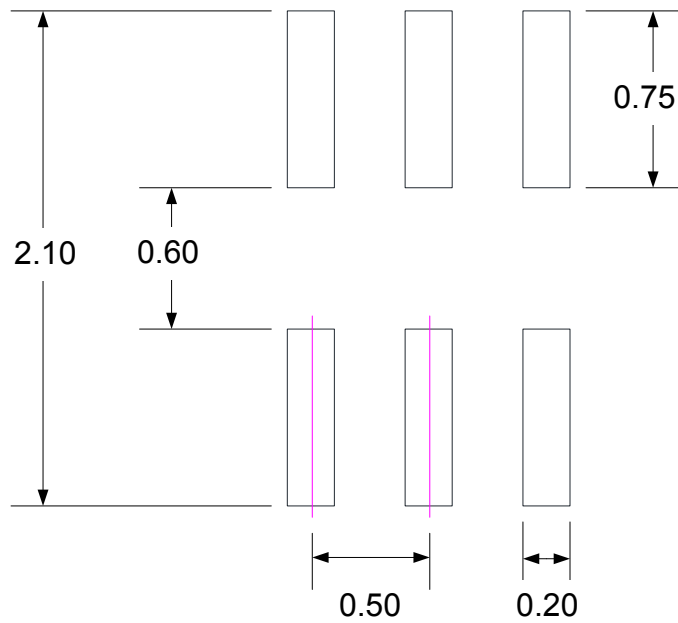

Note:

1. Publication IPC-7351 is recommended for alternate designs.
2. Unit : mm.
3. <http://www.hycontek.com/attachments/MSP/OJTI-HM-2013-002.pdf>.

15.2. DFN-1.4*1.4-6L-EP and Land Pattern Design Recommendations

15.2.1. DFN-1.4*1.4-6L-EP

Package Outline Drawing--- DFN 1.4x1.4-6L-EP

Unit : mm

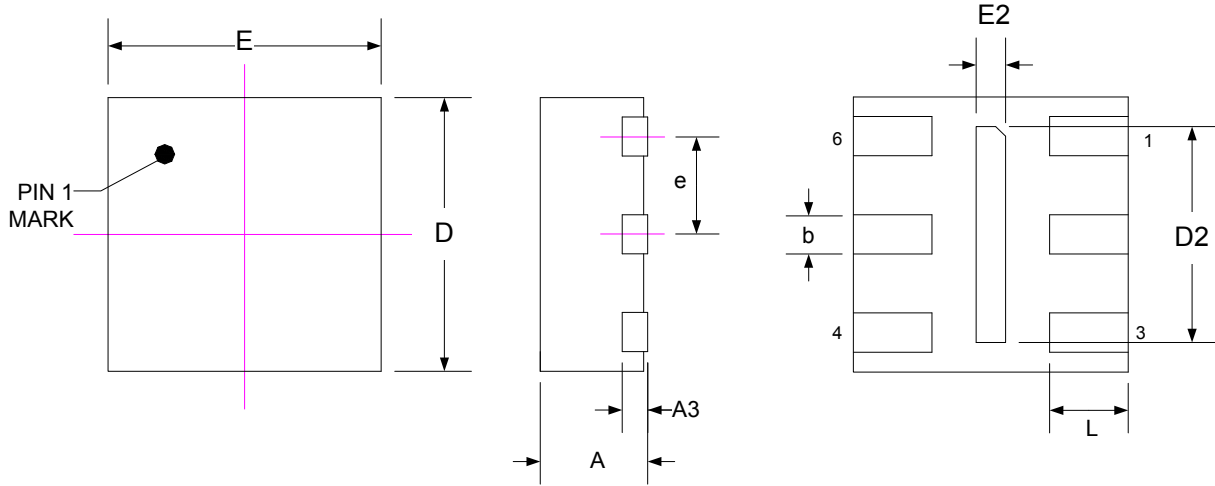

SYMBOLS	MIN	NOM	MAX
A	0.48	0.53	0.58
A3	0.127 REF.		
b	0.18	0.20	0.22
D	1.35	1.40	1.45
E	1.35	1.40	1.45
D2	1.05	1.10	1.15
E2	0.10	0.15	0.20
L	0.35	0.40	0.45
e	0.50 BSC		

15.2.2. Land Pattern Design Recommendations

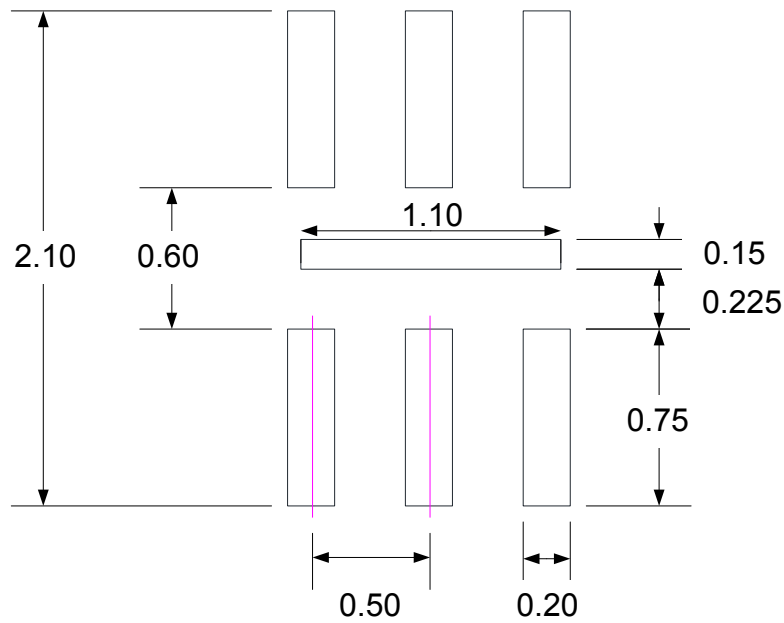

Note:

1. Publication IPC-7351 is recommended for alternate designs.
2. Unit : mm.
3. <http://www.hycontek.com/attachments/MSP/OJTI-HM-2013-002.pdf>.

16. Tape & Reel information

16.1. Tape & Reel information—DFN-1.4*1.4-6L and DFN-1.4*1.4-6L-EP

16.1.1. Reel Dimensions

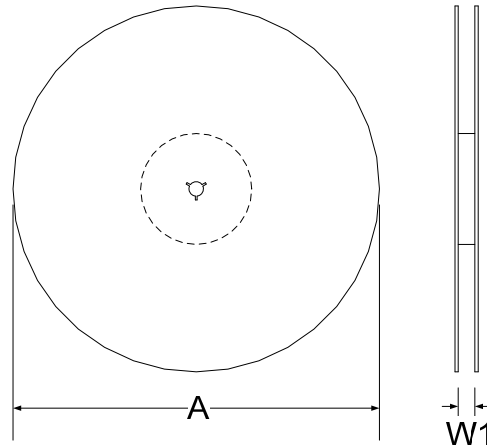

16.1.2. Carrier Tape Dimensions

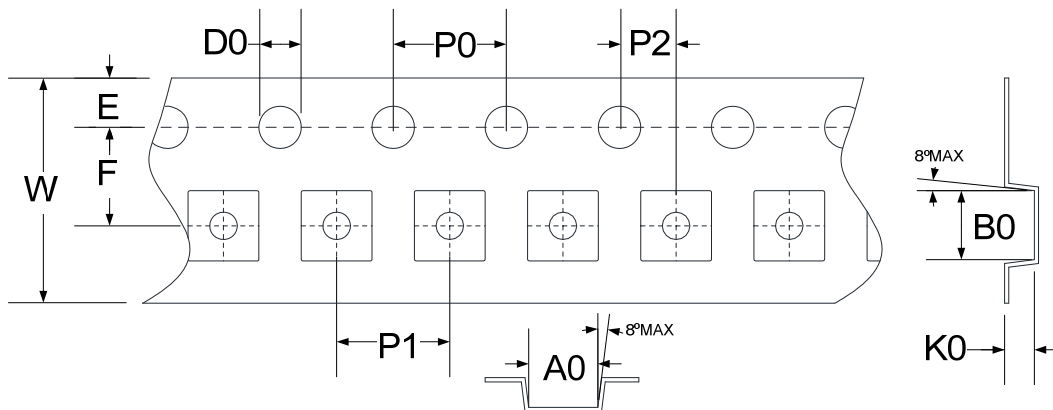

SYMBOLS	Reel Dimensions		Carrier Tape Dimensions									
	A	W1	A0	B0	K0	P0	P1	P2	E	F	D0	W
Spec.	178	9.4	1.55	1.55	0.65	4.00	4.00	2.00	1.75	3.50	1.55	8.00
Tolerance	±2.00	±1.50	±0.05	±0.05	±0.05	±0.10	±0.10	±0.05	±0.10	±0.10	±0.05	+0.30/-0.10

Note:

1. 10 Sprocket hole pitch cumulative tolerance is ±0.20mm.
2. Unit : mm.

17. Revision Record

Major differences are stated thereafter:

Version	Page	Revision Summary
V01	All	First Edition
V02	All	Add in HY2118-XG2J, Delete HY2118-DC2J.
	29	Add in DFN-1.4*1.4-6L-EP package.
	28,30	Add in Land Pattern Design Recommendations.
	31	Add in Tape & Reel information.