



HY12P63
Datasheet
DMM Specialized IC
Embedded Digital T-RMS

Table of Contents

1. FEATURES	5
2. BLOCK DIAGRAM	6
2.1 Multi-Function Block	7
2.2 ADC	8
2.3 Power	9
3. PACKAGE AND PIN	10
3.1 64PIN Diagram LQFP64	10
3.2 Pin Description	11
4. REGISTER LIST	14
5. ABSOLUTE MAXIMUM RATINGS	16
5.1 Recommended Operating Conditions	16
5.2 Internal RC Oscillator	17
5.3 Supply Current into VDD Excluding Peripherals Current	17
5.4 Port 1~2	17
5.5 Reset(Brownout, External RST pin, Low Voltage Detect)	18
5.6 Power System	20
5.7 LCD	20
5.8 $\Sigma\Delta$ ADC, Power Supply and Recommended Operating Conditions	21
5.9 $\Sigma\Delta$ ADC, Temperature Sensor	22
5.10 Analog Input and Switch Performance	22
5.11 DMM Comparator	22

6. ORDERING INFORMATION	23
7. PACKAGING INFORMATION.....	24
8. REVISION RECORD.....	25

Attention :

1. HYCON Technology Corp. reserves the right to change the content of this datasheet without further notice. For most up-to-date information, please constantly visit our website:
<http://www.hycontek.com> .
2. HYCON Technology Corp. is not responsible for problems caused by figures or application circuits narrated herein whose related industrial properties belong to third parties.
3. Specifications of any HYCON Technology Corp. products detailed or contained herein stipulate the performance, characteristics, and functions of the specified products in the independent state. We does not guarantee of the performance, characteristics, and functions of the specified products as placed in the customer's products or equipment. Constant and sufficient verification and evaluation is highly advised.
4. Please note the operating conditions of input voltage, output voltage and load current and ensure the IC internal power consumption does not exceed that of package tolerance. HYCON Technology Corp. assumes no responsibility for equipment failures that resulted from using products at values that exceed, even momentarily, rated values listed in products specifications of HYCON products specified herein.
5. Notwithstanding this product has built-in ESD protection circuit, please do not exert excessive static electricity to protection circuit.
6. Products specified or contained herein cannot be employed in applications which require extremely high levels of reliability, such as device or equipment affecting the human body, health/medical equipments, security systems, or any apparatus installed in aircrafts and other vehicles.
7. Despite the fact that HYCON Technology Corp. endeavors to enhance product quality as well as reliability in every possible way, failure or malfunction of semiconductor products may happen. Hence, users are strongly recommended to comply with safety design including redundancy and fire-precaution equipments to prevent any accidents and fires that may follow.
8. Use of the information described herein for other purposes and/or reproduction or copying without the permission of HYCON Technology Corp. is strictly prohibited.

1. Features

- Operation voltage: 2.5V~3.6V
- 4K Word OTP (One Time Programmable) program memory, 256Byte data memory
- Built-in Brownout and Watch dog timer, preventing CPU from crash
- Built-in high precision RC oscillator
 - Operation mode: 4MHz
 - Idle mode: 32KHz
- Programmable multi-functional network
 - Voltage/resistor switch measurement
 - Constant voltage output
 - Positive/negative electrode differential
- Multi-functional comparator
 - Equipped with delay and latch function, reducing glitch
 - Programmable comparison voltage configuration
 - Short circuit test
- High resolution $\Sigma\Delta$ ADC
 - Zero input/output voltage
 - High input impedance (built-in input buffer)
 - Built-in absolute temperature sensor
- 1.2V internal analog circuit common-ground voltage source
- LVD low voltage detect function equips with 14-step voltage detect configuration and external input voltage detect function
- Analog voltage source, VDDA can set up 4 types of output voltage, equipping with 10mA regulated voltage source output ability
- 4x12 LCD driver
 - Built-in charge pump regulated circuit, providing 4 LCD bias voltage
 - Static, 1/2, 1/3, 1/4 Duty and 1/3 Bias software selection
- 8-bit Timer A
- 8-bit Timer C module can generate PWM/ waveform
- Support 6 stack level

2. Block Diagram

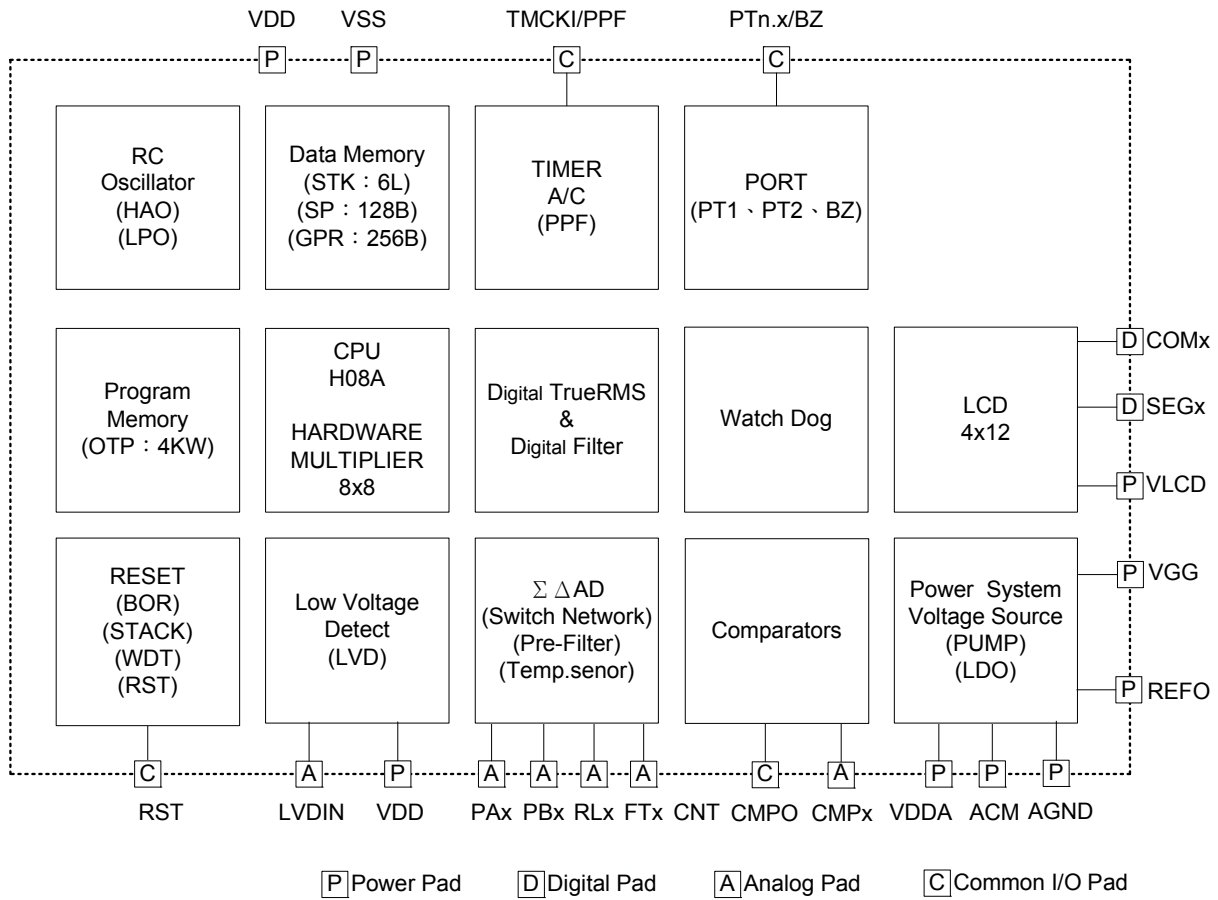

2.1 Multi-Function Block

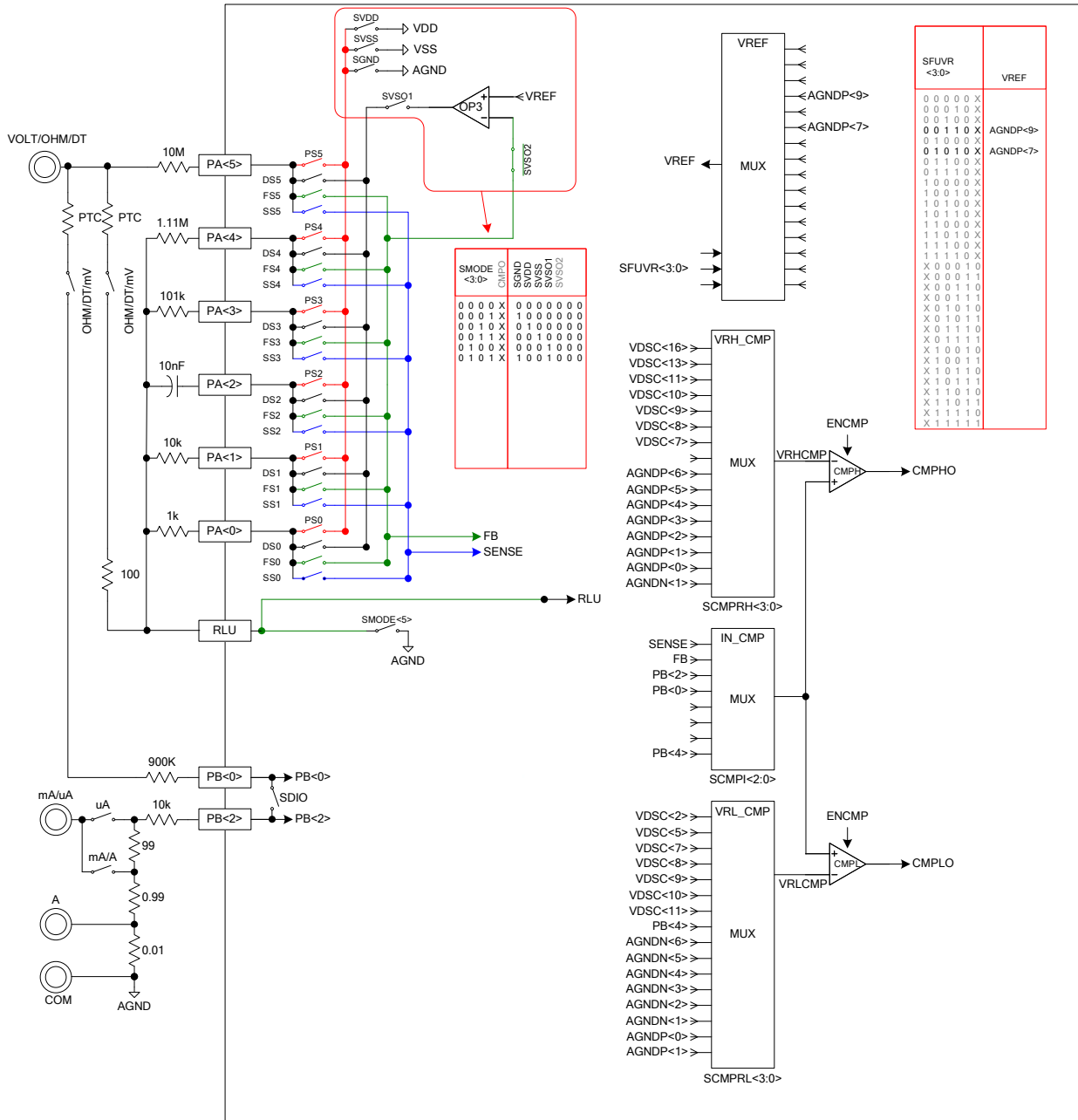

2.2 ADC

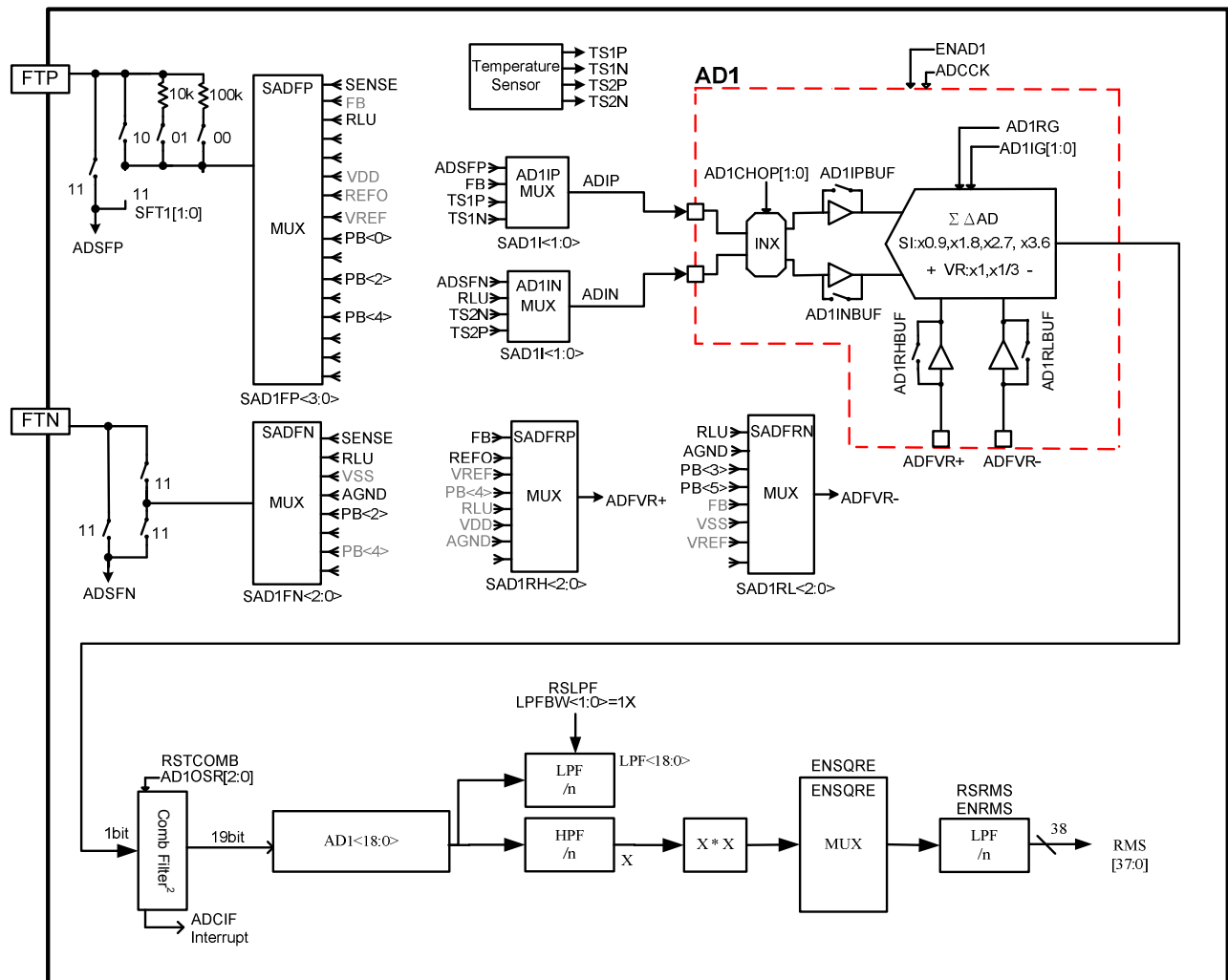

2.3 Power

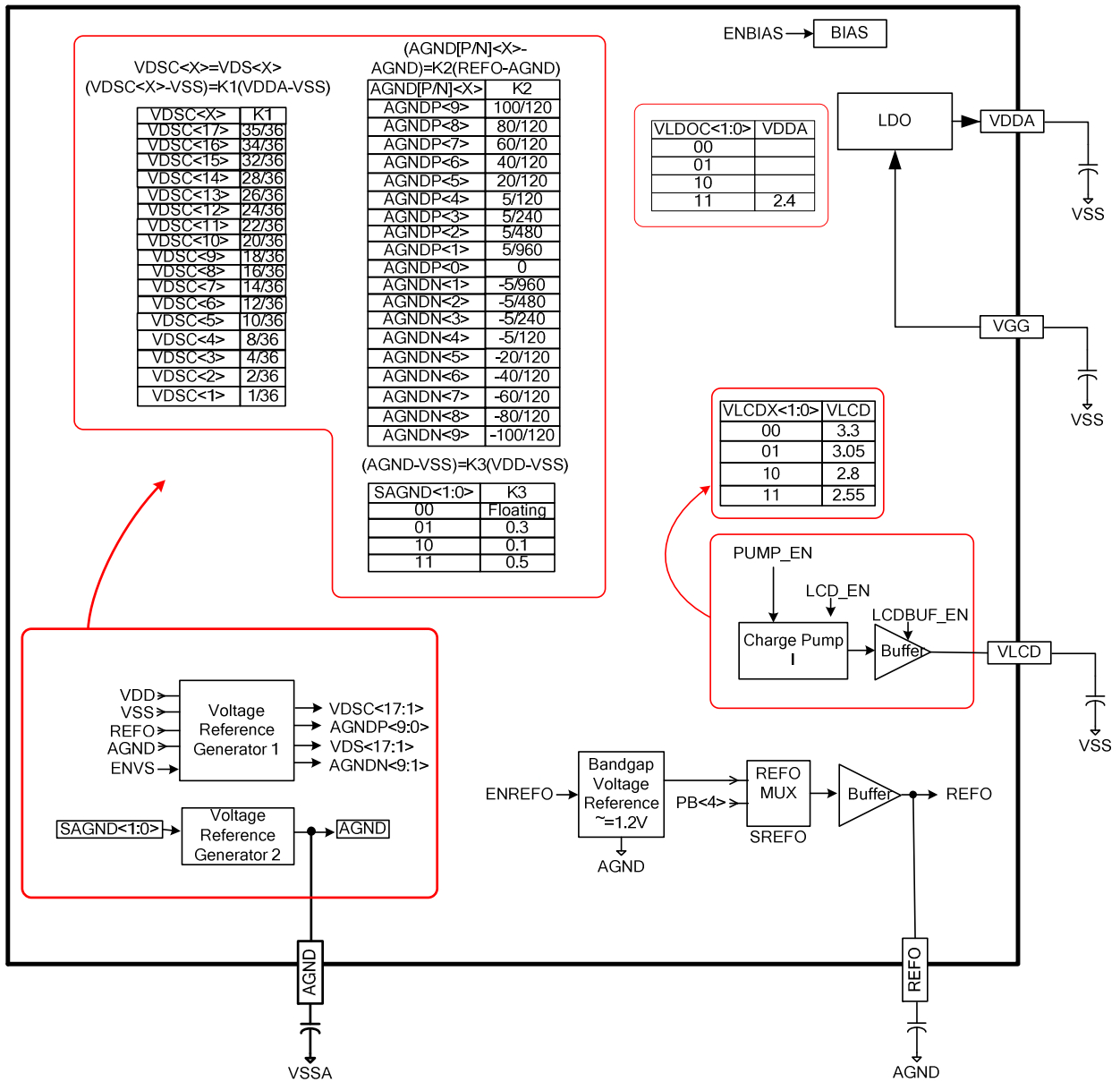

3. Package And Pin

3.1 64PIN Diagram LQFP64

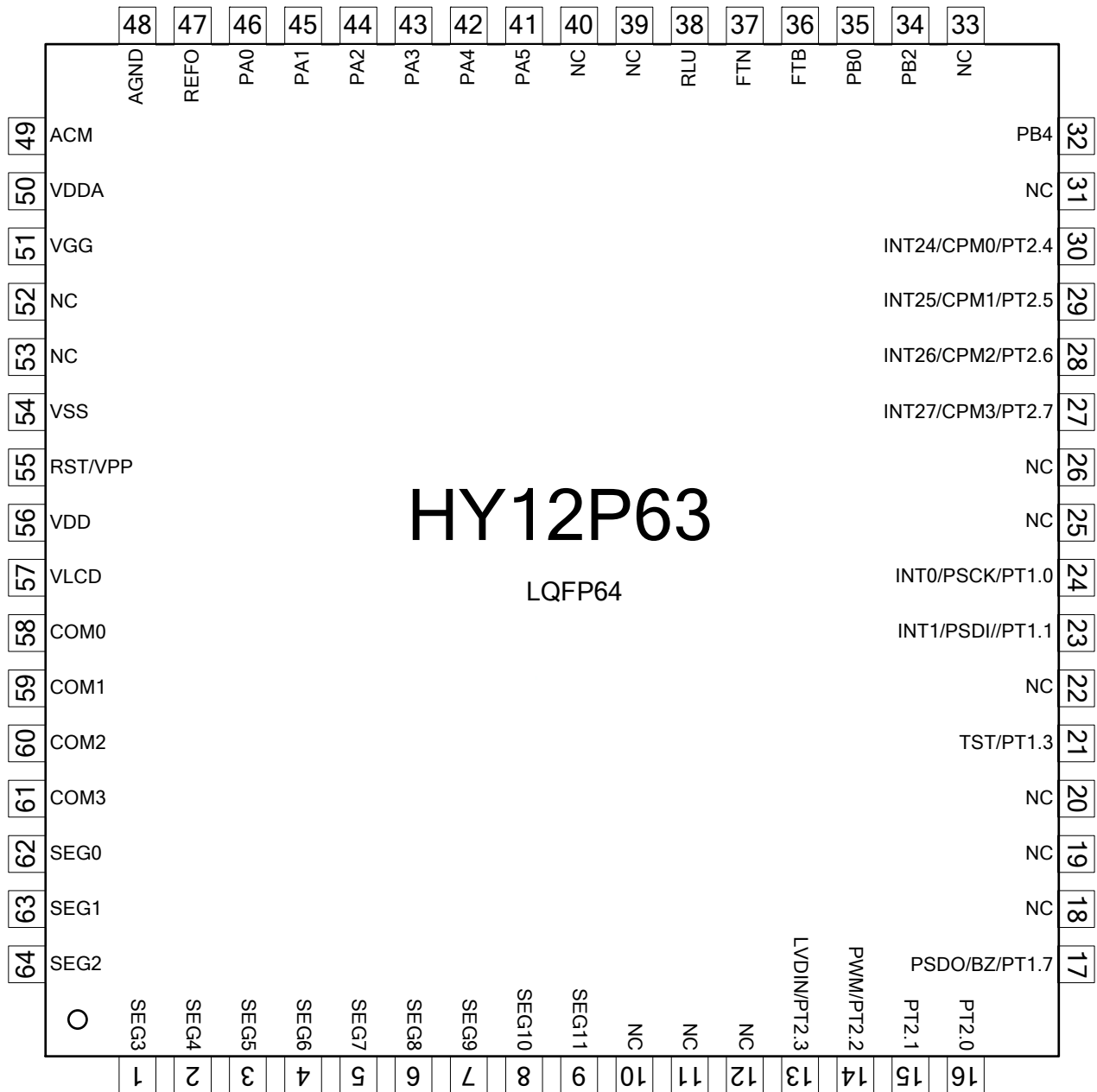

3.2 Pin Description

"I/O" Input/Output, "I" Input, "O" Output, "S" Schmitt Trigger, "C" CMOS, "P" Power, "A" Analog

Pin		Characteristic		Description
No.	Name	I/O	Type	
1	SEG3	O	A	Segment output of LCD
2	SEG4	O	A	Segment output of LCD
3	SEG5	O	A	Segment output of LCD
4	SEG6	O	A	Segment output of LCD
5	SEG7	O	A	Segment output of LCD
6	SEG8	O	A	Segment output of LCD
7	SEG9	O	A	Segment output of LCD
8	SEG10	O	A	Segment output of LCD
9	SEG11	O	A	Segment output of LCD
10	NC			No Connect
11	NC			No Connect
12	NC			No Connect
13	PT2.3/LVDIN	I/O	S	Digital input/output
		I	A	LVD external signal input port
14	PT2.2/PWM	I/O	C	Digital input/output
		O	C	PWM output port
15	PT2.1	I/O	S	Digital input/output
16	PT2.0	I/O	S	Digital input/output
17	PT1.7/BZ/PSDO	I/O	S	Digital input/output
		O	C	Buzzer output port
		O	C	PSDO port of OTP read/write interface
18	NC			No Connect
19	NC			No Connect
20	NC			No Connect
21	PT1.3/TST	I	S	Digital input
		I	S	Enable input of test mode (invalid)
22	NC			No Connect

23	PT1.1/PSDI/INT1	PT1.1	I/O	S	Digital input
		PSDI	I	S	PSDI of OTP read/write interface
		INT1	I	S	Interrupt source, INT1
24	PT1.0/PSCK/INT0	PT1.0	I/O	S	Digital input
		PSCK	I	S	PSCK of OTP read/write interface
		INT0	I	S	Interrupt source, INT0
25	NC				No Connect
26	NC				No Connect
27	PT2.7/CMP3/INT27	PT2.7	I/O	C	Digital input/output
		CMP3	I	A	Input port of comparator
		INT27	I	C	Interrupt source, E27IF
28	PT2.6/CMP2/INT26	PT2.6	I/O	S	Digital input/output
		CMP2	I	A	Input port of comparator
		INT26	I	S	Interrupt source, E26IF
29	PT2.5/CMP1/INT25	PT2.5	I/O	S	Digital input/output
		CMP1	I	A	Input port of comparator
		INT25	I	S	Interrupt source, E25IF
30	PT2.4/CMP0/INT24	PT2.4	I/O	S	Digital input/output
		CMP0	I	A	Input port of comparator
		INT24	I	S	Interrupt source, E24IF
31	NC				No Connect
32	PB4		I	A	Analog input channel
33	NC				No Connect
34	PB2		I	A	Analog input channel
35	PB0		I	A	Analog input channel
36	FTP		I/O	A	Capacitor connect port of pre-filter
37	FTN		I/O	A	Capacitor connect port of pre-filter
38	RLU		I/O	A	Switch of analog network
39	NC				No Connect
40	NC				No Connect
41	PA5		I/O	A	Switch of analog network
42	PA4		I/O	A	Switch of analog network

43	PA3		I/O	A	Switch of analog network
44	PA2		I/O	A	Switch of analog network
45	PA1		I/O	A	Switch of analog network
46	PA0		I/O	A	Switch of analog network
47	REFO		I/O	P	Voltage reference port
48	AGND		I/O	P	Analog power ground end
49	ACM		I/O	P	Voltage reference port
50	VDDA		I/O	P	Analog circuit voltage source
51	VGG		O	P	Charge pump voltage source
52	NC				No Connect
53	NC				No Connect
54	VSS		P	P	Ground end of IC operation voltage source
55	RST/VPP	RST VPP	I P	S P	Reset IC (Low active) EPROM read/write voltage source
56	VDD		P	P	Voltage source of IC operation
57	VLCD		I/O	P	Voltage source of LCD
58	COM0		O	A	COM output of LCD
59	COM1		O	A	COM output of LCD
60	COM2		O	A	COM output of LCD
61	COM3		O	A	COM output of LCD
62	SEG0		O	A	Segment output of LCD
63	SEG1		O	A	Segment output of LCD
64	SEG2		O	A	Segment output of LCD

4. Register list

"0" no use, "1" read/write, "w" write, "r" read, "r0" only read 0, "r1" only read 1, "w0" only write 0, "w1" only write 1														
": "unimplemented bit, "x" unknown, "u" unchanged, "d" depends on condition														
Address	File Name	Bit7	Bit6	Bit5	Bit4	Bit3	Bit2	Bit1	Bit0	A-RESET	I-RESET	R/W		
00H	INDF0	Contents of FSR0 to address data memory value of FSR0 not changed									N/A	N/A	*****	
01H	POINC0	Contents of FSR0 to address data memory value of FSR0 post-incremented									N/A	N/A	*****	
02H	PODEC0	Contents of FSR0 to address data memory value of FSR0 post-decremented									N/A	N/A	*****	
03H	PRINC0	Contents of FSR0 to address data memory value of FSR0 pre-incremented									N/A	N/A	*****	
04H	PLUSW0	Contents of FSR0 to address data memory value of FSR0 offset by W									N/A	N/A	*****	
05H	INDF1	Contents of FSR1 to address data memory value of FSR0 not changed									N/A	N/A	*****	
06H	POINC1	Contents of FSR1 to address data memory value of FSR0 post-incremented									N/A	N/A	*****	
07H	PODEC1	Contents of FSR1 to address data memory value of FSR0 post-decremented									N/A	N/A	*****	
08H	PRINC1	Contents of FSR1 to address data memory value of FSR0 pre-incremented									N/A	N/A	*****	
09H	PLUSW1	Contents of FSR1 to address data memory value of FSR0 offset by W									N/A	N/A	*****	
0FH	FSR0H									FSR0[8]xu	-----*	
10H	FSR0L	Indirect Data Memory Address Pointer 0 Low Byte, FSR0[7:0]									xxxx xxxx	uuuu uuuu	*****	
11H	FSR1H									FSR1[8]xu	-----*	
12H	FSR1L	Indirect Data Memory Address Pointer 1 Low Byte, FSR1[7:0]									xxxx xxxx	uuuu uuuu	*****	
16H	TOSH				TOS[12]	TOS[11]	TOS[10]	TOS[9]	TOS[8]	...0 0000	...0 0000	-----*		
17H	TOSL	Top-of-Stack Low Byte (TOS<7:0>)									0000 0000	0000 0000	*****	
18H	STKPTR	STKFL	STKUN	STKOV			STKPRT[2]	STKPRT[1]	STKPRT[0]	000. 000	000. 000	r,rw0,rw0,-,r,r,f		
1AH	PCLATH				PC[12]	PC[11]	PC[10]	PC[9]	PC[8]	...0 0000	...0 0000	-----*		
1BH	PCLATL	PC Low Byte for PC<7:0>									0000 0000	0000 0000	*****	
1DH	TBLPTRH				TBLPTR[12]	TBLPTR[11]	TBLPTR[10]	TBLPTR[9]	TBLPTR[8]	...0 0000	...0 0000	-----*		
1EH	TBLPTRL	Program Memory Table Pointer Low Byte (TBLPTR<7:0>)									0000 0000	0000 0000	*****	
1FH	TBLDH	Program Memory Table Latch High Byte									0000 0000	0000 0000	*****	
20H	TBLDL	Program Memory Table Latch Low Byte									0000 0000	0000 0000	*****	
21H	PRODH	Product Register of Multiply High Byte									xxxx xxxx	uuuu uuuu	r,r,f,r r,r,f,r	
22H	PRODL	Product Register of Multiply Low Byte									xxxx xxxx	uuuu uuuu	r,r,f,r r,r,f,r	
23H	INTE1	GIE		TMCIE		TMAIE	WDTIE	E1IE	E0IE	0.0. 0000	0.0. 0000	*,-,*****		
24H	INTE2			RMSIE	LPFIE	AD1IE		CTIE		0000 000.	0000 000.	*****,-		
25H	INTE3	E24IE	E25IE	E26IE	E27IE					0000	0000	*****,-		
26H	INTF1			TMCIF		TMAIF	WDTIF	E1IF	E0IF	..0 0000	..0 0000	-----*		
27H	INTF2			RMSIF	LPFIF	AD1IF		CTIF		0000 000.	0000 000.	*****,-		
28H	INTF3	E24IF	E25IF	E26IF	E27IF					0000	0000	*****,-		
29H	WREG	Working Register									xxxx xxxx	uuuu uuuu	*****	
2AH	BSRCN								BSR[0] 0000 0000	-----*		
2BH	STATUS				C	DC	N	OV	Z	...x xxxx	...u uuuu	-----*		
2CH	PSTATUS	PD	TO	IDLEB	BOR		SKERR			000d .0.	uduu .d.	rw0,rw0,rw0,rw0,-,rw0,-,-		
2DH	LVDCN1	ENLVD	LVD	VJ1	VJ2	VLDX[3:0]								
2EH	LVDCN2	VSL	SVIN[2:0]			SVIP[3:0]								
2FH	SBMSET1	SKRST	HAOTR[5:0]									x.xx xxxx	u.uu uuuu	*****
30H	MCKCN1	CPUCK[1:0]		HSS[1:0]		HSCK	ENHAO			0000 0001	0000 0001	*****		
31H	MCKCN2	LCDS[2:0]		ADCCK	PERCK	BZS[2:0]				0000 0000	0000 0000	*****		
32H	TMACN	ENTMA	TMACK	TMAS[1:0]		ENWDT	WDTS[2:0]			0000 0000	0000 0000	***** w1,***		
33H	TMAR	TimerA data register									xxxx xxxx	uuuu uuuu	r,r,f,r r,r,f,r	
34H	TMCCN	ENTMC	TMCCK[1:0]	TMCS1[2:0]		TMCS0[1:0]				0000 0000	0000 0000	*****		
35H	PRC	TimerC programmable register									1111 1111	1111 1111	*****	
36H	TMCR	TimerC register									0000 0000	0000 0000	r,r,f,r r,r,f,r	
37H	PWMCN	ENPWM	PWMRL[1:0]							0000 0000	0000 0000	*****		
38H	PWMR	PWM MSB Byte register									xxxx xxxx	uuuu uuuu	*****	
39H	LCDCN1	ENLCD	LC DPR	VLC DX[1:0]		LCDBF	LCDBI[1:0]			0000 000.	0000 000.	*****,-		
3AH	LCDCN2	LCDBL	LC DMX[1:0]							000.	000.	*****,-		
3BH	LCD0	Segment SEG1@[7:4] and SEG0@[3:0] data register of LCD									xxxx xxxx	uuuu uuuu	*****	
3CH	LCD1	Segment SEG3@[7:4] and SEG2@[3:0] data register of LCD									xxxx xxxx	uuuu uuuu	*****	
3DH	LCD2	Segment SEG5@[7:4] and SEG4@[3:0] data register of LCD									xxxx xxxx	uuuu uuuu	*****	
3EH	LCD3	Segment SEG7@[7:4] and SEG6@[3:0] data register of LCD									xxxx xxxx	uuuu uuuu	*****	
3FH	LCD4	Segment SEG9@[7:4] and SEG8@[3:0] data register of LCD									xxxx xxxx	uuuu uuuu	*****	
40H	LCD5	Segment SEG11@[7:4] and SEG10@[3:0] data register of LCD									xxxx xxxx	uuuu uuuu	*****	
41H	LCD6	Segment SEG13@[7:4] and SEG12@[3:0] data register of LCD									xxxx xxxx	uuuu uuuu	*****	
42H	LCD7	Segment SEG14@[3:0] data register of LCD								 xxxx uuuu	-----*	
46H										0000 0.0	0000 0.0	*****,-		
47H										.000 0110	.000 0110	-,r,r,f,r r,r,f,rw0		
48H									 0000 0000	*****		
49H										...x xxxx	...u uuuu	-----*		
4AH										xxxx xxxx	uuuu uuuu	*****		
4BH										xxxx xxxx	uuuu uuuu	*****		
4CH										xxxx xxxx	uuuu uuuu	r,r,f,r r,r,f,r		

“-”no use, “*”read/write, “w”write, “r”read, “r0”only read 0, “r1”only read 1, “w0”only write 0, “w1”only write 1
 “. ”unimplemented bit, “x”unknown, “u”unchanged, “d”depends on condition

Address	File Name	Bit7	Bit6	Bit5	Bit4	Bit3	Bit2	Bit1	Bit0	A-RESET	i-RESET	R/W	
4DH	PT1	PT1.7				PT1.3		PT1.1	PT1.0	xxxx xxxx	uuuu uuuu	r,r,r,r	
4EH	TRISC1	TC1.7				TC1.3		TC1.1	TC1.0	0000 0000	0000 0000	r,r,r,r	
4FH	PT1PU	PU1.7				PU1.3		PU1.1	PU1.0	0000 0000	0000 0000	r,r,r,r	
50H	PT1M1	PM1.7				INTEG1[1:0]		INTEG0[1:0]		0000 0000	0000 0000	r,r,r,r	
51H	PT2	PT2.7	PT2.6	PT2.5	PT2.4	PT2.3	PT2.2	PT2.1	PT2.0	xxxx xxxx	uuuu uuuu	r,r,r,r	
52H	TRISC2	TC2.7	TC2.6	TC2.5	TC2.4	TC2.3	TC2.2	TC2.1	TC2.0	0000 0000	0000 0000	r,r,r,r	
53H	PT2DA	DA2.7	DA2.6	DA2.5	DA2.4	DA2.3			PM2.2[1:0]	0000 0.00	0000 0.00	r,r,r,r	
54H	PT2PU	PU2.7	PU2.6	PU2.5	PU2.4	PU2.3	PU2.2	PU2.1	PU2.0	0000 0000	0000 0000	r,r,r,r	
55H										xxx. 000.	uuu. 000.	r,r,r,r	
56H										000. 0.0.	000. 0.0.	r,r,r,r	
57H	PAX6												
58H	PA54	PS5	DS5	FS5	SS5	PS4	DS4	FS4	SS4				
59H	PA32	PS3	DS3	FS3	SS3	PS2	DS2	FS2	SS2				
5AH	PA10	PS1	DS1	FS1	SS1	PS0	DS0	FS0	SS0				
5BH	PWRCN	DMMBIAS	SAGND[1:0]	ENVS	ENREFO	ENLDO			LDOC[1:0]=11				
5CH	PWRCN2	MCUBIAS		ENCOMP		RSTCOMB	RSLPF	RSRMS					
5DH	ADCN1	SDIO	SREFO	SFT1<1:0>		SFUVR<3:0>							
5EH	ADCN2			SMODE<7:0>									
5FH	ADCN3			SCMPRH<3:0>		SCMPRL<3:0>							
60H	ADCN4			SCMPI<2:0>	AD1CHOP<1:0>	AD1OSR<2:0>							
61H	ADCN5			SAD1FP<3:0>	HSAD	SAD1FN<2:0>							
62H	ADCN6			SAD1RH<2:0>	SAD1RL<2:0>	SAD1I<1:0>							
63H	ADCN7	ENAD1	AD1IG<1:0>	AD1RG	AD1RHBUF	AD1RLBUF	AD1IPBUF	AD1INBUF					
64H	RMSCN	ENRMS	ENLPF	ENSQRE=1	LPFBW<1>=	LPFBW<0>							
65H													
66H													
67H													
68H													
69H													
6AH													
6BH													
6CH													
6DH													
6EH	CTSTA			CMPHO	CMPLO								
6FH													
70H													
71H													
72H													
73H													
74H													
75H	RMSDATA4	RMS<37:30>								xxxx xxxx	uuuu uuuu	r,r,r,r	
76H	RMSDATA3	RMS<29:22>								xxxx xxxx	uuuu uuuu	r,r,r,r	
77H	RMSDATA2	RMS<21:14>								xxxx xxxx	uuuu uuuu	r,r,r,r	
78H	RMSDATA1	RMS<13:6>								xxxx xxxx	uuuu uuuu	r,r,r,r	
79H	RMSDATA0	RMS<5:0>								xxxx xxxx	uuuu uuuu	r,r,r,r	
7AH	LPFDATAU	LPF<18:11>								xxxx xxxx	uuuu uuuu	r,r,r,r	
7BH	LPFDATAH	LPF<10:3>								xxxx xxxx	uuuu uuuu	r,r,r,r	
7CH	LPFDATAL	LPF<2:0>								xxxx xxxx	uuuu uuuu	r,r,r,r	
7DH	AD1DATAU	AD1<18:11>								xxxx xxxx	uuuu uuuu	r,r,r,r	
7EH	AD1DATAH	AD1<10:3>								xxxx xxxx	uuuu uuuu	r,r,r,r	
7FH	AD1DATAL	AD1<2:0>								xxxx xxxx	uuuu uuuu	r,r,r,r	
80H ~ FFH	GPR0	General Purpose Register as 128Byte									xxxx xxxx	uuuu uuuu	r,r,r,r
100H~17FH	GPR1	General Purpose Register as 128Byte									xxxx xxxx	uuuu uuuu	r,r,r,r

5. Absolute Maximum Ratings

Absolute maximum ratings over operating free-air temperature (unless otherwise noted)

Voltage applied at VDD (VDDA) to VSS (VSSA)	-0.2 V to 4.0 V
Voltage applied to any pin	-0.2 V to $V_{DD} + 0.3$ V
Diode current at any device terminal	± 2 mA
Storage temperature range, Tstg	-55°C to 150°C
Total power dissipation	0.5w
Lead temperature (soldering, 10s)	300°C

5.1 Recommended Operating Conditions

$T_A = -40^\circ\text{C} \sim 85^\circ\text{C}$, unless otherwise noted

Sym.	Parameter	Test Conditions	Min.	Typ.	Max.	unit
V_{DD}	Supply Voltage	All digital peripherals and CPU	2.2		3.6	V
		Analog peripherals	2.5		3.6	
V_{SS}	Supply Voltage		0		0	

5.2 Internal RC Oscillator

$T_A = 25^{\circ}\text{C}, V_{DD} = 3.0\text{V}$, unless otherwise noted

Sym.	Parameter	Test Conditions	Min.	Typ.	Max.	unit
HAO	High Speed Oscillator frequency	ENHAO[0]=1		4		MHz
LPO	Low Power Oscillator frequency	V_{DD} supply voltage be enable LPO		32		KHz

5.3 Supply Current into VDD Excluding Peripherals Current

$T_A = 25^{\circ}\text{C}, V_{DD} = 3.0\text{V}, \text{OSC_LPO} = 32\text{KHz}$, unless otherwise noted

Sym.	Parameter	Test Conditions	Min.	Typ.	Max.	unit
I_{AM1}	Active mode 1	OSC_HAO = 4MHz, CPU_CK = 4MHz		0.36	0.55	mA
I_{AM2}	Active mode 2	OSC_HAO = 4MHz, CPU_CK = 2MHz		0.2	0.3	mA
I_{LP3}	Low Power 3	OSC_HAO = off, CPU_CK = off, Sleep state		0.65	1.2	uA

OSC_HAO : Internal High Accuracy Oscillator frequency.

CPU_CK : CPU core work frequency.

5.4 Port 1~2

$T_A = 25^{\circ}\text{C}, V_{DD} = 3.0\text{V}$, unless otherwise noted

Sym.	Parameter	Test Conditions	Min.	Typ.	Max.	unit
Input voltage and Schmitt trigger and leakage current and timing						
V_{IH}	High-Level input voltage				2.1	V
V_{IL}	Low-Level input voltage		0.9			
V_{hys}	Input Voltage hysteresis($V_{IH} - V_{IL}$)			0.8		V
I_{LKG}	Leakage Current				0.1	uA
R_{PU}	Port pull high resistance			180		k Ω
Output voltage and current and frequency						
V_{OH}	High-level output voltage	$I_{OH}=10\text{mA}$	$V_{DD} - 0.3$			V
V_{OL}	Low-level output voltage	$I_{OL}=-10\text{mA}$		$V_{SS} + 0.3$		

5.5 Reset(Brownout, External RST pin, Low Voltage Detect)

T_A = 25°C, V_{DD} = 3.0V, unless otherwise noted

Sym.	Parameter	Test Conditions	Min.	Typ.	Max.	unit	
BOR	Pulse length needed to accepted reset internally, t _{d-LVR}		2			us	
	V _{DD} Start Voltage to accepted reset internally (L→H), V _{LVR}		1.6	1.85	2.1	V	
	Hysteresis, V _{HYS-LVR}		70			mV	
RST	Pulse length needed as RST/VPP pin to accepted reset internally, t _{d-RST}		2			us	
	Input Voltage to accepted reset internally		0.9			V	
	Hysteresis, V _{HYS-RST}		0.8			V	
LVD Compare Mode	Operation current, I _{LVD}		10			15	uA
	External input voltage to compare reference voltage		1.2				V
	Compare reference voltage temperature drift		T _A = -40°C ~ 85 °C		100		ppm/°C
	Detect V _{DD} voltage rang by user option, V _{SVS} VLDx[3:0]=1110b		3.3			V	
	Detect V _{DD} voltage rang by user option, V _{SVS} VLDx[3:0]=1101b		3.2				
	Detect V _{DD} voltage rang by user option, V _{SVS} VLDx[3:0]=1100b		3.1				
	Detect V _{DD} voltage rang by user option, V _{SVS} VLDx[3:0]=1011b		3.0				
	Detect V _{DD} voltage rang by user option, V _{SVS} VLDx[3:0]=1010b		2.9				
	Detect V _{DD} voltage rang by user option, V _{SVS} VLDx[3:0]=1001b		2.8				
	Detect V _{DD} voltage rang by user option, V _{SVS} VLDx[3:0]=1000b		2.7				
	Detect V _{DD} voltage rang by user option, V _{SVS} VLDx[3:0]=0111b		2.6				
	Detect V _{DD} voltage rang by user option, V _{SVS} VLDx[3:0]=0110b		2.5				
	Detect V _{DD} voltage rang by user option, V _{SVS} VLDx[3:0]=0101b		2.4				
	Detect V _{DD} voltage rang by user option, V _{SVS} VLDx[3:0]=0100b		2.3				
	Detect V _{DD} voltage rang by user option, V _{SVS} VLDx[3:0]=0011b		2.2				
	Detect V _{DD} voltage rang by user option, V _{SVS} VLDx[3:0]=0010b		2.1				
	Detect V _{DD} voltage rang by user option, V _{SVS} VLDx[3:0]=0001b		2.0				
	VDD Ratio	Comparator Offset Error		-150	150		mV
Compare Mode	VDD Ratio Error		-5	5			%
BOR : Brownout Reset LVR : Low Voltage Reset of BOR LVD : Low Voltage Detect RST : External Reset pin							

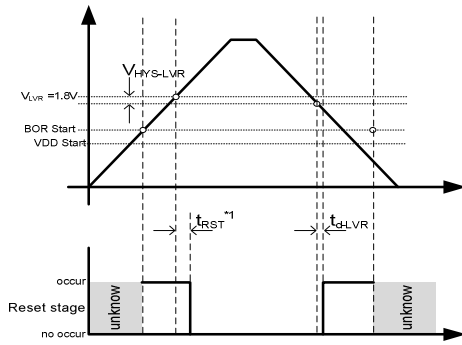

Figure 6.5-1 BOR reset diagram

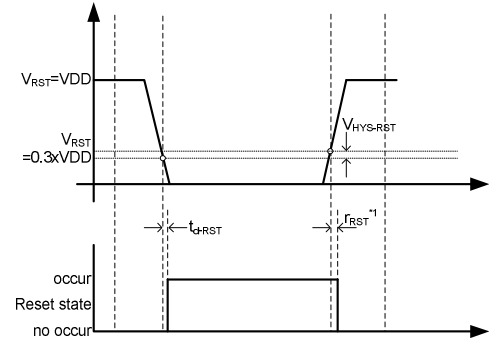

Figure 6.5-2 RST reset diagram

*1 t_{RST} : Please see BOR Introduce of HY12Pxx series User's Guide (UG-HY12S65-Vxx).

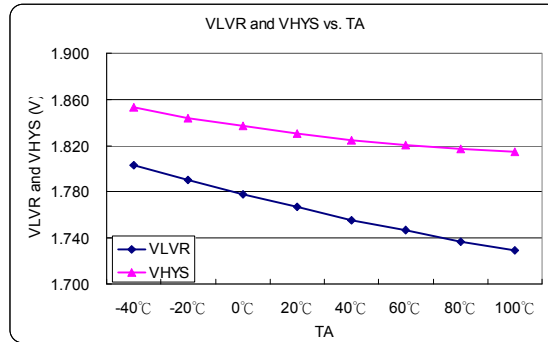

Figure 6.5-3 VLVR and VHYS vs. Temperature

5.6 Power System

$T_A = 25^\circ\text{C}, V_{DD} = 3.0\text{V}$, unless otherwise noted

Sym.	Parameter	Test Conditions		Min.	Typ.	Max.	unit
VDDA	VDDA operation current, I_{VDDA}	$I_L = 0\text{mA}$	LDOC[1:0]=00b	22			μA
	Select VDDA output voltage	$I_L = 0.1\text{mA}$, $V_{DD}=3\text{V}$	LDOC[1:0]=00b	3.6			V
	Load Regulation	$V_{DD}=2.4\text{V}$ $I_L = 1\sim 5\text{mA}$	LDOC[1:0]=00b	10			mV
	Line Regulation	$V_{DD}=2.4\text{V}\sim 3.6\text{V}$ $I_L = 1\text{mA}$	LDOC[1:0]=00b	40			mV
	Temperature drift	LDOC[1:0]=11b	$T_A=-40^\circ\text{C}\sim 85^\circ\text{C}$	100			ppm/ $^\circ\text{C}$
	V_{DD} Voltage drift	$I_L = 0.1\text{mA}$	$V_{DD}=2.5\text{V}\sim 3.6\text{V}$	± 0.2			%/V
AGND	AGND operation current, I_{Agnd}	SAGND#00b	$I_L = 0\text{mA}$	20			μA
	Output voltage, V_{Agnd}		$I_L = 0\mu\text{A}$	1.0			V
	Output voltage with Load		$I_L = \pm 200\mu\text{A}$	0.98	1.02		V_{AGND}
REFO	V(REFO,AGND)	ENLDO=1b,	$I_L = 0\mu\text{A}$	1.2			V
	Temperature drift	SAGND#00b	$T_A=-40^\circ\text{C}\sim 85^\circ\text{C}$	100			ppm/ $^\circ\text{C}$
	RMS Noise			60			μVrms

5.7 LCD

$T_A = 25^\circ\text{C}, V_{DD} = 3.0\text{V}, C_{VLCD} = 4.7\mu\text{F}$, unless otherwise noted.

Sym.	Parameter	Test Conditions		Min.	Typ.	Max.	unit
I_{LCD}	Operation supply current without output buffer.(all segment turn on)	LCDPR[0]=1	$V_{DD} = 2.2\text{V}$	20			μA
			$V_{DD} = 3.0\text{V}$				
VLCD	Supply Voltage at VLCD pin	LCDPR[0]=0		2.2	3.6		V
	Embedded Charge Pump output voltage at VLCD pin	LCDPR[0]=1, $C_{VLCD} = 4.7\mu\text{F}$	VLCDX[1:0]=11b	2.295	2.55	2.805	V
			VLCDX[1:0]=10b	2.52	2.8	3.08	
			VLCDX[1:0]=01b	2.745	3.05	3.355	
			VLCDX[1:0]=00b	2.97	3.3	3.63	
Z_{LCD}	Output impedance with LCD buffer	$f_{LCD} = 128\text{Hz}, VLCD=3.05\text{V}$		10			k Ω

5.8 $\Sigma\Delta$ ADC, Power Supply and Recommended Operating Conditions

$T_A = 25^\circ\text{C}$, $V_{DD} = 3.0\text{V}$, $V_{DDA}=3.6\text{V}$, $V_R=1.2\text{V}$, $AGND=0.5V_{DD}$, ADC Clock=400kHz Input buffer on unless otherwise noted

Sym.	Parameter	Test Conditions		Min.	Typ.	Max.	unit
$f_{\Sigma\Delta\text{ADC}}$	Modulator sample frequency, ADC_CK			400			KHz
$I_{\Sigma\Delta\text{ADC}}$	Operation supply current	Input gain =0.9, input buffer on ADC_CK=400KHz		550			μA
$D_{\Sigma\Delta\text{ADC}}$	Maximum ADC Output Code (ADC Gain Factor)	OSR=2500~20000		17D79		d	
		OSR=64~256		3FFFF			
		OSR=32		3FD7C			
Eos	Input offset voltage	Chopper on OSR=20000	Input gain=0.9, reference gain=1	20	100	μV	
			Input gain=3.6, reference gain=0.33	5	10		
Rev	Roll-over error voltage	Chopper on OSR=20000	Input gain=0.9, reference gain=1	200	600	μV	
			Input gain=3.6, reference gain=0.33	10	30		
Vrms	Input RMS Noise	Chopper on, OSR=20000, input gain=0.9 reference gain=1		10		μV	
		Chopper on, OSR=20000, input gain=3.6 reference gain=0.33		2			
		Chopper off, OSR=32, input gain=0.9 reference gain=1		400			
		Chopper off, OSR=32, input gain=3.6 reference gain=0.33		80			
NM	Normal Rejection ratio	Chopper On OSR=20000 ADCLK=1	Input gain=0.9, reference gain=1. Vin=200mVrms 50/60Hz	60		dB	
			Input gain=3.6, reference gain=0.33. Vin=20mVrms 50/60Hz				
AC_{BW}	AC Measurement	OSR=32, LPFBW=1024	0.5% error	20	1500	Hz	
	Bandwidth		3dB	6000			

5.9 ΣΔADC, Temperature Sensor

$T_A = 25^\circ\text{C}, V_{DD} = 3.0\text{V}, V_{DDA}=2.4\text{V}$, unless otherwise noted

Sym.	Parameter	Test Conditions	Min.	Typ.	Max.	unit
TC_S	Sensor temperature drift			178		$\mu\text{V}/^\circ\text{C}$
KT	Absolute Temperature Scale 0°K	ADC Gain=0.9, OSR=20000, Input buffer Off, VR:REFO-AGND		-281		$^\circ\text{C}$
TC_{ERR}	One point calibrate error temperature	Calibration at 25°C of $-40^\circ\text{C} \sim 85^\circ\text{C}$		± 2		$^\circ\text{C}$

5.10 Analog Input and Switch Performance

$T_A = 25^\circ\text{C}, V_{DD} = 3.0\text{V}, V_{DDA}=3.6\text{V}$ AGND=0.5VDDA unless otherwise noted

Sym.	Parameter	Test Conditions	Min.	Typ.	Max.	unit
I_{AL}	Analog Input Leakage Current	AGND=0.5 VDDA		10	100	pA
		AGND=0.3VDDA		10	100	
		AGND=0.1VDDA		100	500	
Rsw	Switch Turn On Resistance	PS0,PS1		20		Ohm
		DS0,DS1		40		
		DS2~DS5, PS2~PS5		80		
		SS0~SS5,FS0~FS5		400		

5.11 DMM Comparator

$T_A = 25^\circ\text{C}, V_{DD} = 3.0\text{V}, V_{DDA}=3.6\text{V}$ AGND=0.5VDDA, unless otherwise noted

Sym.	Parameter	Test Conditions	Min.	Typ.	Max.	unit
I_{CMP}	Comparator Supply Current					μA
V_I	Comparator Input Range	CMPL	0		$V_{DDA}-0.7$	V
		CMPH	0.4		V_{DDA}	
Vos	Comparator Input Offset Voltage	CMPL , VRLCMP=AGND		5		mV
		CMPH VRHCMP=AGND		5		
V_n	Comparator Input peak to peak noise	CMPL		5		mV
		CMPH		5		
		CMPH&CMPL		10		
CMP_{BW}	Comparator Bandwidth	VRHCMP=AGNDP<2>, VRLCMP=AGNDN<2> VIN=100mVrms		1		MHz

6. Ordering Information

Device No. ¹	Package Type	Pins	Package Drawing		Code ²	Shipment Packing Type	Unit Q'ty	Material Composition	MSL ³
HY12P63-D000	Die	-	D	000	000	-	100	Green ⁴	-
HY12P63-L064	LQFP	64	L	064	000	Tray	250	Green ⁴	MSL-3

¹ **Device No.: Model No. – Package Type Description – Code** (Blank Code/ Standard/ Customized Programming Code)

Ex: Your customized programming code is 008 and you require die shipment.

The device No. will be HY12P63-D000-008.

Ex: You request blank code in die package.

The device No. will be HY12P63-D000.

Ex: You request blank code in LQFP 64 package.

The device No. will be HY12P63-L064.

And please clearly indicate the shipment packing type when placing orders.

Ex: Your customized programming code is 008 and you require products in LQFP 64 package.

The device No. will be HY12P63-L064-008.

And please clearly indicate the shipment packing type when placing orders.

² **Code :**

“001”~ “999” is standard or customized programming code.

Blank code does not have these numbers.

³ **MSL:**

The Moisture Sensitivity Level ranking conforms to IPC/JEDEC J-STD-020 industry standard categorization.

The products are processed, packed, transported and used with reference to IPC/JEDEC J-STD-033.

⁴ **Green (RoHS & no Cl/Br):**

HYCON products are Green products that compliant with RoHS directive and are Halogen free (Br/Cl<0.1%)

7. Packaging Information

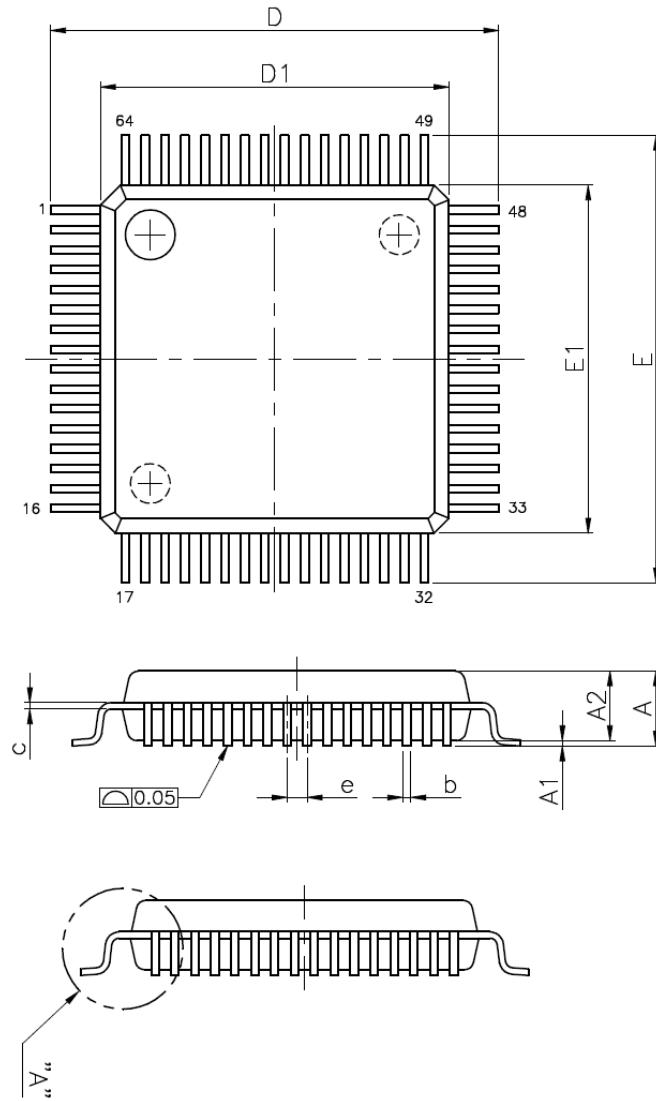

VARIATIONS (ALL DIMENSIONS SHOWN IN MM)

SYMBOLS	MIN.	NOM.	MAX.
A	—	—	1.60
A1	0.05	—	0.15
A2	1.35	1.40	1.45
b	0.13	0.18	0.23
c	0.09	—	0.20
D	9.00 BSC		
D1	7.00 BSC		
e	0.40 BSC		
E	9.00 BSC		
E1	7.00 BSC		
L	0.45	0.60	0.75
L1	1.00 REF		
θ	0°	3.5°	7°

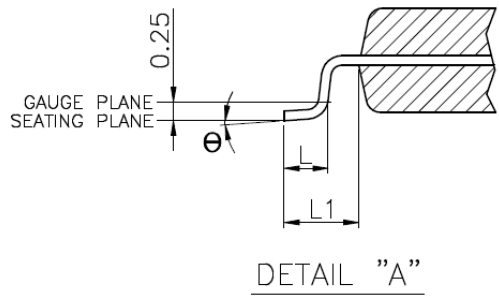

JEDEC MS-026 Compliant

8. Revision Record

Major differences are stated thereafter:

Version	Page	Revision Summary
V01	All	First edition