



HY16F19X Peripheral Driver C Library

Table of Contents

1. Overview	15
1.1 Introduction	15
1.2 Relative Document	15
2. SYS Driver	16
2.1 Introduction	16
2.2 Functions	16
2.2.1 SYS_SleepFlagRead	16
2.2.2 SYS_SleepFlagClear	17
2.2.3 SYS_WdogFlagRead	17
2.2.4 SYS_WdogFlagClear	17
2.2.5 SYS_ResetFlagRead	18
2.2.6 SYS_ResetFlagClear	18
2.2.7 SYS_BORFlagRead	19
2.2.8 SYS_BORFlagClear	19
2.2.9 SYS_EnableGIE	20
2.2.10 SYS_DisableGIE	20
2.2.11 SYS_LowPower	21
2.2.12 SYS_INTPriority	21
3. CLOCK Driver	23
3.1 Introduction	23
3.2 The block diagram of CLOCK	24
3.3 Type Definition	24
E_CLOCK_SOURCE	25
3.4 Functions	25
3.4.1 DrvCLOCK_EnableHighOSC	25
3.4.2 DrvCLOCK_CloseEHOSC	26
3.4.3 DrvCLOCK_CLOSEIHOSC	26
3.4.4 DrvCLOCK_SELECTIHOSC	27
3.4.5 DrvCLOCK_ENABLELOWOSC	27
3.4.6 DrvCLOCK_CLOSEELOSC	28
3.4.7 DrvCLOCK_SelectMCUClock	28
3.4.8 DrvCLOCK_TRIMHAO	29
3.4.9 DrvCLOCK_CalibrateHAO	30
4. TIMER/WDT Driver	31
4.1 Introduction	31
4.2 The functional block diagram	32

4.2.1 The block diagram of WDT	32
4.2.2 The block diagram of Timer A	32
4.2.3 The block diagram of Timer B	33
4.2.4 The block diagram of Timer C	33
4.2.4 The block diagram of Timer B2	34
4.3 Type Definition	36
E_WDT_PRE_SCALER	36
E_TIMER_CHANNEL	36
E_TMB_MODE	36
E_TRIGGER_SOURCE	36
E_DRVTIMER_CLOCK_SOURCE	37
E_CAPTURE_SOURCE	37
4.4 Functions	37
4.4.1 DrvWDT_Open	37
4.4.2 DrvWDT_COUNTERREAD	38
4.4.3 DrvWDT_CLEARWDT	38
4.4.4 DrvTMA_Open	39
4.4.5 DrvTMA_Close	40
4.4.6 DrvTMA_COUNTERREAD	40
4.4.7 DrvTMA_CLEARTMA	41
4.4.8 DrvTIMER_EnableInt	41
4.4.9 DrvTIMER_DisableInt	42
4.4.10 DrvTIMER_GetIntFlag	42
4.4.11 DrvTIMER_ClearIntFlag	43
4.4.12 DrvTMB_Open	43
4.4.13 DrvTMBC_CLK_SOURCE	44
4.4.14 DrvTMBC_CLK_DISABLE	45
4.4.15 DrvTMA_CLEARTMB	46
4.4.16 DrvTMB_COUNTER_READ	46
4.4.17 DrvTMB_Close	46
4.4.18 DrvPWM0_Open	47
4.4.19 DrvPWM1_Open	48
4.4.20 DrvPWM1_COUNT_CONDITION	49
4.4.21 DrvPWM0_Close	49
4.4.22 DrvPWM1_Close	50
4.4.23 DrvCAPTURE1_Open	50
4.4.24 DrvCAPTURE2_Open	52
4.4.25 DrvCAPTURE1_READ	52
4.4.26 DrvCAPTURE2_READ	53

4.4.27	DrvCAPTURE_INPUT_PORT	53
4.4.28	DrvTMB_TCI1Edge	54
4.4.29	DrvTMB_CPI1Input.....	54
4.4.30	DrvTMB2_Open.....	55
4.4.31	DrvTMB2_Close	56
4.4.32	DrvTMB2_CLK_SOURCE	57
4.4.33	DrvTMB2_CLK_DISABLE	57
4.4.34	DrvTMB2_CLEAR_TMB	58
4.4.35	DrvTMB2_COUNTER_READ.....	58
4.4.36	DrvPWM2_Open.....	59
4.4.37	DrvPWM3_Open.....	60
4.4.38	DrvTMB2PWM_COUNT_CONDITION.....	60
4.4.39	DrvPWM2_Close	61
4.4.40	DrvPWM3_Close	61
4.4.41	DrvTMB2_CPI3Input.....	62
4.4.42	DrvTMB2_TCI3Edge	63
5.	GPIO Driver.....	64
5.1	Introduction	64
5.2	The block diagram of GPIO.....	66
5.3	Type Definition	66
	E_DRVGPIO_PORT	66
	E_DRVGPIO_IO	66
	E_DRVGPIO_IntTriMethod.....	66
	E_DRVGPIO_CLOCK_SOURCE	67
5.4	Functions.....	67
5.4.1	DrvGPIO_Open	67
5.4.2	DrvGPIO_SetBit.....	68
5.4.3	DrvGPIO_ClrBit	68
5.4.4	DrvGPIO_GetBit	69
5.4.5	DrvGPIO_SetPortBits	70
5.4.6	DrvGPIO_ClrPortBits.....	70
5.4.7	DrvGPIO_GetPortBits.....	71
5.4.8	DrvGPIO_IntTrigger.....	71
5.4.9	DrvGPIO_CLK_GENERATOR.....	72
5.4.10	DrvGPIO_CLEAR_INT_FLAG	73
5.4.11	DrvGPIO_GET_IntFlag	73
5.4.12	DrvGPIO_Close	74
5.4.13	DrvGPIO_LCDIOOpen	75
5.4.14	DrvGPIO_LCDIOClose.....	75

5.4.15	DrvGPIO_ LCDSetPorts	76
5.4.16	DrvGPIO_ LCDClrPorts	77
5.4.17	DrvGPIO_ LCDSetBit	78
5.4.18	DrvGPIO_ LCDClrBit	78
5.4.19	DrvGPIO_ LCDIOGetPorts	79
5.4.20	DrvGPIO_ LCDIOGetBit	80
5.4.21	DrvGPIO_ EnableAnalogPin	80
5.4.22	DrvGPIO_PT1_ EnableINPUT	81
5.4.23	DrvGPIO_PT1_ DisableINPUT	82
5.4.24	DrvGPIO_PT1_ EnablePullHigh	82
5.4.25	DrvGPIO_PT1_ DisablePullHigh	83
5.4.26	DrvGPIO_PT1_ EnableOUTPUT	83
5.4.27	DrvGPIO_PT1_ DisableOUTPUT	84
5.4.28	DrvGPIO_PT1_ EnableINT	84
5.4.29	DrvGPIO_PT1_ DisableINT	85
5.4.30	DrvGPIO_PT1_ IntTriggerPorts	85
5.4.31	DrvGPIO_PT1_ IntTriggerBit	86
5.4.32	DrvGPIO_PT1_ GetIntFlag	87
5.4.33	DrvGPIO_PT1_ ClearIntFlag	87
5.4.34	DrvGPIO_PT1_ GetPortBits	88
5.4.35	DrvGPIO_PT1_ SetPortBits	88
5.4.36	DrvGPIO_PT1_ ClrPortBits	88
5.4.37	DrvGPIO_PT2_ EnableINPUT	89
5.4.38	DrvGPIO_PT2_ DisableINPUT	90
5.4.39	DrvGPIO_PT2_ EnablePullHigh	90
5.4.40	DrvGPIO_PT2_ DisablePullHigh	91
5.4.41	DrvGPIO_PT2_ EnableOUTPUT	91
5.4.42	DrvGPIO_PT2_ DisableOUTPUT	92
5.4.43	DrvGPIO_PT2_ EnableINT	92
5.4.44	DrvGPIO_PT2_ DisableINT	92
5.4.45	DrvGPIO_PT2_ IntTriggerPorts	93
5.4.46	DrvGPIO_PT2_ IntTriggerBit	94
5.4.47	DrvGPIO_PT2_ GetIntFlag	94
5.4.48	DrvGPIO_PT2_ ClearIntFlag	95
5.4.49	DrvGPIO_PT2_ GetPortBits	95
5.4.50	DrvGPIO_PT2_ SetPortBits	96
5.4.51	DrvGPIO_PT2_ ClrPortBits	96
5.4.52	DrvGPIO_PT3_ EnableINPUT	97
5.4.53	DrvGPIO_PT3_ DisableINPUT	97

5.4.54	DrvGPIO_PT3_EnablePullHigh	98
5.4.55	DrvGPIO_PT3_DisablePullHigh	98
5.4.56	DrvGPIO_PT3_EnableOUTPUT	99
5.4.57	DrvGPIO_PT3_DisableOUTPUT.....	99
5.4.58	DrvGPIO_PT3_GetPortBits	100
5.4.59	DrvGPIO_PT3_SetPortBits.....	100
5.4.60	DrvGPIO_PT3_ClrPortBits	101
5.4.61	DrvGPIO_PT6_EnableINPUT	101
5.4.62	DrvGPIO_PT6_DisableINPUT.....	102
5.4.63	DrvGPIO_PT6_EnableOUTPUT	102
5.4.64	DrvGPIO_PT6_DisableOUTPUT.....	103
5.4.65	DrvGPIO_PT6_GetPortBits	103
5.4.66	DrvGPIO_PT6_SetPortBits.....	104
5.4.67	DrvGPIO_PT6_ClrPortBits	104
5.4.68	DrvGPIO_PT7_EnableINPUT	105
5.4.69	DrvGPIO_PT7_DisableINPUT.....	105
5.4.70	DrvGPIO_PT7_EnableOUTPUT	106
5.4.71	DrvGPIO_PT7_DisableOUTPUT.....	106
5.4.72	DrvGPIO_PT7_GetPortBits	107
5.4.73	DrvGPIO_PT7_SetPortBits.....	107
5.4.74	DrvGPIO_PT7_ClrPortBits	108
5.4.75	DrvGPIO_PT8_EnableINPUT	108
5.4.76	DrvGPIO_PT8_DisableINPUT.....	109
5.4.77	DrvGPIO_PT8_EnableOUTPUT	109
5.4.78	DrvGPIO_PT8_DisableOUTPUT.....	110
5.4.79	DrvGPIO_PT8_GetPortBits	110
5.4.80	DrvGPIO_PT8_SetPortBits.....	110
5.4.81	DrvGPIO_PT8_ClrPortBits	111
5.4.82	DrvGPIO_PT9_EnableINPUT	111
5.4.83	DrvGPIO_PT9_DisableINPUT.....	112
5.4.84	DrvGPIO_PT9_EnableOUTPUT	112
5.4.85	DrvGPIO_PT9_DisableOUTPUT.....	113
5.4.86	DrvGPIO_PT9_GetPortBits	113
5.4.87	DrvGPIO_PT9_SetPortBits.....	114
5.4.88	DrvGPIO_PT9_ClrPortBits	114
5.4.89	DrvGPIO_PT10_EnableINPUT	115
5.4.90	DrvGPIO_PT10_DisableINPUT.....	115
5.4.91	DrvGPIO_PT10_EnableOUTPUT	116
5.4.92	DrvGPIO_PT10_DisableOUTPUT.....	116

5.4.93	DrvGPIO_PT10_GetPortBits	117
5.4.94	DrvGPIO_PT10_SetPortBits.....	117
5.4.95	DrvGPIO_PT10_ClrPortBits	118
5.4.96	DrvGPIO_PortIDIF.....	119
6.	ADC Driver	120
6.1	Introduction	120
6.2	The block diagram of ADC	121
6.3	Type Definition	122
	E_ADC_INPUT_CHANNEL.....	122
	E_ADC_REFV	122
	E_ADC_PGA & E_ADC_ADGN.....	122
	E_ADC_SIGNAL_SHORT	122
	E_ADC_VRPS_REF_VOLTAGE	122
	E_ADC_VRNS_REF_VOLTAGE	122
6.4	Functions.....	123
6.4.1	DrvADC_POSITIVE_INPUT_CHANNEL.....	123
6.4.2	DrvADC_NEGATIVE_INPUT_CHANNEL	123
6.4.3	DrvADC_INPUT_CHANNEL	124
6.4.4	DrvADC_INPUT_SWITCH.....	125
6.4.5	DrvADC_REF_INPUT_SHORT_CONTROL	126
6.4.6	DrvADC_PGA	126
6.4.7	DrvADC_AD_GAIN.....	127
6.4.8	DrvADC_GAIN.....	127
6.4.9	DrvADC_SetADC_DC_OFFSET	128
6.4.10	DrvADC_SetADC_REFERENCE_VOLTAGE.....	129
6.4.11	DrvADC_SetADC_FULL_REF_RANGE.....	130
6.4.12	DrvADC_SetADC_OSR.....	130
6.4.13	DrvADC_CLOCK_ENABLE	131
6.4.14	DrvADC_CLOCK_DISABLE	132
6.4.15	DrvADC_FAST_CHOPPER.....	132
6.4.16	DrvADC_COMB_FILTER.....	133
6.4.17	DrvADC_ENABLE_INT.....	133
6.4.18	DrvADC_DISABLE_INT.....	134
6.4.19	DrvADC_READ_INT_FLAG	134
6.4.20	DrvADC_CLEAR_INT_FLAG	134
6.4.21	DrvADC_ENABLE	135
6.4.22	DrvADC_DISABLE	135
6.4.23	DrvADC_GetConversionData.....	136
7.	SPI32 Driver.....	137

7.1 Introduction	137
7.2 The block diagram of SPI.....	138
7.3 Type Definition	138
E_DRVSPI_MODE	138
E_DRVSPI_TRANS_TYPE	138
E_DRVSPI_ENDIAN	138
E_DRVSPI_CS	139
7.4 Functions.....	139
7.4.1 DrvSPI32_Open.....	139
7.4.2 DrvSPI32_Close	140
7.4.3 DrvSPI32_IsBusy.....	141
7.4.4 DrvSPI32_SetClockFreq.....	141
7.4.5 DrvSPI32_IsRxBufferFull.....	142
7.4.6 DrvSPI32_IsTxBufferFull	143
7.4.7 DrvSPI32_EnableRxInt.....	143
7.4.8 DrvSPI32_EnableTxInt	144
7.4.9 DrvSPI32_DisableRxInt	144
7.4.10 DrvSPI32_DisableTxInt	145
7.4.11 DrvSPI32_GetRxIntFlag	145
7.4.12 DrvSPI32_GetTxIntFlag.....	146
7.4.13 DrvSPI32_ClrIntRxFlag	146
7.4.14 DrvSPI32_ClrIntTxFlag.....	147
7.4.15 DrvSPI32_Read.....	147
7.4.16 DrvSPI32_Write	148
7.4.17 DrvSPI32_Enable	148
7.4.18 DrvSPI32_BitLength	149
7.4.19 DrvSPI32_GetDCFlag	149
7.4.20 DrvSPI32_IsABFlag.....	150
7.4.21 DrvSPI32_IsOVFlag	150
7.4.22 DrvSPI32_IsRxFlag	151
7.4.23 DrvSPI32_SetEndian.....	151
7.4.24 DrvSPI32_SetCSO	152
7.4.25 DrvSPI32_DisableIO.....	152
7.4.26 DrvSPI32_EnableIO	153
8. UART Driver	154
8.1 Introduction	154
8.2 The block diagram of UART	156
8.3 Type Definition	157
E_DATABITS_SETTINGS	157

E_STOPBITS_SETTINGS.....	157
E_PARITY_SETTINGS.....	157
E_BAUD_RATE_SETTINGS.....	157
E_UART_ERROR_MESSAGE.....	157
8.4 Functions.....	158
8.4.1 DrvUART_Open.....	158
8.4.2 DrvUART_Close.....	159
8.4.3 DrvUART_EnableInt.....	160
8.4.4 DrvUART_GetTxFlag.....	160
8.4.5 DrvUART_GetRxFlag.....	161
8.4.6 DrvUART_ClrTxFlag.....	161
8.4.7 DrvUART_ClrRxFlag.....	162
8.4.8 DrvUART_Read.....	162
8.4.9 DrvUART_ClrABDOVF.....	162
8.4.10 DrvUART_Write.....	163
8.4.11 DrvUART_ENABLE_WAKEUP.....	163
8.4.12 DrvUART_GET_PERR.....	164
8.4.13 DrvUART_GET_FERR.....	164
8.4.14 DrvUART_GET_OERR.....	165
8.4.15 DrvUART_GETABDOVF.....	166
8.4.16 DrvUART_ENABLE_AUTO_BAUDRATE.....	166
8.4.17 DrvUART_DISABLE_AUTO_BAUDRATE.....	167
8.4.18 DrvUART_CheckTRMT.....	167
8.4.19 DrvUART_ClkEnable.....	167
8.4.20 DrvUART_ClkDisable.....	168
8.4.21 DrvUART_Enable.....	169
8.4.22 DrvUART_ConfigIO.....	169
8.4.23 DrvUART_TRStatus.....	170
8.4.24 DrvUART_IntType.....	170
8.4.25 DrvUART_DISABLE_WAKEUP.....	171
8.4.26 DrvUART_GET_NERR.....	171
8.4.27 DrvUART_ClrPERR.....	172
8.4.28 DrvUART_ClrFERR.....	172
8.4.29 DrvUART_ClrOERR.....	173
8.4.30 DrvUART_ClrNERR.....	173
8.4.31 DrvUART2_Open.....	174
8.4.32 DrvUART2_Enable.....	175
8.4.33 DrvUART2_Close.....	176
8.4.34 DrvUART2_EnableInt.....	176

8.4.35	DrvUART2_IntType	177
8.4.36	DrvUART2_GetTxFlag.....	177
8.4.37	DrvUART2_GetRxFlag	178
8.4.38	DrvUART2_ClrTxFlag.....	178
8.4.39	DrvUART2_ClrRxFlag	179
8.4.40	DrvUART2_Read.....	179
8.4.41	DrvUART2_Write.....	180
8.4.42	DrvUART2_ENABLE_WAKEUP	180
8.4.43	DrvUART2_DISABLE_WAKEUP	180
8.4.44	DrvUART2_ENABLE_AUTO_BAUDRATE	181
8.4.45	DrvUART2_DISABLE_AUTO_BAUDRATE	181
8.4.46	DrvUART2_GET_PERR.....	182
8.4.47	DrvUART2_GET_FERR	182
8.4.48	DrvUART2_GET_OERR.....	183
8.4.49	DrvUART2_GET_NERR.....	183
8.4.50	DrvUART2_ClrPERR.....	184
8.4.51	DrvUART2_ClrFERR	184
8.4.52	DrvUART2_ClrOERR	185
8.4.53	DrvUART2_ClrNERR.....	185
8.4.54	DrvUART2_GETABDOVF	185
8.4.55	DrvUART2_ClrABDOVF	186
8.4.56	DrvUART2_TRStatus	186
8.4.57	DrvUART2_CheckTRMT	187
8.4.58	DrvUART2_ClkEnable	187
8.4.59	DrvUART2_ClkDisable	188
8.4.60	DrvUART2_ConfigIO	189
9.	CMP Driver.....	190
9.1	Introduction	190
9.2	The block diagram of CMP.....	191
9.3	Type Definition	191
	E_NON_OVERLAP_PIN	191
	E_CMP_PIN.....	191
	E_NON_OVERLAP_VREF	191
9.4	Functions.....	192
9.4.1	DrvCMP_OPEN	192
9.4.2	DrvCMP_CLOSE	193
9.4.3	DrvCMP_ENABLE	193
9.4.4	DrvCMP_POSITIVE_INPUT.....	194
9.4.5	DrvCMP_NEGATIVE_INPUT	194

9.4.6	DrvCMP_INPUT_SWITCH	195
9.4.7	DrvCMP_OUTPUT_FILTER	195
9.4.8	DrvCMP_OUTPUT_PIN_ENABLE	196
9.4.9	DrvCMP_OUTPUT_PIN_DISABLE	196
9.4.10	DrvCMP_OUTPUT_PIN_INVERSE	197
9.4.11	DrvCMP_ENABLE_INT	197
9.4.12	DrvCMP_DISABLE_INT	198
9.4.13	DrvCMP_READ_INT_FLAG	199
9.4.14	DrvCMP_CLEAR_INT_FLAG	199
9.4.15	DrvCMP_INPUT	200
9.4.16	DrvCMP_RLO_CTRL	200
9.4.17	DrvCMP_RLO_REFERENCE_VOLTAGE	201
9.4.18	DrvCMP_ENABLE_NON_OVERLAP	202
9.4.19	DrvCMP_DISABLE_NON_OVERLAP	203
9.4.20	DrvCMP_READ_Data	203
10.	OPAMP Driver	204
10.1	Introduction	204
10.2	The block diagram of OPAMP	204
10.3	Type Definition	205
	E_OUTPUT_PIN	205
	E_OPN_PPIN	205
10.4	Functions	206
10.4.1	DrvOP_OPEN	206
10.4.2	DrvOP_CLOSE	206
10.4.3	DrvOP_POSITIVE_INPUT	207
10.4.4	DrvOP_NEGATIVE_INPUT	208
10.4.5	DrvOP_OPO_OUTPUT_ENABLE	209
10.4.6	DrvOP_OPO_OUTPUT_DISABLE	209
10.4.7	DrvOP_OUTPUT_FILTER	210
10.4.8	DrvOP_OUTPUT_PIN_ENABLE	210
10.4.9	DrvOP_OUTPUT_PIN_DISABLE	211
10.4.10	DrvOP_OUTPUT_PIN_INVERSE	211
10.4.11	DrvOP_OUTPUT_WITH_CHPCK	212
10.4.12	DrvOP_ENABLE_INT	212
10.4.13	DrvOP_DISABLE_INT	213
10.4.14	DrvOP_READ_INT_FLAG	213
10.4.16	DrvOP_FEEDBACK	214
11.	PMU Driver	215
11.1	Introduction	215

11.2 The block diagram of PowerManage	215
11.3 Type Definition.....	216
E_VDDA_OUTPUT_VOLTAGE	216
E_VDDA_LDO_ENABLE_CONTROL	216
11.4 Functions.....	217
11.4.1 DrvPMU_VDDA_VOLTAGE	217
11.4.2 DrvPMU_VDDA_LDO_ENABLE_CONTROL.....	217
11.4.3 DrvPMU_BANDGAP_ENABLE.....	218
11.4.4 DrvPMU_BANDGAP_DISABLE.....	218
11.4.5 DrvPMU_CHARGE_PUMP_ENABLE	219
11.4.6 DrvPMU_CHARGE_PUMP_DISABLE	219
11.4.7 DrvPMU_REFO_ENABLE	220
11.4.8 DrvPMU_REFO_DISABLE	220
11.4.9 DrvPMU_ADC_ANALOG_GROUND.....	221
11.4.10 DrvPMU_LDO_LOW_POWER	221
12. 8-bit Resistance Ladder Driver	223
12.1 Introduction	223
12.2 The block diagram of 8-bit Resistance Ladders.....	223
12.3 Type Definition	224
E_DAC_INPUT	224
12.4 Functions.....	225
12.4.1 DrvDAC_OPEN	225
12.4.2 DrvDAC_CLOSE	225
12.4.3 DrvDAC_ENABLE	226
12.4.4 DrvDAC_DISABLE	226
12.4.5 DrvDAC_OUTPUT_ENABLE	227
12.4.6 DrvDAC_OUTPUT_DISABLE	227
12.4.7 DrvDAC_P_INPUT	228
12.4.8 DrvDAC_N_INPUT	228
12.4.9 DrvDAC_DAO_BIT	229
12.4.10 DrvDAC_SetoutputIO	229
13. RTC Driver	231
13.1 Introduction	231
13.2 The block diagram of RTC	231
13.3 Type Definition	232
E_DRVRTC_CLOCK_SOURCE.....	232
E_DRVRTC_TICK	232
E_DRVRTC_HOUR_FORMAT	232
E_DRVRTC_FLAG	232

13.4 Functions.....	233
13.4.1 DrvRTC_SetFrequencyCompensation	233
13.4.2 DrvRTC_WriteEnable	233
13.4.3 DrvRTC_WriteDisable	234
13.4.4 DrvRTC_ClockSource	234
13.4.5 DrvRTC_AlarmEnable	235
13.4.6 DrvRTC_AlarmDisable	235
13.4.7 DrvRTC_PeriodicTimeEnable	236
13.4.8 DrvRTC_PeriodicTimeDisable.....	236
13.4.9 DrvRTC_Enable.....	237
13.4.10 DrvRTC_Disable.....	237
13.4.11 DrvRTC_HourFormat.....	238
13.4.12 DrvRTC_ReadState.....	238
13.4.13 DrvRTC_ClearState.....	239
13.4.14 DrvRTC_EnableInt.....	239
13.4.15 DrvRTC_DisableInt.....	240
13.4.16 DrvRTC_ReadIntFlag	240
13.4.17 DrvRTC_ClearIntFlag	241
13.4.18 DrvRTC_Write	241
13.4.19 DrvRTC_Read	242
13.4.20 DrvRTC_ClkConfig	243
14. I2C Driver	244
14.1 Introduction	244
14.2 The block diagram of IIC	244
14.3 Type Definition	245
E_DRVI2C_Status	245
E_DRVI2C_TIMEOUT_LIMIT	245
E_DRVI2C_INTERRUPT.....	245
E_DRVI2C_SLAVE_BIT	245
14.4 Functions.....	246
14.4.1 DrvI2C_Open.....	246
14.4.2 DrvI2C_Close	246
14.4.3 DrvI2C_SlaveSet	247
14.4.4 DrvI2C_SetIOPin	248
14.4.5 DrvI2C_WriteData.....	248
14.4.6 DrvI2C_Write3ByteData	249
14.4.7 DrvI2C_ReadData	249
14.4.8 DrvI2C_Ctrl	250
14.4.9 DrvI2C_EnableInt	250

14.4.10 DrvI2C_DisableInt.....	251
14.4.11 DrvI2C_ReadIntFlag	251
14.4.12 DrvI2C_ClearIntFlag	252
14.4.13 DrvI2C_ClearEIRQ	252
14.4.14 DrvI2C_ClearIRQ.....	253
14.4.15 DrvI2C_GetStatusFlag.....	253
14.4.16 DrvI2C_TimeOutEnable	255
14.4.17 DrvI2C_TimeOutDisable.....	256
14.4.18 DrvI2C_STSP	256
14.4.19 DrvI2C_MGetACK	257
14.4.20 DrvI2C_DisableOPin.....	257
15.LCD Driver	259
15.1 Introduction	259
15.2 The block diagram of LCD	259
15.3 Type Definition	260
15.4 Functions.....	260
15.4.1 DrvLCD_EnableCLK.....	260
15.4.2 DrvLCD_DisplayMode	261
15.4.3 DrvLCD_VLCDMode	261
15.4.4 DrvLCD_LcdDuty.....	262
15.4.5 DrvLCD_LCDBuffer	263
15.4.6 DrvLCD_SwpCOMSEG	263
15.4.7 DrvLCD_IOMode	264
15.4.8 DrvLCD_WriteData	264
15.4.9 DrvLCD_VLCDTrim	265
16. FLASH Driver	266
16.1 Introduction	266
16.2 Functions.....	267
16.2.1 DrvFlash_Burn_Word	267
16.2.2 ROM_BurnPage	267
16.2.3 ReadWord.....	268
16.2.4 ReadPage.....	268
16.2.5 PageErase	269
16.2.6 SectorErase	269
16.3 The storage structure of Flash	271
17. Library	272
17.1 Library File	272
18. Revision History	272
19. C Library Change List.....	274

1. Overview

1.1 Introduction

This document describes the HYCON™ HY16F19X series driver reference manual. System-level software developers can use the HYCON™ HY16F19X series driver to do the fast application software development, instead of using the register level programming, which can reduce the total development time significantly.

In this document, a description, usage and an illustrated example code are provided for each driver application interface. The full driver samples and driver source codes can be found in the BSP (Board Support Package) DVD of the HYCON™ HY16F19X series.

1.2 Relative Document

User can find the following documents in our website for other relative information.

- (1)HYCON HY16F19X Series Data Sheet
- (2)HYCON HY16F19X Series User's Guide
- (3)HYCON HY16F19X Series Hardware TOOL User Manual
- (4)HYCON HY16F19X Series Software TOOL User Manual
- (5)HYCON HY16F19X Series BSP (Board Support Package) DVD

2. SYS Driver

2.1 Introduction

The following functions are included in System Manager Section.

Item	Functions	Description
01	SYS_SleepFlagRead	Read Sleep Flag
02	SYS_SleepFlagClear	Clear Sleep Flag
03	SYS_WdogFlagRead	Read watch dog flag
04	SYS_WdogFlagClear	Clear watch dog flag
05	SYS_ResetFlagRead	Read reset flag of data
06	SYS_ResetFlagClear	Clear reset flag
07	SYS_BORFlagRead	Read BOR flag of data
08	SYS_BORFlagClear	Clear BOR flag
09	SYS_EnableGIE	Enable GIE and set priority level of interrupt
10	SYS_DisableGIE	Disable GIE
11	SYS_LowPower	Set the low power mode
12	SYS_INTPriority	Set the interrupt priority level of interrupt vector

2.2 Functions

2.2.1 SYS_SleepFlagRead

- **Prototype**

unsigned int SYS_SleepFlagRead (void);

- **Description**

Read Sleep Flag of data from SYSFLG registers.

Read the value of register 0X40104[3].

- **Parameters**

None

- **Include**

Peripheral_lib/System.h

- **Return Value**

0 : Normal

1 : Chip has entered Sleep Mode

- **Example**

```
/* Read Sleep Flag of data from SYSFLG registers. */
```

```
unsigned char temp_flag; temp_flag=SYS_SleepFlagRead ( );
```

2.2.2 SYS_SleepFlagClear

- **Prototype**

void SYS_SleepFlagClear(void);

- **Description**

Clear Sleep Flag.

Clear the register 0x40104[3]

- **Parameters**

None

- **Include**

Peripheral_lib/System.h

- **Return Value**

None

- **Example**

```
/* Clear Sleep Flag. */
```

```
SYS_SleepFlagClear ( );
```

2.2.3 SYS_WdogFlagRead

- **Prototype**

unsigned int SYS_WdogFlagRead (void);

- **Description**

Read watch dog flag of data from SYSFLG registers.

Read the value of register 0x40104[2]

- **Parameters**

None

- **Include**

Peripheral_lib/System.h

- **Return Value**

0 : Normal

1 : Watch dog has triggered

- **Example**

```
/* Read watch dog flag of data from SYSFLG registers. */
```

```
unsigned char flag; flag=SYS_WdogFlagRead ( );
```

2.2.4 SYS_WdogFlagClear

- **Prototype**

void SYS_WdogFlagClear(void);

- **Description**

Clear watch dog flag

Clear the register 0x40104[2]

- **Parameters**

None

- **Include**

Peripheral_lib/System.h

- **Return Value**

None

- **Example**

```
/* Clear watch dog flag */  
SYS_WdogFlagClear( );
```

2.2.5 SYS_ResetFlagRead

- **Prototype**

unsigned int SYS_ResetFlagRead (void);

- **Description**

Read reset flag of data from SYSFLG registers.

Read the value of register 0x40104[1]

- **Parameters**

None

- **Include**

Peripheral_lib/System.h

- **Return Value**

0 : Normal

1 : The Reset Pin has reset

- **Example**

```
/* Read reset flag of data from SYSFLG registers. */  
unsigned char flag; flag=SYS_ResetFlagRead ( );
```

2.2.6 SYS_ResetFlagClear

- **Prototype**

void SYS_ResetFlagClear(void);

- **Description**

Clear reset flag

Clear the value of register 0x40104[1]

- **Parameters**

None

- **Include**

Peripheral_lib/System.h

- **Return Value**

None

- **Example**

```
/* Clear reset flag */  
SYS_ResetFlagClear ( );
```

2.2.7 SYS_BORFlagRead

- **Prototype**

unsigned int SYS_BOR_FlagRead (void);

- **Description**

Read BOR flag of data from SYSFLG registers.
Read the value of register 0x40104[0]

- **Parameters**

None

- **Include**

Peripheral_lib/System.h

- **Return Value**

0 : Normal
1 : BOR has triggered

- **Example**

```
/* Read BOR flag of data from SYSFLG registers. */  
unsigned char flag; flag=SYS_BOR_FlagRead ( );
```

2.2.8 SYS_BORFlagClear

- **Prototype**

void SYS_BOR_FlagClear(void);

- **Description**

Clear BOR flag
Clear the value of register 0x40104[0]

- **Parameters**

None

- **Include**

Peripheral_lib/System.h

- **Return Value**

None

- **Example**

```
/* Clear BOR flag */
```

```
SYS_BOR_FlagClear ( );
```

2.2.9 SYS_EnableGIE

- **Prototype**

```
unsigned int SYS_EnableGIE (unsigned int uPriority unsigned short invector);
```

- **Description**

. Enable GIE and the corresponding interrupt vector, set the priority level of interrupt. The high level of priority will be responded first. The priority of interrupt vector is set by SYS_INTPriority().

- **Parameters**

uPriority [in]

Specify which priority level of interrupt can be responded. It could be 0~4

The priority level of the corresponding interrupt can be specified by SYS_INTPriority().

0: No interrupts are allowed

1: Only allows interrupts with the highest priority level.

2: Only allows interrupts with the highest and second highest priority level.

3: Only allows interrupts with the highest,second highest and lower priority level.

4: Only allows interrupts with the highest,second highest,lower and lowest priority level

invector[in] Select the interrupt vector[HW8:HW7:HW6:HW5:HW4:HW3:HW2:HW1:HW0]; It could be 0~0x1FF. Each bit corresponding to an interrupt vector:HW8~HW0

for example: invector=[HW8:HW7:HW6:HW5:HW4:HW3:HW2:HW1:HW0]

Only enable : HW0/HW3/HW5, invector=0x29 (101001B) ;

Enable all interrupt vector: invector=0x1FF (11111111B) ;

Disable all interrupt vector: invector=0x00 (000000B)

- **Include**

```
Peripheral_lib/System.h
```

- **Return Value**

0: Operation successful

1: Incorrect argument

- **Example**

```
/* Enable GIE and allows interrupts with priority 0, 1, 2,3, enableHW0~HW8. */
```

```
SYS_EnableGIE(4,0X1FF);
```

2.2.10 SYS_DisableGIE

- **Prototype**

```
void SYS_DisableGIE (void);
```

- **Description**

Disable GIE

- **Parameters**

None

- **Include**

Peripheral_lib/System.h

- **Return Value**

None

- **Example**

```
/* Disable GIE. */  
SYS_DisableGIE ( );
```

2.2.11 SYS_ LowPower

- **Prototype**

unsigned char SYS_LowPower(unsigned char umode)

- **Description**

Set up and enable the low power mode. Need to open any an interrupt vector before open low power mode and switch to a low frequency source

Set up the register 0x40104[4]

- **Parameters**

umode[in]

0: sleep mode

1: idle mode

2: waite mode

- **Include**

Peripheral_lib/System.h

- **Return Value**

0: Operation successful

1: Incorrect argument

- **Example**

```
/* Enable the sleep mode */  
DrvGPIO_Open(E_PT1,0XFF,E_IO_IntEnable); // enable PT1 external interrupt vector  
SYS_EnableGIE(7,0x3F); // Enable GIE(Global Interrupt)  
DrvCLOCK_SelectMCUClock(1,0); // switch to a low frequency source  
SYS_LowPower(0); // Enable the sleep mode
```

2.2.12 SYS_ INTPriority

- **Prototype**

unsigned char SYS_INTPriority(unsigned short intvector,unsigned short upriority);

- **Description**

Specify priority level of the corresponding interrupt. Priority level is 0~3. 0 is the highest level

Note : Before use, must disable all interrupt to modify the interrupt priority level.

- **Parameters**

intvector[in] the interrupt vector selection, input range of 0 to 8, respectively HW0 ~ HW8;;

upriority [in] set up and enable the priority level of interrupt vector, setting range is from 0 to 3

0: the highest level of priority level

1: the second highest level of priority level

2: the lower level of priority level.

3: the lowest level of priority level

When set the interrupt priority level for the same level, the order for the interrupt response:

HW0 > HW1 > HW2 > ...> HW8

- **Include**

Peripheral_lib/System.h

- **Return Value**

0: Operation successful

1: Incorrect argument

- **Example**

```
/* set the priority level of interrupt vector 0 as 1 */
```

```
SYS_INTPriority (0,1);
```

3. CLOCK Driver

3.1 Introduction

The following functions are included in Clock Manager Section.

Item	Functions	Description
01	DrvCLOCK_EnableHighOSC	Open high-speed oscillator
02	DrvCLOCK_CLOSEEHOSC	Turn off the external HSXT
03	DrvCLOCK_CLOSEIHOSC	Turn off the internal HSRC
04	DrvCLOCK_SELECTIHOSC	Select HSXT mode
05	DrvCLOCK_ENABLELOWOSC	Open low-speed oscillator
06	DrvCLOCK_CLOSEELOSC	Turn off the external LSXT
07	DrvCLOCK_SelectMCUCLOCK	Select the MCU Clock
08	DrvCLOCK_TRIMHAO	Write to the HSRC Trim value
09	DrvCLOCK_CalibrateHAO	According to the factory calibration parameters of HAO to calibrate HAO

3.2 The block diagram of CLOCK

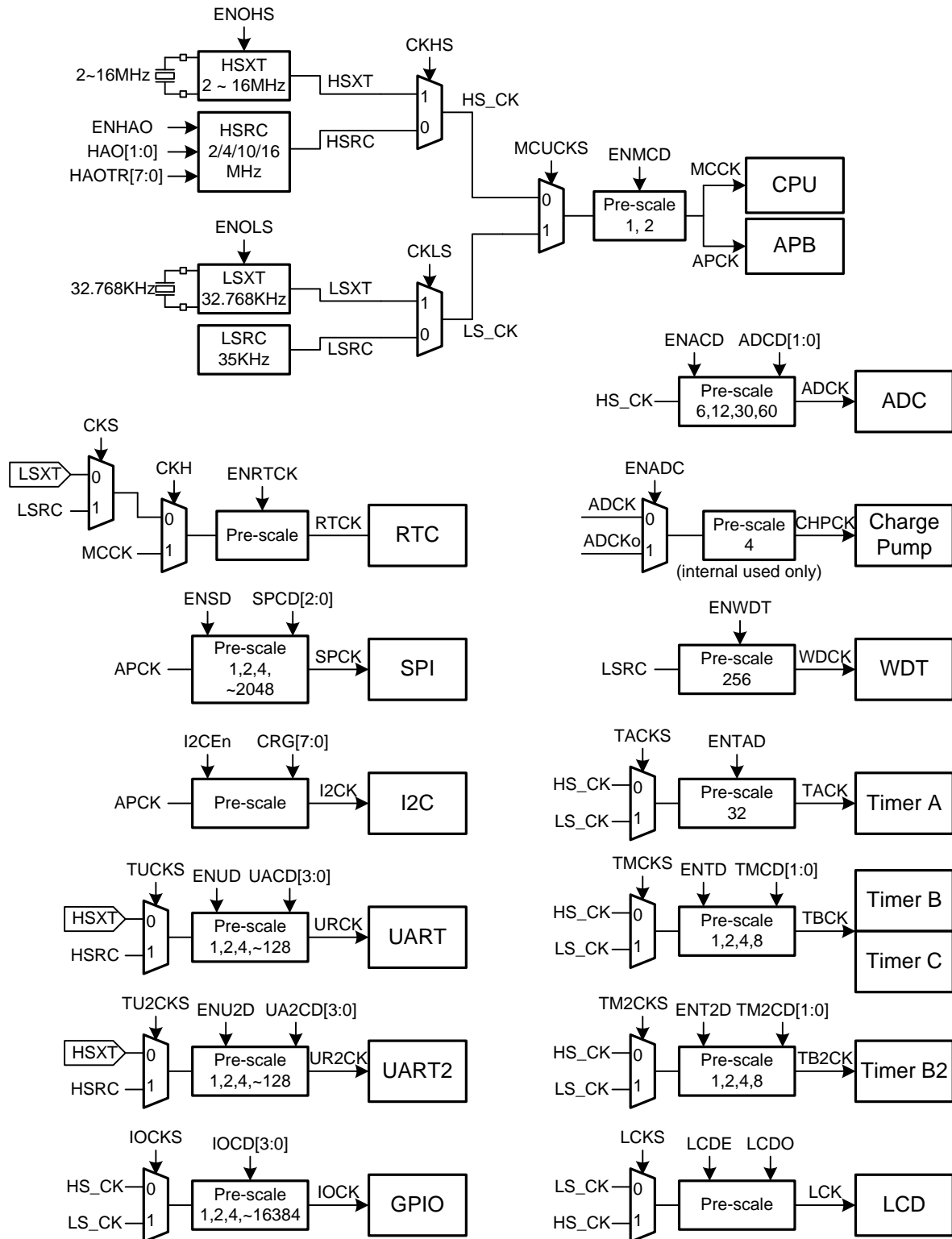

3.3 Type Definition

E_CLOCK_SOURCE

Enumeration Identifier	Value	Description
E_INTERNAL	0x0	Internal oscillator
E_EXTERNAL	0x1	External oscillator

E_TRIM_FREQUEN

Enumeration Identifier	Value	Description
TRIM_HAO2MHZ	0x0	Calibrate the frequency of HAO 2MHZ
TRIM_HAO4MHZ	0x1	Calibrate the frequency of HAO 4MHZ
TRIM_HAO10MHZ	0x2	Calibrate the frequency of HAO 10MHZ
TRIM_HAO16MHZ	0x3	Calibrate the frequency of HAO 16MHZ

3.4 Functions

3.4.1 DrvCLOCK_EnableHighOSC

- Prototype**

unsigned int DrvCLOCK_EnableHighOSC(E_CLOCK_SOURCE uSource, unsigned int delay)

- Description**

Open a high-speed oscillator, select from the external or internalSet the waiting time needed to stabilize the crystal

Configure the register 0X40300[5]=1 , 0X40300[1]=1 if the external OSC is selected as CPU clock source.

Configure the register 0X40300[5]=0 , 0X40300[0]=1 if the internal OSC is selected as CPU clock source.

- Parameter**

uSource [in]

0: Internal

1: External

delay[in] Set the waiting time needed to stabilize the crystal. Input range : 1~0xFFFFFFFF

Note that the current CPU cycles CPU_CLK, stabilization time of oscillator: $t = CPU_CLK * 4000 * delay$;

Refer to the current instruction cycle and the crystal frequency to start before set the parameter

The time needed to stabilize the EXT OSC :

4MHZ/8MHZ about 30ms

The time needed to stabilize the HAO :

2MHZ about 1.0ms

4MHZ about 0.5ms

10MHZ about 0.2ms

20MHZ about 0.1ms

- Include**

Peripheral_lib/DrvCLOCK.h

- Return Value**

0: Operation successful

1: Incorrect argument

- **Example**

```
/* Open external high-speed oscillator, current CPU_CK=10MHZ/2, Open external 4MHZ, Delay 40ms
=(1/10MHZ/2)*4000*50*/
DrvCLOCK_EnableHighOSC (E_EXTERNAL,50);
```

3.4.2 DrvCLOCK_CloseEHOSC

- **Prototype**

```
void DrvCLOCK_CloseEHOSC()
```

- **Description**

Turn off the external high-speed oscillator . Need to turn on a available clock source before turn off the external high-speed oscillator if the external high-speed oscillator is the CPU clock source.

Configure the register 0x40300[1]=0

- **Parameter**

None

- **Include**

Peripheral_lib/DrvCLOCK.h

- **Return Value**

None

- **Example**

```
/*Turn off the external high-speed oscillator*/
DrvCLOCK_EnableHighOSC (E_INTERNAL,50); //Open internal high-speed oscillator
DrvCLOCK_CloseEHOSC(); //Turn off the external high-speed oscillator
```

3.4.3 DrvCLOCK_CLOSEIHOSC

- **Prototype**

```
void DrvCLOCK_CloseIHOSC()
```

- **Description**

Turn off the internal high-speed oscillator before switching the CPU clock source to available source

Configure the register 0x40300[0]=0

- **Parameter**

None

- **Include**

Peripheral_lib/DrvCLOCK.h

- **Return Value**

None

- **Example**

```
/* Turn off the internal high-speed oscillator that is the CPU clock source*/  
DrvCLOCK_EnableHighOSC (E_EXTERNAL,50); // Open external high-speed oscillator  
DrvCLOCK_CloseIHOSC();
```

3.4.4 DrvCLOCK_SELECTIHOSC

- **Prototype**

unsigned int DrvCLOCK_SelectIHOSC(uMode)

- **Description**

Select high-speed internal oscillator mode
Configure the register 0x40300[4:3]

- **Parameter**

uMode [in]
0 : 2MHz
1 : 4MHz
2 : 10MHz
3 : 16MHz

- **Include**

Peripheral_lib/DrvCLOCK.h

- **Return Value**

0: Operation successful
other: Incorrect argument

- **Example**

```
/* Select high-speed internal oscillator 4MHz mode*/  
DrvCLOCK_SelectIHOSC (1);
```

3.4.5 DrvCLOCK_ENABLELOWOSC

- **Prototype**

unsigned int DrvCLOCK_EnableLowOSC(E_CLOCK_SOURCE uSource , uint delay)

- **Description**

Open the low-speed oscillator; select the oscillator from an external or internal. Set the waiting time needed to stabilize the crystal

Configure the register 0x40300[6]=1 0x40300[2]=1 0x40300[4:3]=xxb

- **Parameter**

uSource [in]

0: Internal

1: External

delay[in] Set the waiting time needed to stabilize the crystal. Need to refer to the current instruction cycle.

Input range: 0~0xFFFFFFFF

The time needed to stabilize the EXT OSC : 32768HZ about 1.3s

The time needed to stabilize the internal OSC : about 510us

- **Include**

Peripheral_lib/DrvCLOCK.h

- **Return Value**

0: Operation successful

1: Incorrect argument

- **Example**

```
/* Open the external low-speed oscillator, set the delay time */
```

```
DrvCLOCK_EnableLowOSC (E_EXTERNAL,130000);
```

3.4.6 DrvCLOCK_CLOSEELOSC

- **Prototype**

```
void DrvCLOCK_CloseELOSC()
```

- **Description**

Turn off the external low-speed oscillator

Configure the register 0x40300[2]=0

- **Parameter**

None

- **Include**

Peripheral_lib/DrvCLOCK.h

- **Return Value**

None

- **Example**

```
/*Turn off the external low-speed oscillator*/
```

```
DrvCLOCK_EnableLowOSC (E_INTERNAL,130000); //turn on internal low-speed oscillator
```

```
DrvCLOCK_CloseELOSC();
```

3.4.7 DrvCLOCK_SelectMCUClock

- **Prototype**

```
unsigned int DrvCLOCK_SelectMCUClock(uSource,uDiv)
```

- **Description**

Select the MCU Clock from HS_CK, or LS_CK and Pre-scale

- **Parameter**

uSource [in]

0 : HS_CK

1 : LS_CK

uDiv [in]

0 : ÷1

1 : ÷2

- **Include**

Peripheral_lib/DrvCLOCK.h

- **Return Value**

0: Operation successful

other: Incorrect argument

- **Example**

```
/* Select the MCU Clock from HS_CK and Pre-scale 2 */
```

```
DrvCLOCK_SelectIHOSC (0, 1);
```

3.4.8 DrvCLOCK_TRIMHAO

- **Prototype**

```
unsigned int DrvCLOCK_TrimHAO(uTrim)
```

- **Description**

Write to the internal oscillator Trim value

Configure the register 0x40304[7:0]

- **Parameter**

uTrim [in] the internal oscillator Trim value

0~255

- **Include**

Peripheral_lib/DrvCLOCK.h

- **Return Value**

0: Operation successful

other: Incorrect argument

- **Example**

```
/*Write 0X80 to the internal oscillator Trim value*/
```

```
DrvCLOCK_TrimHAO(0x80);
```

3.4.9 DrvCLOCK_CalibrateHAO

- **Prototype**

void DrvCLOCK_CalibrateHAO(short int uMHZ)

- **Description**

According to the factory calibration parameters of HAO to calibrate HAO, and need to corresponding to the selected HAO frequency.

Configure the register 0x40304[7:0]

- **Parameter**

uMHZ [in] the HAO frequency to calibrate

0: calibrate 2MHZ 1: calibrate 4MHZ 2 calibrate10MHZ 3: calibrate 16MHZ

- **Include**

Peripheral_lib/DrvCLOCK.h

- **Return Value**

None

- **Example**

```
/* calibrate internal OSC 4MHZ*/  
DrvCLOCK_SelectIHOSC(1); //setting HAO=4MHZ;  
DrvCLOCK_CalibrateHAO(1); //calibrate 4MHZ;
```

4. TIMER/WDT Driver

4.1 Introduction

The following functions are included in Timer Manager Section.

Item	Functions	Description
01	DrvWDT_Open	Open WDT
02	DrvWDT_COUNTERREAD	Read the current WDT counter
03	DrvWDT_CLEARWDT	Watch dog timer clear
04	DrvTMA_Open	Enable timer A
05	DrvTMA_Close	Close timer A
06	DrvTMA_COUNTER_READ	Read the current TMA counter
07	DrvTMA_CLEAR_TMA	Clear Timer A
08	DrvTIMER_EnableInt	Enable the specified timer interrupt.
09	DrvTIMER_DisableInt	Disable the specified timer interrupt
10	DrvTIMER_GetIntFlag	Get the interrupt flag status
11	DrvTIMER_ClearIntFlag	Clear the interrupt flag
12	DrvTMB_Open	Enable timer B
13	DrvTMB_CLOCKSOURCE	Timer B,C clock source selection
14	DrvTMB_CLOCKDISABLE	Disable timer B,C clock
15	DrvTMA_CLEAR_TMB	Clear Timer B
16	DrvTMB_COUNTERREAD	Read the current TMB counter
17	DrvTMB_Close	Close timer B
18	DrvPWM0_Open	Enable PWM and PWM0 mode
19	DrvPWM1_Open	Enable PWM and PWM1 mode
20	DrvPWM_COUNTCONDITION	PWM count condition parameter
21	DrvPWM0_Close	PWM0 off
22	DrvPWM1_Close	PWM1 off
23	DrvCAPTURE1_Open	Enable Capture1
24	DrvCAPTURE2_Open	Enable Capture2
25	DrvCAPTURE1_READ	Read Capture1 counter
26	DrvCAPTURE2_READ	Read Capture2 counter
27	DrvCAPTURE_IPORT	Select the capture input pin
28	DrvTMB_TCI1Edge	Select the trigger mode of TMB TCI1 input port
29	DrvTMB_CPI1Input	Set the input source in the mode of TMB CPI1
30	DrvTMB2_Open	Set TMB2
31	DrvTMB2_Close	Disable TMB2
32	DrvTMB2_Clk_Source	Set TMB2 clock source
33	DrvTMB2_Clk_Disable	Disable TMB2 clock source
34	DrvTMB2_ClearTMB	Clear the counting register of Timer B2
35	DrvTMB2_CounterRead	Read the current TMB2 counter
36	DrvPWM2_Open	Enable PWM2 and operation mode selection
37	DrvPWM3_Open	Enable PWM3 and operation mode selection
38	DrvTMB2PWM_CountCondition	Set PWM2/PWM3 count condition parameter
39	DrvPWM2_Close	Disable PWM2
40	DrvPWM3_Close	Disable PWM3
41	DrvTMB2_CPI3Input	Set the input source in the mode of TMB2 CPI3
42	DrvTMB2_TCI3Edge	Select the trigger method of TMB2 TCI3 input source

4.2 The functional block diagram

4.2.1 The block diagram of WDT

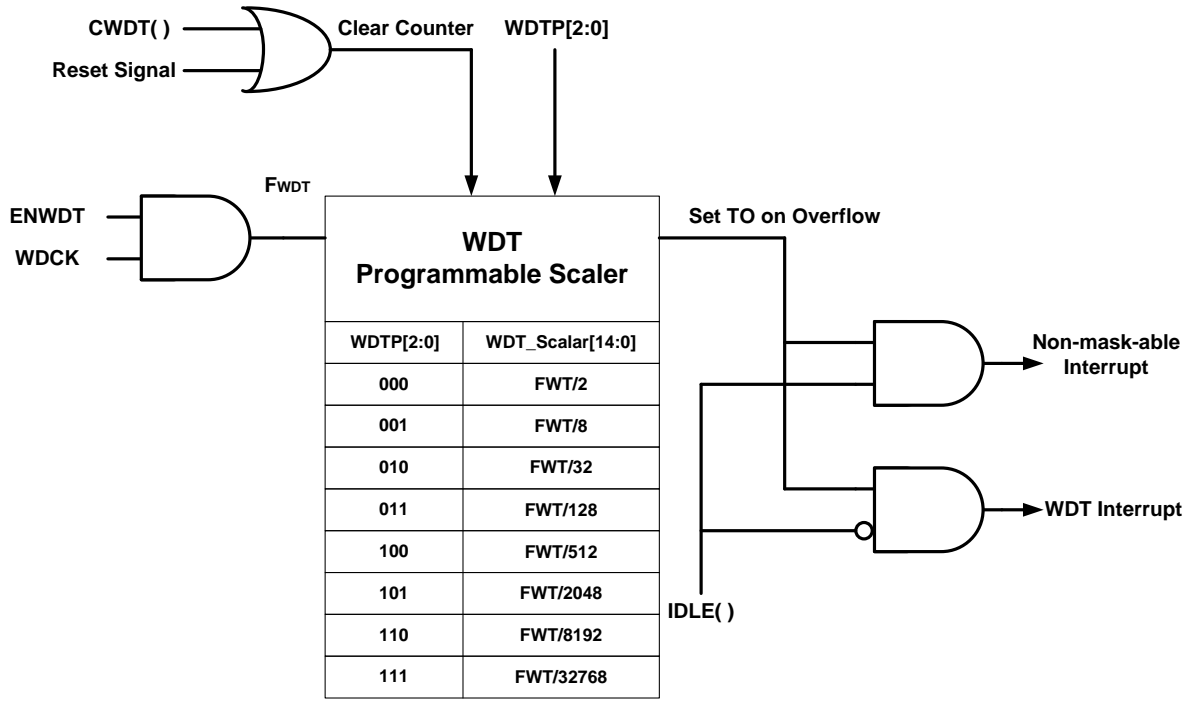

4.2.2 The block diagram of Timer A

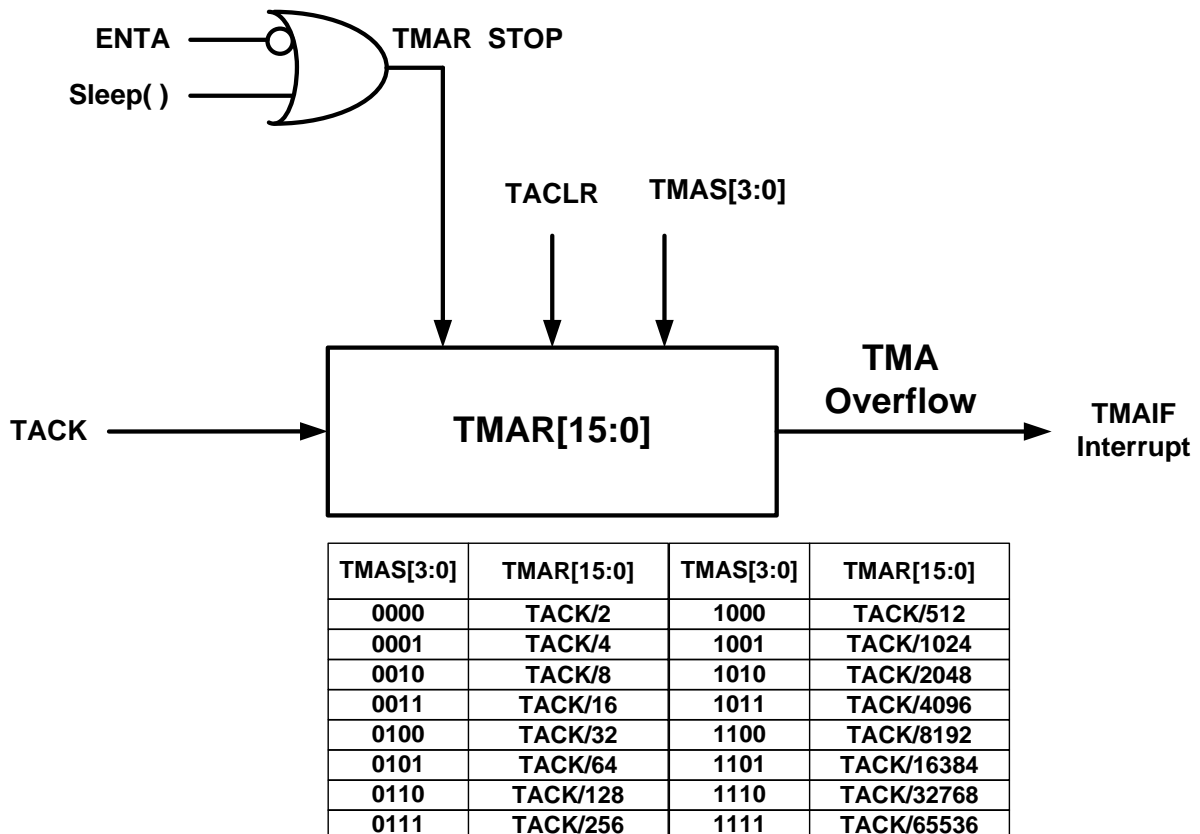

4.2.3 The block diagram of Timer B

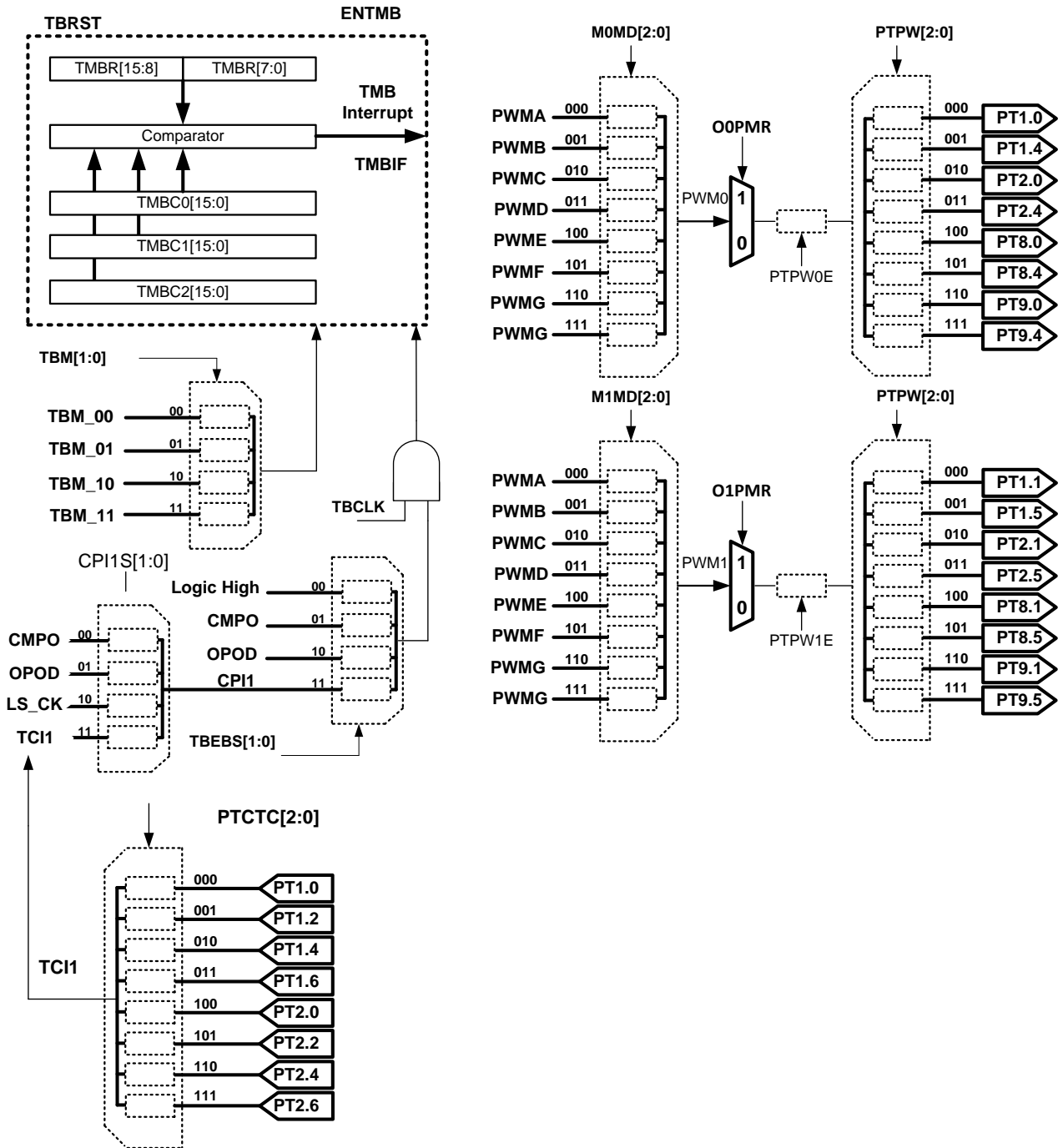

4.2.4 The block diagram of Timer C

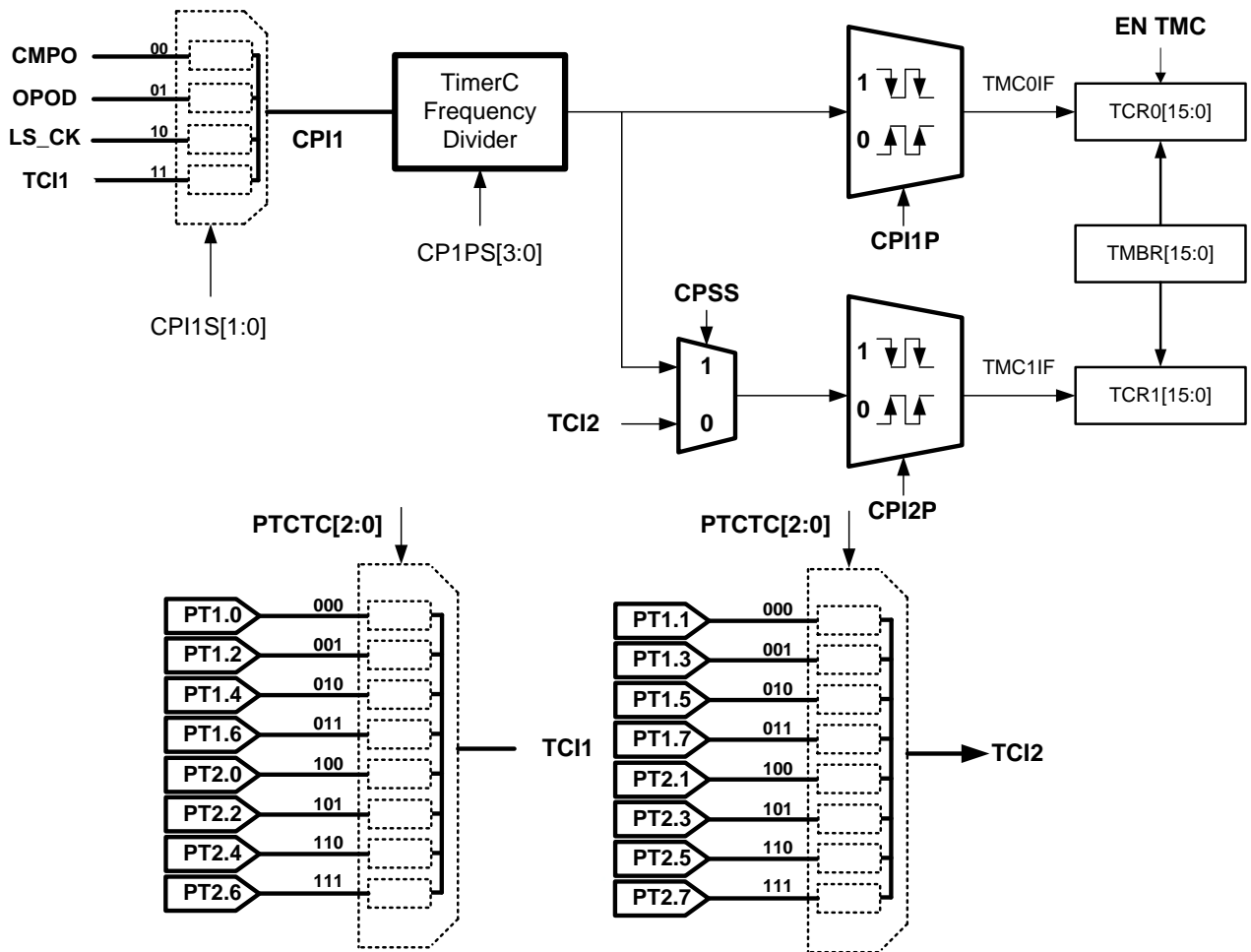

CP1PS[3:0]	CPI1 Divider	CP1PS[3:0]	CPI1 Divider
0000	CPI1/1	1000	CPI1/256
0001	CPI1/2	1001	CPI1/512
0010	CPI1/4	1010	CPI1/1024
0011	CPI1/8	1011	CPI1/2048
0100	CPI1/16	1100	CPI1/4096
0101	CPI1/32	1101	CPI1/8192
0110	CPI1/64	1110	CPI1/16384
0111	CPI1/128	1111	CPI1/32768

4.2.4 The block diagram of Timer B2

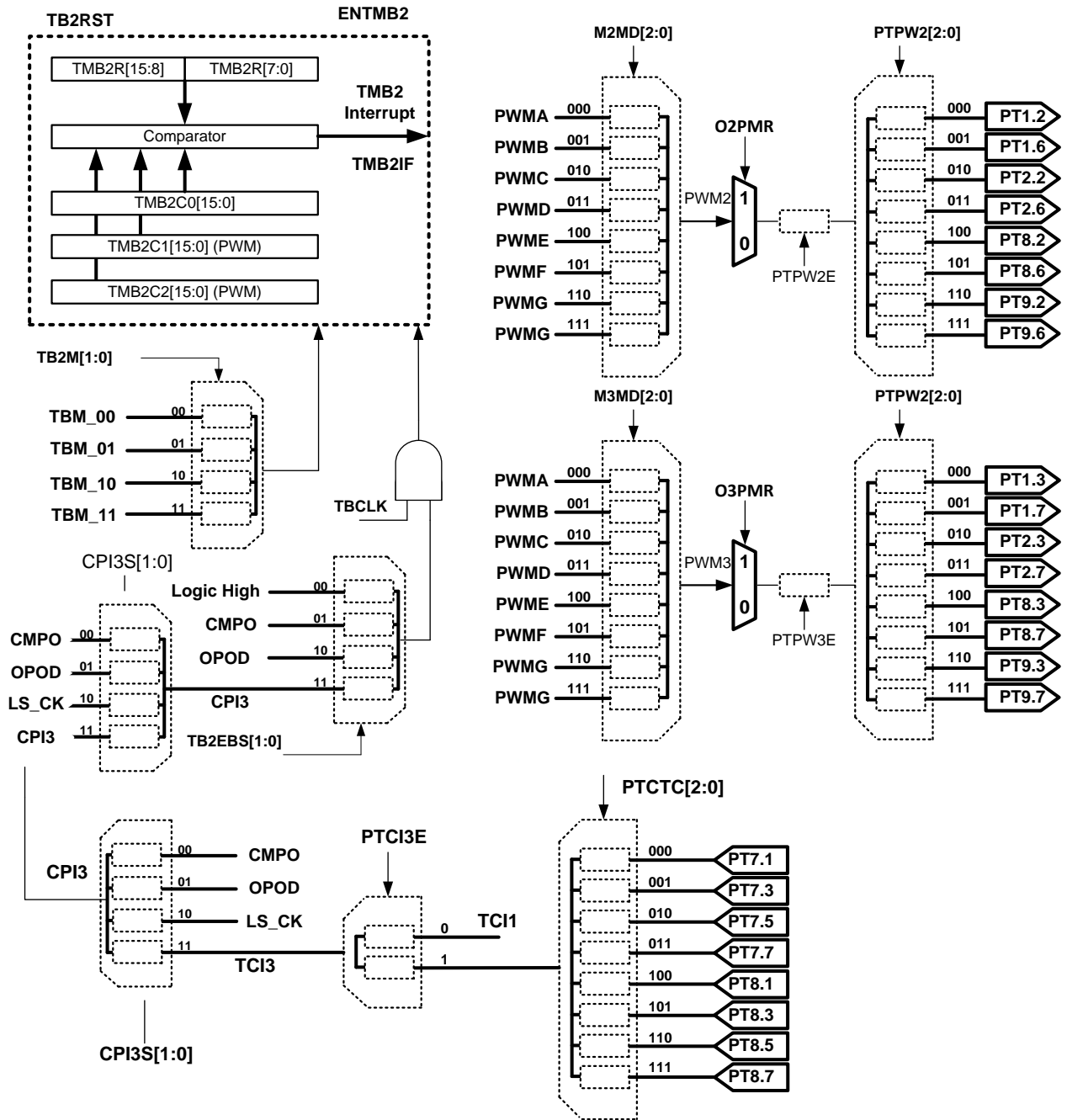

4.3 Type Definition

E_WDT_MODE

Enumeration Identifier	Value	Description
E_IRQ	0x0	IRQ mode
E_RST	0x1	RESET mode

E_WDT_PRE_SCALER

Enumeration Identifier	Value	Description
E_PRE_SCALER_D2	0x0	WDT_CK / 2
E_PRE_SCALER_D8	0x1	WDT_CK / 8
E_PRE_SCALER_D32	0x2	WDT_CK / 32
E_PRE_SCALER_D128	0x3	WDT_CK / 128
E_PRE_SCALER_D512	0x4	WDT_CK / 512
E_PRE_SCALER_D2048	0x5	WDT_CK / 2048
E_PRE_SCALER_D8192	0x6	WDT_CK / 8192
E_PRE_SCALER_D32768	0x7	WDT_CK / 32768

E_TIMER_CHANNEL

Enumeration Identifier	Value	Description
E_TMA	0x0	Specify the timer channel – A
E_TMB	0x1	Specify the timer channel – B
E_TMC0	0x2	Specify the timer channel - C
E_TMC1	0x3	Specify the timer channel - C
E_WDT	0x4	Specify the timer channel - WDT
E_TMB2	0x5	Specify the timer channel – B2

E_TMB_MODE

Enumeration Identifier	Value	Description
E_TMB_MODE0	0x0	16-bit saw tooth waveform count up TBC0 for the maximum limit
E_TMB_MODE1	0x1	16-bit triangular waveform up and down the count range of 0 to TBC0
E_TMB_MODE2	0x2	The two independent 8-bit saw tooth type count, up to TBC0 bit 15-8 and bit 7-0 for the maximum limit
E_TMB_MODE3	0x3	The two 8-bit saw tooth type count, TBR[15:0] will be automatically added by 1, only after TBR[7:0] overflow

E_TRIGGER_SOURCE

Enumeration Identifier	Value	Description
E_TMB_NORMAL	0x0	Always Enable
E_TMB_CMP_HIGH	0x1	CMP high trigger
E_TMB_OP_HIGH	0x2	OP high trigger
E_TMB_GPIO_HIGH	0x3	GPIO high trigger

E_DRVTIMER_CLOCK_SOURCE

Enumeration Identifier	Value	Description
E_HS_CK	0	TMA clock source from HS_CK
E_LS_CK	1	TMA clock source from LS_CK

E_CAPTURE_SOURCE

Enumeration Identifier	Value	Description
E_TMC_CMPO	0x0	Comparator output
E_TMC_OPOD	0x1	Rail-to-rail OP amp digital output
E_TMC_LSCK	0x2	Low speed clock source
E_TMC_TCI0	0x3	TC1 form I/O port
E_TMC_TCI1	0x0	TC2 form I/O port
E_TMC_ASTC0	0x1	Inupt source of TC2 is the same as TC1

4.4 Functions

4.4.1 DrvWDT_Open

- **Prototype**

uint32_t DrvWDT_Open (E_WDT_MODE eMode , E_WDT_PRE_SCALER eWDTpreScaler)

- **Description**

Enable WDT engine clock and set WDT time-out interval and set WDT mode.

Configure the register 0x40108[7:0]

- **Parameter**

eMode [in] the operating mode of WDT

0 : Timer mode

1 : Reset mode

eWDTpreScaler [in] the prescaler of WDT clock source

0 : WDT_CK / 2

1 : WDT_CK / 8

2 : WDT_CK / 32

3 : WDT_CK / 128

4 : WDT_CK / 512

5 : WDT_CK / 2048

6: WDT_CK / 8192

7: WDT_CK / 32768

- **Include**

Peripheral_lib/DrvTIMER.h

- **Return Value**

0: Operation successful

1: WDT open fail

- **Example**

```
/* Set the WDT in IRQ mode and CLK / 32 */
```

```
DrvWDT_Open (E_IRQ , E_PRE_SCALER_D32);
```

4.4.2 DrvWDT_COUNTERREAD

- **Prototype**

```
uint32_t DrvWDT_CounterRead (void)
```

- **Description**

Read the current WDT counter.

Read the register 0x40108

- **Parameter**

None

- **Include**

Peripheral_lib/DrvTIMER.h

- **Return Value**

The return values of WDT counter.

- **Example**

```
Unsigned int data; data=DrvWDT_CounterRead ();
```

4.4.3 DrvWDT_CLEARWDT

- **Prototype**

```
void DrvWDT_ClearWDT (void)
```

- **Description**

Watch dog timer clear.

Configure the register 0x40108[5]=1, and automatically becomes 0 after clear.

- **Parameter**

None

- **Include**

Peripheral_lib/DrvTIMER.h

- **Return Value**

None

- **Example**

```
/* Watch dog timer clear. */
```

```
DrvWDT_ClearWDT ();
```

4.4.4 DrvTMA_Open

- **Prototype**

unsigned int DrvTMA_Open (eTMAOV, E_DRVTIMER_CLOCK_SOURCE uclk)

- **Description**

Enable timerA ,set counter value and clock source of TMA.

Configure the register 0X40C00[5]=1, 0X40C00[3:0], 0X40308[3], 0X40308[2]=1

- **Parameter**

eTMAOV [in]

Specify timer A overflow condition.

0 : taclk/2

1 : taclk/4

2 : taclk/8

3 : taclk/16

4 : taclk/32

5 : taclk/64

6 : taclk/128

7 : taclk/256

8 : taclk/512

9 : taclk/1024

10 : taclk/2048

11 : taclk/4096

12 : taclk/8192

13 : taclk/16384

14 : taclk/32768

15: taclk/65536

Uclk[in]

Specify timer A clock source.

0: HS_CK

1: LS_CK

- **Include**

Peripheral_lib/DrvTIMER.h

- **Return Value**

0: Operation successful

Other : Incorrect argument

- **Example**

```
/* Enable timerA and set counter value is taclk/8. */
```

```
DrvTMA_Open (2,0);
```

4.4.5 DrvTMA_Close

- **Prototype**

void DrvTMA_Close (void)

- **Description**

Close timerA

Configure the register 0x40C00[5]=0

- **Parameter**

None

- **Include**

Peripheral_lib/DrvTIMER.h

- **Return Value**

None

- **Example**

```
/* Disable timerA */  
DrvTMA_Close ();
```

4.4.6 DrvTMA_COUNTERREAD

- **Prototype**

unsigned int DrvTMA_CounterRead (void)

- **Description**

Read the current TMA counter.

Read the register 0x40C00[15:0]

- **Parameter**

None

- **Include**

Peripheral_lib/DrvTIMER.h

- **Return Value**

The return values of TMA counter.

- **Example**

```
/* Read the current TMA counter */  
unsigned short tcounter; tcounter=DrvTMA_CounterRead ();
```

4.4.7 DrvTMA_CLEAR_TMA

- **Prototype**

void DrvTMA_ClearTMA (void)

- **Description**

Clear Timer A.

Configure the register 0x40C00[4]=1, and automatically becomes 0 after clear.

- **Parameter**

None

- **Include**

Peripheral_lib/DrvTIMER.h

- **Return Value**

None

- **Example**

```
/* Clear Timer A. */  
DrvTMA_ClearTMA();
```

4.4.8 DrvTIMER_EnableInt

- **Prototype**

unsigned int DrvTIMER_EnableInt (E_TIMER_CHANNEL ch)

- **Description**

This function is used to enable the specified timer interrupt.

Configure the corresponding bit of register 0x40004[20:16] ,0x4001C[17]

- **Parameter**

ch [in] interrupt source

0: TMA 1: TMB 2: TMC C0

3: TMC C1 4: WDT 5:TMB2

- **Include**

Peripheral_lib/DrvTIMER.h

- **Return Value**

0: Operation successful

Other : Invalid

- **Example**

```
/* Enable Timer-A interrupt function */  
DrvTIMER_EnableInt (E_TMA);
```

4.4.9 DrvTIMER_DisableInt

- **Prototype**

unsigned int DrvTIMER_DisableInt (E_TIMER_CHANNEL ch)

- **Description**

This function is used to disable the specified timer interrupt.

Configure a corresponding bit of register 0x40004[20:16] ,0x4001C[17]

- **Parameter**

ch [in]

TIMER_CHANNELselection

0: TMA 1: TMB 2: TMC C0

3: TMC C1 4: WDT 5:TMB2

- **Include**

Peripheral_lib/DrvTIMER.h

- **Return Value**

0: Operation successful

Other : Invalid

- **Example**

```
/* Disable Timer-A interrupt function */
```

```
DrvTIMER_DisableInt (E_TMA);
```

4.4.10 DrvTIMER_GetIntFlag

- **Prototype**

unsigned int DrvTIMER_GetIntFlag (E_TIMER_CHANNEL ch)

- **Description**

Get the interrupt flag status from the specified timer channel.

Configure a corresponding bit of register 0x40004[4:0] /0x4001C[1]

- **Parameter**

ch [in]

E_TIMER_CHANNEL, it could be E_TMA / E_TMB / E_TMC

0: TMA 1: TMB 2: TMC C0

3: TMC C1 4: WDT 5: TMB

- **Include**

Peripheral_lib/DrvTIMER.h

- **Return Value**

0: No interrupt

1: Interrupt occurred

- **Example**

```
/* Get the interrupt flag status from Timer-A */  
DrvTIMER_GetIntFlag (E_TMA);
```

4.4.11 DrvTIMER_ClearIntFlag

- **Prototype**

unsigned int DrvTIMER_ClearIntFlag (E_TIMER_CHANNEL ch)

- **Description**

Clear the interrupt flag of the specified timer channel.

Configure a corresponding bit of register 0x40004[4:0]/0x4001C[17]

- **Parameter**

ch [in]

E_TIMER_CHANNEL, it could be E_TMA / E_TMB / E_TMC

0: TMA 1: TMB 2: TMC C0

3: TMC C1 4: WDT 5: TMB2

- **Include**

Peripheral_lib/DrvTIMER.h

- **Return Value**

0: Operation successful

Other : Invalid

- **Example**

```
/* Clear Timer-A interrupt flag */  
DrvTIMER_ClearIntFlag (E_TMA);
```

4.4.12 DrvTMB_Open

- **Prototype**

Unsigned int DrvTMB_Open (E_TMB_MODE eTMBmode, E_TRIGGER_SOURCE eTriSource, eTMBOV)

- **Description**

Enable TMB and set TMB counter value and TMB mode and trigger source. Support compare and capture and counting and timing functions.

Configure the register 0X40C0C BIT TBC0[15:0], 0X40C04[3:0] / 0X40C04[5]

- **Parameter**

eTMBmode [in]

Specify timer B counting mode.

0: TBR is in UP mode. In the UP mode, the TBR is increase by 1 for every positive edge of TBCLK.

If it is larger than TBC0, TBR changes to 0 for next positive edge of TBCK and TMBIF is change to 1. Then, TBR starts to up count again.

1: TBR is in UP/Down mode. In the UP mode, the TBR is increase by 1 for every positive edge of TBCLK.

If it is equal to TBC0, TBR changes to down mode and TMR become to decrease by 1 for every positive edge of TBCK. Until TBR down count to 0, TMBIF changes to 1 and TBR starts to up count again.

2: TBR is in two 8-bit PWM mode. The TBR is broke to two independent 8-bit UP counters: TBR[15:8] and TBR[7:0]. The TBR[15:8] up limit is controlled by TBC[15:8] and TBR[7:0] up limit is controlled by TBC[7:0]. Both of the TBRs are increase by 1 for every positive edge of TBCLK. If TBR[15:8] is equal to TBC0[15:8], then the next positive edge of TBCLK would make TBR[15:8] to be 0. TMBIF still remains 0. If TBR[7:0] is equal to TBC0[7:0], then the next positive edge of TBCLK would make TBR[7:0] to be 0. TMBIF changes to 1.

3: TBR is in step increment mode. TBR is break into two counters TBR[15:8] and TBR[7:0]. Both of them are in Up mode. However, the limit of TBR[7:0] is controlled by TBC0[7:0]. The TBR[7:0] is increase by 1 for every positive edge of TBCLK. If TBR[7:0] is equal to TBC0[7:0], then it would change to 0 at next positive edge of TBCLK. Moreover, the TMBIF changes to 1 and TBR[15:8] increases by 1.

eTriSource [in]

Specify TMB trigger source.

0: Always Enable

1: CMP high trigger

2: OP high trigger

3:TMC output high trigger (CPI1)

eTMAOV [in]

Specify overflow condition. (0~0xffff)

- **Include**

Peripheral_lib/DrvTIMER.h

- **Return Value**

0: Operation successful

Other : Incorrect argument

- **Example**

```
/* Enable timerB mode1 and set counter value is taclk/32 and trigger form OP. */
```

```
DrvTMB_Open (E_TMB_MODE0, E_TMB_OP_HIGH,4);
```

4.4.13 DrvTMBC_CLK_SOURCE

- **Prototype**

unsigned int DrvTMBC_Clk_Source (E_DRVTIMER_CLOCK_SOURCE uclk, uPerScale)

- **Description**

Timer B,C clock source selection and clock divider selection.

Configure the register 0x40308[7:4]

- **Parameter**

uclk[in]

Specify timer B,C clock source.

0: HS_CK

1: LS_CK

uPerScale [in]

Specify timer B,C clock divider.

0: ÷1

1: ÷2

2: ÷4

3: ÷8

- **Include**

Peripheral_lib/DrvTIMER.h

- **Return Value**

0: Operation successful

Other : Incorrect argument

- **Example**

```
/* Select the timer B clock from HS_CLK, divider of 2. */
```

```
DrvTMB_Clk_Source (0,1);
```

4.4.14 DrvTMBC_CLK_DISABLE

- **Prototype**

viod DrvTMBC_Clk_Disable (viod)

- **Description**

Disable timer B,C clock.

Configure the register 0x40308[6]=0

- **Parameter**

None

- **Include**

Peripheral_lib/DrvTIMER.h

- **Return Value**

None

- **Example**

```
/* Disable timer B,C clock.*/
```

```
DrvTMBC_Clk_Disable ();
```

4.4.15 DrvTMA_CLEAR_TMB

- **Prototype**

void DrvTMA_ClearTMB (void)

- **Description**

Clear Timer B.

Configure the register 0x40C04[4]=1, and automatically change to 0 after clear.

- **Parameter**

None

- **Include**

Peripheral_lib/DrvTIMER.h

- **Return Value**

None

- **Example**

```
/* Clear Timer B counter */  
DrvTMB_ClearTMB();
```

4.4.16 DrvTMB_COUNTER_READ

- **Prototype**

unsigned int DrvTMB_CounterRead (void)

- **Description**

Read the current TMB counter.

Read the register 0x40C08[15:0]

- **Parameter**

None

- **Include**

Peripheral_lib/DrvTIMER.h

- **Return Value**

The return values of TMB counter.

- **Example**

```
/* Read the current TMB counter */  
unsigned short tcounter; tcounter=DrvTMB_CounterRead ();
```

4.4.17 DrvTMB_Close

- **Prototype**

void DrvTMB_Close (void)

- **Description**

Close timer B

Configure the register 0x40C04[5]=0

- **Parameter**

None

- **Include**

Peripheral_lib/DrvTIMER.h

- **Return Value**

None

- **Example**

```
/* Disable timerB */  
DrvTMB_Close ();
```

4.4.18 DrvPWM0_Open

- **Prototype**

unsigned int DrvPWM0_Open (uPWM_Mode , ulnv, uOutputPin)

- **Description**

Enable PWM and PWM0 operation mode selection. Select IO port to output. PWM output inverse control

Configure the register 0X40C04[18:16] / 0X40C04[19], 0X40840[4:2] / 0X40840[0]

- **Parameter**

uPWM_Mode [in]

PWM Operation mode selection

0: PWM A 1: PWM B

2: PWM C 3: PWM D

4 : PWM E 5 : PWM F

6 : PWM G 7 : PWM G

ulnv[in]

PWM output inverse control.

0 : inverse

1 : Normal

uOutputPin[in]

0 : Port 1.0 =PWMO0, Port 1.1 =PWMO1

1 : Port 1.4 =PWMO0, Port 1.5 =PWMO1

2 : Port 2.0 =PWMO0, Port 2.1 =PWMO1

3 : Port 2.4 =PWMO0, Port 2.5 =PWMO1

4 : Port 8.0 =PWMO0, Port 8.1 =PWMO1

5 : Port 8.4 =PWMO0, Port 8.5 =PWMO1

6 : Port 9.0 =PWMO0, Port 9.1 =PWMO1

7 : Port 9.4 =PWMO0, Port 9.5 =PWMO1

- **Include**

Peripheral_lib/DrvTIMER.h

- **Return Value**

0: Operation successful

Other : Incorrect argument

- **Example**

```
/* Enable PWM, PWM0 working in PWMA mode, the reverse signal. */
```

```
DrvPWM0_Open (0, 0, 0);
```

4.4.19 DrvPWM1_Open

- **Prototype**

```
unsigned int DrvPWM1_Open (uPWM_Mode , ulnv, uOutputPin)
```

- **Description**

Enable PWM and PWM1 operation mode selection. Select IO port to output. PWM output inverse control

- **Parameter**

uPWM_Mode [in]

PWM operation mode selection

0: PWM A 1: PWM B

2: PWM C 3: PWM D

4 : PWM E 5 : PWM F

6 : PWM G 7 : PWM G

ulnv[in]

PWM output inverse control..

0 : inverse

1 : Normal

uOutputPin[in]

0 : Port 1.0 =PWMO0, Port 1.1 =PWMO1

1 : Port 1.4 =PWMO0, Port 1.5 =PWMO1

2 : Port 2.0 =PWMO0, Port 2.1 =PWMO1

3 : Port 2.4 =PWMO0, Port 2.5 =PWMO1

4 : Port 8.0 =PWMO0, Port 8.1 =PWMO1

5 : Port 8.4 =PWMO0, Port 8.5 =PWMO1

6 : Port 9.0 =PWMO0, Port 9.1 =PWMO1

7 : Port 9.4 =PWMO0, Port 9.5 =PWMO1

- **Include**

Peripheral_lib/DrvTIMER.h

- **Return Value**

0: Operation successful

Other : Incorrect argument

- **Example**

```
/* Enable PWM, PWM1 working in PWMA mode, the reverse signal. */
```

```
DrvPWM1_Open (0, 0, 0);
```

4.4.20 DrvPWM1_COUNT_CONDITION

- **Prototype**

```
void DrvPWM_CountCondition (uTBC2, uTBC1)
```

- **Description**

PWM count condition parameter (TBC2, TBC1) setting.

Configure the register 0X40C10[15:0](TBC1) / 0X40C10[15:0](TBC2)

- **Parameter**

uTBC1 [in]

Specify the TBC1 Condition. (0~65535)

uTBC2 [in]

Specify the TBC2 Condition. (0~65535)

- **Include**

Peripheral_lib/DrvTIMER.h

- **Return Value**

None

- **Example**

```
/* Set TBC1, TBC2 value of 0x4000 */
```

```
DrvPWM_CountCondition (0x4000,0x4000);
```

4.4.21 DrvPWM0_Close

- **Prototype**

```
void DrvPWM0_Close (void)
```

- **Description**

PWM0 off

Configure the register 0x40840[0]

- **Parameter**

None

- **Include**

Peripheral_lib/DrvTIMER.h

- **Return Value**

None

- **Example**

```
/*PWM0 off */  
DrvPWM0_Close ();
```

4.4.22 DrvPWM1_Close

- **Prototype**

void DrvPWM1_Close (void)

- **Description**

PWM1 off
Configure the register 0x40840[1]

- **Parameter**

None

- **Include**

Peripheral_lib/DrvTIMER.h

- **Return Value**

None

- **Example**

```
/*PWM1 off */  
DrvPWM1_Close ();
```

4.4.23 DrvCAPTURE1_Open

- **Prototype**

unsigned int DrvCapture1_Open (CAPTURE_SOURCE uChannel , uDivider, uEdge)

- **Description**

Enable Capture1, Selected the input sources, pre-scale, the trigger source control.
Configure the register 0X40C14[21:16] / 0X40C14[1] / 0X40C14[0]

- **Parameter**

uChannel [in]
Capture 1 input source selection.
0 : CMPO
1 : OPOD
2 : LS_CK

3 : TCI1

uDivider [in]

Input clock prescale.

0: ÷1 8: ÷256

1: ÷2 9: ÷512

2: ÷4 10: ÷1024

3: ÷8 11: ÷2048

4: ÷16 12: ÷4096

5: ÷32 13: ÷8192

6: ÷64 14: ÷16384

7: ÷128 15: ÷32768

uEdge [in]

0 : Negative-edge trigger

1 : Positive-edge trigger

- **Include**

Peripheral_lib/DrvTIMER.h

- **Return Value**

0: Operation successful

Other : Incorrect argument

- **Example**

```
/* Enable capture1, Choose TCI1 input , divided by 2048 , positive-edge trigger */
```

```
DrvCapture1_Open (3, 11, 0);
```

4.4.24 DrvCAPTURE2_Open

- **Prototype**

unsigned int DrvCapture2_Open (CAPTURE_SOURCE uChannel, uEdge)

- **Description**

Enable Capture2, Selected the input sources, pre-scale, the trigger source control.

Configure the register 0X40C14[21:16] / 0X40C14[1] / 0X40C14[0]

- **Parameter**

uChannel [in]

Capture 2 input source selection.

0:TCI2 from GPIO

1: With the Channel1 the same trigger source

uEdge [in]

0: Negative-edge trigger

1: Positive-edge trigger

- **Include**

Peripheral_lib/DrvTIMER.h

- **Return Value**

0: Operation successful

Other : Incorrect argument

- **Example**

```
/* Enable capture2, Choose TCI1 input , divided by 2048 , positive-edge trigger */
```

```
DrvCapture2_Open (1, 0);
```

4.4.25 DrvCAPTURE1_READ

- **Prototype**

unsigned int DrvCapture1_Read (void)

- **Description**

Read Capture1 counter.

Configure the register 0X40C18[15:0]

- **Parameter**

None

- **Include**

Peripheral_lib/DrvTIMER.h

- **Return Value**

Capture the results TCR0(0~0xffff)

- **Example**

```
/* Read Capture1 counter */  
unsigned short tcounter; tcounter=DrvCapture1_Read ();
```

4.4.26 DrvCAPTURE2_READ

- **Prototype**

unsigned int DrvCapture2_Read (void)

- **Description**

Read Capture2 counter.

Read the register 0X40C18[31:16]

- **Parameter**

None

- **Include**

Peripheral_lib/DrvTIMER.h

- **Return Value**

Capture2 the results TCR1(0~0xffff)

- **Example**

```
/* Read Capture2 counter */  
unsigned short tcounter; tcounter=DrvCapture2_Read ();
```

4.4.27 DrvCAPTURE_INPUT_PORT

- **Prototype**

unsigned int DrvCapture_lport (uInputPin)

- **Description**

Select the capture input pin.

Configure the register 0X40840[7:5]

- **Parameter**

UInputPin[in]

0 : Port 1.0 =TCI1, Port 1.1 =TCI2, Port 7.1 =TCI3

1 : Port 1.2 =TCI1, Port 1.3 =TCI2, Port 7.3 =TCI3

2 : Port 1.4 =TCI1, Port 1.5 =TCI2, Port 7.5 =TCI3

3 : Port 1.6 =TCI1, Port 1.7 =TCI2, Port 7.7 =TCI3

4 : Port 2.0 =TCI1, Port 2.1 =TCI2, Port 8.1 =TCI3

5 : Port 2.2 =TCI1, Port 2.3 =TCI2, Port 8.3 =TCI3

6 : Port 2.4 =TCI1, Port 2.5 =TCI2, Port 8.5 =TCI3

7 : Port 2.6 =TCI1, Port 2.7 =TCI2, Port 8.7 =TCI3

- **Include**

Peripheral_lib/DrvTIMER.h

- **Return Value**

0: Operation successful

Other : Incorrect argument

- **Example**

```
/* Set capture input pin of Port 1.6=TCI1, Port1.7=TCI2 */
```

```
DrvCapture_Iport (3);
```

4.4.28 DrvTMB_TCI1Edge

- **Prototype**

```
unsigned char DrvTMB_TCI1Edge(unsigned int uedge)
```

- **Description**

Select the TMB TCI1 input mode.

Configure the register 0X40C14[23]

- **Parameter**

uedge [in]

Select the trigger mode of TMB TCI1 input port

0: level trigger

1: rising edge trigger

- **Include**

Peripheral_lib/DrvTIMER.h

- **Return Value**

0: Operation successful

1 : Incorrect argument

- **Example**

```
/* set rising edge trigger mode toTCI1 */
```

```
DrvTMB_CPI1Input (3) : //select TCI1 as input source of CPI1 mode
```

```
DrvTMB_TCI1Edge (1); //set as rising edge trigger for TCI1 IO ;
```

4.4.29 DrvTMB_CPI1Input

- **Prototype**

```
unsigned char DrvTMB_CPI1Input(unsigned int usource)
```

- **Description**

Set the input source in the mode of TMB CPI1 .

Configure the register 0X40C14[21:20]

- **Parameter**

usource [in]

Set the input source in the mode of TMB CPI1

0: CMPO comparator output

1: R2R amplifier output

2:LS_CK

3:IO port

- **Include**

Peripheral_lib/DrvTIMER.h

- **Return Value**

0: Operation successful

1 : Incorrect argument

- **Example**

```
/* Set TCI1 as the input source in the mode of TMB CPI1 */
```

```
DrvTMB_CPI1Input(3);
```

4.4.30 DrvTMB2_Open

- **Prototype**

unsigned int DrvTMB2_Open (E_TMB_MODE eTMBmode, E_TRIGGER_SOURCE eTriSource, eTMBOV)

- **Description**

Enable TMB2 and set TMB2 counter value and TMB2 mode and trigger source. Support compare and capture and counting and timing functions.

Configure the register 0X40C2C[15:0],0X40C24[3:0] / 0X40C24[5]

- **Parameter**

eTMBmode [in]

Specify timer B counting mode.

0: TBR is in UP mode. In the UP mode, the TBR is increase by 1 for every positive edge of TBCLK.

If it is larger than TBC0, TBR changes to 0 for next positive edge of TBCK and TMBIF is change to 1. Then, TBR starts to up count again.

1: TBR is in UP/Down mode. In the UP mode, the TBR is increase by 1 for every positive edge of TBCLK.

If it is equal to TBC0, TBR changes to down mode and TMR become to decrease by 1 for every positive edge of TBCK. Until TBR down count to 0, TMBIF changes to 1 and TBR starts to up count again.

2: TBR is in two 8-bit PWM mode. The TBR is broke to two independent 8-bit UP counters: TBR[15:8]

and TBR[7:0]. The TBR[15:8] up limit is controlled by TBC[15:8] and TBR[7:0] up limit is controlled

by TBC[7:0]. Both of the TBRs are increase by 1 for every positive edge of TBCLK. If TBR[15:8] is equal to TBC0[15:8], then the next positive edge of TBCLK would make TBR[15:8] to be 0. TMBIF still

remains 0. If TBR[7:0] is equal to TBC0[7:0], then the next positive edge of TBCLK would make

TBR[7:0] to be 0. TMBIF changes to 1.

- 3: TBR is in step increment mode. TBR is break into two counters TBR[15:8] and TBR[7:0]. Both of them are in Up mode. However, the limit of TBR[7:0] is controlled by TBC0[7:0]. The TBR[7:0] is increase by 1 for every positive edge of TBCLK. If TBR[7:0] is equal to TBC0[7:0], then it would change to 0 at next positive edge of TBCLK. Moreover, the TMBIF changes to 1 and TBR[15:8] increases by 1.

eTriSource [in]

Specify TMB2 trigger source.

0: Always Enable

1: CMP high trigger

2: OP high trigger

3:TMC output high trigger (CPI1)

eTMAOV [in]

Specify overflow condition. (0~0xffff)

- **Include**

Peripheral_lib/DrvTIMER.h

- **Return Value**

0: Operation successful

Other : Incorrect argument

- **Example**

```
/* Enable timerB2 mode1 and set counter value is tack/32 and trigger form OP. */
```

```
DrvTMB2_Open (E_TMB_MODE0, E_TMB_OP_HIGH,4);
```

4.4.31 DrvTMB2_Close

- **Prototype**

```
void DrvTMB2_Close (void)
```

- **Description**

Close timer B2

Configure the register 0x40C24[5]=0

- **Parameter**

None

- **Include**

Peripheral_lib/DrvTIMER.h

- **Return Value**

None

- **Example**

```
/* Disable timerB2 */
```

```
DrvTMB2_Close ();
```

4.4.32 DrvTMB2_CLK_SOURCE

- **Prototype**

unsigned int DrvTMB2_Clk_Source (E_DRVTIMER_CLOCK_SOURCE uclk, uPerScale)

- **Description**

Timer B2 clock source selection and clock divider selection.

Configure the register 0x40314[7:4]

- **Parameter**

uclk[in]

Specify timer B2 clock source.

0: HS_CLK

1: LS_CLK

uPerScale [in]

Specify timer B2 clock divider.

0: ÷1

1: ÷2

2: ÷4

3: ÷8

- **Include**

Peripheral_lib/DrvTIMER.h

- **Return Value**

0: Operation successful

Other : Incorrect argument

- **Example**

```
/* Select the timer B2 clock from HS_CLK, divider of 2. */
```

```
DrvTMB2_Clk_Source (0,1);
```

4.4.33 DrvTMB2_CLK_DISABLE

- **Prototype**

viod DrvTMB2_Clk_Disable (viod)

- **Description**

Disable timer B2 clock.

Configure the register 0x40314[6]=0

- **Parameter**

None

- **Include**

Peripheral_lib/DrvTIMER.h

- **Return Value**

None

- **Example**

```
/* Disable timer B2 clock.*/  
DrvTMB2_Clk_Disable ();
```

4.4.34 DrvTMB2_CLEAR_TMB

- **Prototype**

void DrvTMB2_ClearTMB (void)

- **Description**

Clear the counting register of Timer B2.

Configure the register 0x40C24[4]=1, and automatically change to 0 after clear.

- **Parameter**

None

- **Include**

Peripheral_lib/DrvTIMER.h

- **Return Value**

None

- **Example**

```
/* Clear Timer B2 counter */  
DrvTMB2_ClearTMB();
```

4.4.35 DrvTMB2_COUNTER_READ

- **Prototype**

unsigned int DrvTMB2_CounterRead (void)

- **Description**

Read the current TMB2 counter.

Read the register 0x40C28[15:0]

- **Parameter**

None

- **Include**

Peripheral_lib/DrvTIMER.h

- **Return Value**

The return values of TMB2 counter.

- **Example**

```
/* Read the current TMB2 counter */
```

```
unsigned short tcounter; tcounter=DrvTMB2_CounterRead ();
```

4.4.36 DrvPWM2_Open

- **Prototype**

```
unsigned int DrvPWM2_Open (uPWM_Mode , uInv, uOutputPin)
```

- **Description**

Enable PWM2 and PWM2 operation mode selection. Select IO port to output. PWM2 output inverse control
Configure the register 0X40C24[18:16] / 0X40C24[19], 0X40848[4:2] / 0X40848[0]

- **Parameter**

uPWM_Mode [in]

PWM2 Operation mode selection

0: PWM A 1: PWM B

2: PWM C 3: PWM D

4 : PWM E 5 : PWM F

6 : PWM G 7 : PWM G

uInv[in]

PWM2 output inverse control.

0 : inverse

1 : Normal

uOutputPin[in]

0 : Port 1.2 =PWMO2, Port 1.3 =PWMO3

1 : Port 1.6 =PWMO2, Port 1.7 =PWMO3

2 : Port 2.2 =PWMO2, Port 2.3 =PWMO3

3 : Port 2.6 =PWMO2, Port 2.7 =PWMO3

4 : Port 8.2 =PWMO2, Port 8.3 =PWMO3

5 : Port 8.6 =PWMO2, Port 8.7 =PWMO3

6 : Port 9.2 =PWMO2, Port 9.3 =PWMO3

7 : Port 9.6 =PWMO2, Port 9.7 =PWMO3

- **Include**

Peripheral_lib/DrvTIMER.h

- **Return Value**

0: Operation successful

Other : Incorrect argument

- **Example**

```
/* Enable PWM2, PWM2 working in PWMA mode, the reverse signal. */  
DrvPWM0_Open (0, 0, 0);
```

4.4.37 DrvPWM3_Open

- **Prototype**

unsigned int DrvPWM3_Open (uPWM_Mode , ulnv, uOutputPin)

- **Description**

Enable PWM3 and PWM3 operation mode selection. Select IO port to output. PWM output inverse control
Configure the register 0X40C24[23:20],0X40848[4:1]

- **Parameter**

uPWM_Mode [in]

PWM3 Operation mode selection

0: PWM A 1: PWM B

2: PWM C 3: PWM D

4 : PWM E 5 : PWM F

6 : PWM G 7 : PWM G

ulnv[in]

PWM3 output inverse control.

0 : inverse

1 : Normal

uOutputPin[in]

0 : Port 1.2 =PWMO2, Port 1.3 =PWMO3

1 : Port 1.6 =PWMO2, Port 1.7 =PWMO3

2 : Port 2.2 =PWMO2, Port 2.3 =PWMO3

3 : Port 2.6 =PWMO2, Port 2.7 =PWMO3

4 : Port 8.2 =PWMO2, Port 8.3 =PWMO3

5 : Port 8.6 =PWMO2, Port 8.7 =PWMO3

6 : Port 9.2 =PWMO2, Port 9.3 =PWMO3

7 : Port 9.6 =PWMO2, Port 9.7 =PWMO3

- **Include**

Peripheral_lib/DrvTIMER.h

- **Return Value**

0: Operation successful

Other : Incorrect argument

- **Example**

```
/* Enable PWM3, PWM3 working in PWMA mode, the reverse signal. */
```

```
DrvPWM3_Open (0, 0, 0);
```

4.4.38 DrvTMB2PWM_COUNT_CONDITION

- **Prototype**

```
void DrvTMB2PWM_CountCondition (uTBC2, uTBC1)
```

- **Description**

PWM2/PWM3 count condition parameter (TBC2, TBC1) setting.

Configure the register 0X40C30[15:0](TBC1) / 0X40C30[15:0](TBC2)

- **Parameter**

uTBC1 [in]

Specify the TBC1 Condition. (0~65535)

uTBC2 [in]

Specify the TBC2 Condition. (0~65535)

- **Include**

Peripheral_lib/DrvTIMER.h

- **Return Value**

None

- **Example**

```
/* Set TBC1, TBC2 value of 0x4000 */
```

```
DrvTMB2PWM_CountCondition (0x4000,0x4000);
```

4.4.39 DrvPWM2_Close

- **Prototype**

```
void DrvPWM2_Close (void)
```

- **Description**

PWM2 off

Configure the register 0x40848[0]

- **Parameter**

None

- **Include**

Peripheral_lib/DrvTIMER.h

- **Return Value**

None

- **Example**

```
/*PWM2 off */
```

```
DrvPWM2_Close ();
```

4.4.40 DrvPWM3_Close

- **Prototype**

```
void DrvPWM3_Close (void)
```

- **Description**

PWM3 off
Configure the register 0x40848[1]

- **Parameter**

None

- **Include**

Peripheral_lib/DrvTIMER.h

- **Return Value**

None

- **Example**

```
/*PWM3 off */  
DrvPWM3_Close ();
```

4.4.41 DrvTMB2_CPI3Input

- **Prototype**

unsigned char DrvTMB2_CPI3Input(unsigned int usource)

- **Description**

Set the input source in the mode of TMB2 CPI3 .
Configure the register 0X40C34[21:20]

- **Parameter**

usource [in]

Set the input source in the mode of TMB2 CPI3

0: CMPO comparator output

1: R2R amplifier output

2:LS_CK

3:IO port

- **Include**

Peripheral_lib/DrvTIMER.h

- **Return Value**

0: Operation successful

1 : Incorrect argument

- **Example**

```
/* Set TCI3 as the input source in the mode of TMB2 CPI3 */  
DrvTMB2_CPI3Input(3);
```

4.4.42 DrvTMB2_TCI3Edge

- **Prototype**

unsigned char DrvTMB2_TCI3Edge(unsigned int uedge)

- **Description**

Select the trigger method of TMB2 TCI3 input source.

Configure the register 0X40C34[23]

- **Parameter**

uedge [in]

Select the TMB2 TCI3 input mode

0: level trigger

1: rising edge trigger

- **Include**

Peripheral_lib/DrvTIMER.h

- **Return Value**

0: Operation successful

1 : Incorrect argument

- **Example**

```
/* set rising edge trigger mode toTCI1 */
```

```
DrvTMB2_CPI3Input (3) ; //select TCI1 as input source of CPI3 mode
```

```
DrvTMB2_TCI3Edge (1); //set as rising edge trigger for TCI3 IO ;
```

5. GPIO Driver

5.1 Introduction

The following functions are included in GPIO Manager Section.

Item	Functions	Description
01	DrvGPIO_Open	Set the GPIO operation mode
02	DrvGPIO_SetBit	Set the specified GPIO pin to 1
03	DrvGPIO_ClrBit	Set the specified GPIO pin to 0.
04	DrvGPIO_GetBit	Get the pin value
05	DrvGPIO_SetPortBits	Set the output port value
06	DrvGPIO_ClrPortBits	Clear the output port value
07	DrvGPIO_GetPortBits	Get the input port value
08	DrvGPIO_IntTrigger	Set the specified interrupt pin mode
09	DrvGPIO_CLK_GENERATOR	Set IO sampling clock input source
10	DrvGPIO_CLEAR_INT_FLAG	Clear external interrupt flag
11	DrvGPIO_GetIntFlag	Get the interrupt flag
12	DrvGPIO_Close	Close the GPIO operation mode
13	DrvGPIO_LCDIOOpen	Set the GPIO(PT6~10) operation mode
14	DrvGPIO_LCDIOClose	Close the GPIO(PT6~10) operation mode
15	DrvGPIO_LCDIOSetPorts	Set the specified GPIO(PT6~10) pin to 1
16	DrvGPIO_LCDIOClrPorts	Set the specified GPIO(PT6~10) pin to 0.
17	DrvGPIO_LCDIOSetBit	Set one specified GPIO(PT6~10) pin to 1
18	DrvGPIO_LCDIOClrBit	Set one specified GPIO(PT6~10) pin to 0.
19	DrvGPIO_LCDIOGetPorts	Get the input port value from the GPIO(PT6~PT10) port
20	DrvGPIO_LCDIOGetBit	Get one input port value from the GPIO(PT6~PT10) port
21	DrvGPIO_EnableAnalogPin	Disabled the GPIO digital mode.Enable the GPIO analog mode
22	DrvGPIO_PT1_EnableINPUT	Enable the input mode for specified pin of PT1
23	DrvGPIO_PT1_DisableINPUT	Disable the input mode for specified pin of PT1
24	DrvGPIO_PT1_EnablePullHigh	Enable the pull up mode for specified pin of PT1
25	DrvGPIO_PT1_DisablePullHigh	Disable the pull up mode for specified pin of PT1
26	DrvGPIO_PT1_EnableOUTPUT	Enable the output mode for specified pin of PT1
27	DrvGPIO_PT1_DisableOUTPUT	Disable the output mode for specified pin of PT1
28	DrvGPIO_PT1_EnableINT	Enable the external interrupt for the specified pin of PT1
29	DrvGPIO_PT1_DisableINT	Disable the external interrupt for the specified pin of PT1
30	DrvGPIO_PT1_IntTriggerPorts	Configure the external interrupt trigger method for PT1
31	DrvGPIO_PT1_IntTriggerBit	Configure the external interrupt trigger method for the specified pin of PT1
32	DrvGPIO_PT1_ClearIntFlag	Clear the interrupt flag of the specified pin
33	DrvGPIO_PT1_GetIntFlag	Get the interrupt flag of the specified pin
34	DrvGPIO_PT1_GetPortBits	Get the input port value from the specified pin
35	DrvGPIO_PT1_SetPortBits	Set the output port value of the specified pin
36	DrvGPIO_PT1_ClrPortBits	Clear the output port value of the specified pin
37	DrvGPIO_PT2_EnableINPUT	Enable the input mode of the specified pin
38	DrvGPIO_PT2_DisableINPUT	Disable the input mode of the specified pin
39	DrvGPIO_PT2_EnablePullHigh	Enable the pull up of the specified pin
40	DrvGPIO_PT2_DisablePullHigh	Disable the pull up of the specified pin
41	DrvGPIO_PT2_EnableOUTPUT	Enable the output mode of the specified pin
42	DrvGPIO_PT2_DisableOUTPUT	Disable the output mode of the specified pin

43	DrvGPIO_PT2_EnableINT	Enable the external interrupt function of the specified pin
44	DrvGPIO_PT2_DisableINT	Disable the external interrupt function of the specified pin
45	DrvGPIO_PT2_IntTriggerPorts	Configure the external interrupt trigger method for PT2
46	DrvGPIO_PT2_IntTriggerBit	Configure the external interrupt trigger method for the specified pin of PT2
47	DrvGPIO_PT2_ClearIntFlag	Clear the interrupt flag of the specified pin
48	DrvGPIO_PT2_GetIntFlag	Get the interrupt flag of the specified pin
49	DrvGPIO_PT2_GetPortBits	Get the input port value from the specified pin
50	DrvGPIO_PT2_SetPortBits	Set the output port value of the specified pin
51	DrvGPIO_PT2_ClrPortBits	Clear the output port value of the specified pin
52	DrvGPIO_PT3_EnableINPUT	Enable the input mode of the specified pin
53	DrvGPIO_PT3_DisableINPUT	Disable the input mode of the specified pin
54	DrvGPIO_PT3_EnablePullHigh	Enable the pull up of the specified pin
55	DrvGPIO_PT3_DisablePullHigh	Disable the pull up of the specified pin
56	DrvGPIO_PT3_EnableOUTPUT	Enable the output mode of the specified pin
57	DrvGPIO_PT3_DisableOUTPUT	Disable the output mode of the specified pin
58	DrvGPIO_PT3_GetPortBits	Get the input port value from the specified pin
59	DrvGPIO_PT3_SetPortBits	Set the output port value of the specified pin
60	DrvGPIO_PT3_ClrPortBits	Clear the output port value of the specified pin
61	DrvGPIO_PT6_EnableINPUT□	Enable the input mode of the specified pin
62	DrvGPIO_PT6_DisableINPUT□	Disable the input mode of the specified pin
63	DrvGPIO_PT6_EnableOUTPUT□	Enable the output mode of the specified pin
64	DrvGPIO_PT6_DisableOUTPUT□	Disable the output mode of the specified pin
65	DrvGPIO_PT6_GetPortBits□	Get the input port value from the specified pin
66	DrvGPIO_PT6_SetPortBits□	Set the output port value of the specified pin
67	DrvGPIO_PT6_ClrPortBits□	Clear the output port value of the specified pin
68	DrvGPIO_PT7_EnableINPUT□	Enable the input mode of the specified pin
69	DrvGPIO_PT7_DisableINPUT□	Disable the input mode of the specified pin
70	DrvGPIO_PT7_EnableOUTPUT□	Enable the output mode of the specified pin
71	DrvGPIO_PT7_DisableOUTPUT□	Disable the output mode of the specified pin
72	DrvGPIO_PT7_GetPortBits□	Get the input port value from the specified pin
73	DrvGPIO_PT7_SetPortBits□	Set the output port value of the specified pin
74	DrvGPIO_PT7_ClrPortBits□	Clear the output port value of the specified pin
75	DrvGPIO_PT8_EnableINPUT□	Enable the input mode of the specified pin
76	DrvGPIO_PT8_DisableINPUT□	Disable the input mode of the specified pin
77	DrvGPIO_PT8_EnableOUTPUT□	Enable the output mode of the specified pin
78	DrvGPIO_PT8_DisableOUTPUT□	Disable the output mode of the specified pin
79	DrvGPIO_PT8_GetPortBits□	Get the input port value from the specified pin
80	DrvGPIO_PT8_SetPortBits□	Set the output port value of the specified pin
81	DrvGPIO_PT8_ClrPortBits□	Clear the output port value of the specified pin
82	DrvGPIO_PT9_EnableINPUT□	Enable the input mode of the specified pin
83	DrvGPIO_PT9_DisableINPUT□	Disable the input mode of the specified pin
84	DrvGPIO_PT9_EnableOUTPUT□	Enable the output mode of the specified pin
85	DrvGPIO_PT9_DisableOUTPUT□	Disable the output mode of the specified pin
86	DrvGPIO_PT9_GetPortBits□	Get the input port value from the specified pin
87	DrvGPIO_PT9_SetPortBits□	Set the output port value of the specified pin
88	DrvGPIO_PT9_ClrPortBits□	Clear the output port value of the specified pin
89	DrvGPIO_PT10_EnableINPUT□	Enable the input mode of the specified pin
90	DrvGPIO_PT10_DisableINPUT□	Disable the input mode of the specified pin
91	DrvGPIO_PT10_EnableOUTPUT	Enable the output mode of the specified pin
92	DrvGPIO_PT10_DisableOUTPUT	Disable the output mode of the specified pin
93	DrvGPIO_PT10_GetPortBits□	Get the input port value from the specified pin
94	DrvGPIO_PT10_SetPortBits□	Set the output port value of the specified pin
95	DrvGPIO_PT10_ClrPortBits□	Clear the output port value of the specified pin
96	DrvGPIO_PortIDIF□	Read thePT1/PT2 condition flag of interrupt trigger

5.2 The block diagram of GPIO

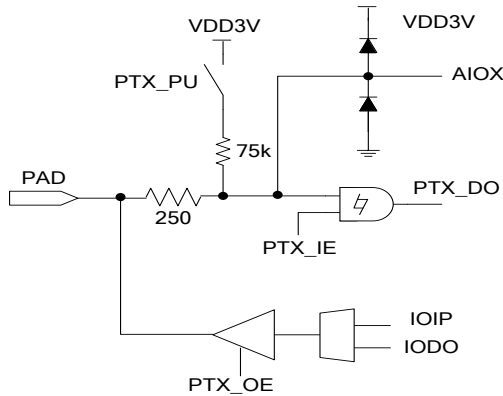

5.3 Type Definition

E_DRVGPIO_PORT

Enumeration Identifier	Value	Description
E_PT0	0	Define GPIO Port 0
E_PT1	1	Define GPIO Port 1
E_PT2	2	Define GPIO Port 2
E_PT3	3	Define GPIO Port 3
E_PT6	0	Define GPIO Port 6
E_PT7	1	Define GPIO Port 7
E_PT8	2	Define GPIO Port 8
E_PT9	3	Define GPIO Port 9
E_PT10	4	Define GPIO Port 10
E_COM54	5	Define Port COM5/COM4

E_DRVGPIO_IO

Enumeration Identifier	Value	Description
E_IO_INPIT	0	Set GPIO as Input mode
E_IO_OUTPUT	1	Set GPIO as Output mode
E_IO_PullHigh	2	Pull High Enable
E_IO_IntEnable	3	Interrupt Enable

E_DRVGPIO_IntTriMethod

Enumeration Identifier	Value	Description
E_DisableGPIOInt	0	Disable GPIO Interrupt
E_P_Edge	1	Positive Edge
E_N_Edge	2	Negative Edge
E_Chang_Level	3	Chang Level
E_LLTri	4	Level Low Trigger
E_LHTri	5	Level High Trigger
E_LLTri	6	Level Low Trigger
E_LHTri	7	Level High Trigger

E_DRVGPIO_CLOCK_SOURCE

Enumeration Identifier	Value	Description
E_HS_CK	0	Set IO sampling clock input source is HS_CK
E_LS_CK	1	Set IO sampling clock input source is LS_CK

5.4 Functions

5.4.1 DrvGPIO_Open

- **Prototype**

int32_t DrvGPIO_Open (E_DRVGPIO_PORT port, int32_t i32Bit, E_DRVGPIO_IO mode)

- **Description**

Set the specified GPIO(PT1~PT3) pin to the specified GPIO operation mode.

Configure the register PT1 0X40800[23:16] / 0X40800[7:0] / 0X40804[23:16] / 0X40010[23:16]

PT2 0X40810[23:16] / 0X40810[7:0] / 0X40814[23:16] / 0X40014[23:16]

PT3 0X40820[23:16] / 0X40820[7:0] / 0X40824[23:16]

- **Parameter**

port [in] specify GPIO port.

1: PT1 2: PT2

3: PT3 4: RSV

i32Bit [in] Specify pin of the GPIO port. It could be 0~0xFF.

The operation mode of the pin will be set if the bit of i32Bit is equal to 1

The operation mode of the pin will not be change if the bit of i32Bit is equal to 0

mode [in] set the operation mode of the specified GPIO pin

0: Enable input mode 1: Enable output mode

2: Enable pull up internally 3:Enable external interrupt

- **Include**

Peripheral_lib/DrvGPIO.h

- **Return Value**

0: Operation successful

Other : Incorrect argument

- **Example**

/* configure PT1.0 to GPIO output mode and PT1.0 to GPIO input mode*/

DrvGPIO_Open (E_PT1, 0x01, E_IO_OUTPUT); //set the operation mode of PT1.0

DrvGPIO_Open (E_PT1, 0x02, E_IO_INPUT); //set the operation mode of PT1.1

5.4.2 DrvGPIO_SetBit

- **Prototype**

unsigned int DrvGPIO_SetBit (E_DRVGPIOPORT uport, unsigned int i32Bit)

- **Description**

Set the output status value of the specified GPIO(PT1~PT3) pad to 1.

Configure the register 0x40804[7:0]/0x40814[7:0]/0x40824[7:0]

- **Parameter**

uport [in] specify GPIO port. It could be 1~4.

1: PT1 2: PT2

3: PT3 4: RSV

i32Bit [in]

Specify pin of the GPIO port. It could be 0~7.

- **Include**

Peripheral_lib/DrvGPIO.h

- **Return Value**

0: Operation successful

Other : Incorrect argument

- **Example**

```
/* configure PT1-0 as GPIO output mode*/  
DrvGPIO_Open (E_PT1, 0, E_IO_OUTPUT);  
/* Set PT1-0 to 1(high) */  
DrvGPIO_SetBit (E_PT1, 0);
```

5.4.3 DrvGPIO_ClrBit

- **Prototype**

unsigned int DrvGPIO_ClrBit (E_DRVGPIOPORT uport, unsigned int i32Bit)

- **Description**

Clear the output status value of the specified GPIO(PT1~PT3) pad.

Clear the register 0x40804[7:0]/0x40814[7:0]/0x40824[7:0]

- **Parameter**

uport [in] specify GPIO port. It could be 1~4.

1: PT1 2: PT2

3: PT3 4: RSV

i32Bit [in]

Specify pin of the GPIO port. It could be 0~7.

- **Include**

Peripheral_lib/DrvGPIO.h

- **Return Value**

0: Operation successful
0xff000000 : Incorrect argument

- **Example**

```
/* Set PT1-0 output 0(low) */  
DrvGPIO_ClrBit (E_PT1, 0);
```

5.4.4 DrvGPIO_GetBit

- **Prototype**

uint8_t DrvGPIO_GetBit (E_DRVGPIOPORT port, uint8_t u32Bit)

- **Description**

Get the pin value from the specified input GPIO(PT1~PT3) pin.
Read the register 0x40808[7:0]/0x40818[7:0]/0x40828[7:0]

- **Parameter**

port [in]
uport [in] specify GPIO port. It could be 1~4.
1: PT1 2: PT2
3: PT3 4: RSV
i32Bit [in]
Specify pin of the GPIO port. It could be 0~7.

- **Include**

Peripheral_lib/DrvGPIO.h

- **Return Value**

0 / 1: The specified input pin value:
0xff000000 : Incorrect argument,

- **Example**

```
uint32_t i32BitValue;  
/* Configure PT1-1 as GPIO input mode, and read the input value of status*/  
DrvGPIO_Mode (E_PT1, 1, E_IO_INPUT);  
i32BitValue = DrvGPIO_GetBit (E_PT1, 1);  
if (u32BitValue == 1)  
{  
    printf("PT1-1 pin status is high.\n");  
}  
else  
{  
    printf("PT1-1 pin status is low.\n");  
}
```

5.4.5 DrvGPIO_SetPortBits

- **Prototype**

unsigned int DrvGPIO_SetPortBits (E_DRVGPIOPORT uport, unsigned int ui32Data)

- **Description**

Set the output port value to the specified GPIO(PT1~PT3) port.

Configure the register 0x40804[7:0]/0x40814[7:0]/0x40824[7:0]

- **Parameter**

uport [in] specify GPIO port. It could be 1~4.

1: PT1 2: PT2

3: PT3 4: RSV

i32Data [in] specify which bit to be set.

The bit will be set 1 if the bit of the i32Data is equal to 1

- **Include**

Peripheral_lib/DrvGPIO.h

- **Return Value**

0: Operation successful

Other : Incorrect argument

- **Example**

```
/* Set PT1.2 PT1.4 */
```

```
DrvGPIO_SetPortBits (E_PT1, 0x12);
```

5.4.6 DrvGPIO_ClrPortBits

- **Prototype**

unsigned int DrvGPIO_ClrPortBits (E_DRVGPIOPORT uport, unsigned int ui32Data)

- **Description**

Clear the output port value to the specified GPIO(PT1~PT3) port

Clear the register 0x40804[7:0]/0x40814[7:0]/0x40824[7:0]

- **Parameter**

uport [in] specify GPIO port. It could be 1~4.

1: PT1 2: PT2

3: PT3 4: RSV

i32Data [in] specify which bit to be set.

The bit will change to 0 if the bit of i32Data is equal to 1

- **Include**

Peripheral_lib/DrvGPIO.h

- **Return Value**

0: Operation successful
Other : Incorrect argument

- **Example**

```
/* Clear the output value of PT1.1/PT1.4 */  
DrvGPIO_ClrPortBits (E_PT1, 0x12);
```

5.4.7 DrvGPIO_GetPortBits

- **Prototype**

uint32_t DrvGPIO_GetPortBits (E_DRVGPIO_PORT port)

- **Description**

Get the input port value from the specified GPIO(PT1~PT3) port.
Read the register 0x40808[7:0]/0x40818[7:0]/0x40828[7:0]

- **Parameter**

port [in] specify GPIO port. It could be 1~4.
1: PT1 2: PT2
3: PT3 4: RSV

- **Include**

Peripheral_lib/DrvGPIO.h

- **Return Value**

0 ~ 0xFF :The specified input port value
0xff000000: Incorrect argument ,

- **Example**

```
/* Get the PT1 port input data value */  
uint32_t i32Port; i32Port = DrvGPIO_GetPortBits (E_PT1);
```

5.4.8 DrvGPIO_IntTrigger

- **Prototype**

int32_t DrvGPIO_IntTrigger (E_DRVGPIO_PORT port, uint32_t u32Bit, E_DRVGPIO_TriMethod mode)

- **Description**

Set the specified interrupt pin to the specified interrupt trigger method operation mode.
Configure the register 0 x4080C[31:0]/0x4081C[31:0]

- **Parameter**

port [in] Specify GPIO port
1: PT1 2: PT2

u32Bit [in] Specify pin of the GPIO port.

The bit will be set if the bit of the u32Bit is equal to 1. It could be 0~255.

mode [in] set the specified interrupt method

0: disable the IO external interrupt trigger 1: positive edge trigger

2: negative edge trigger 3: level change trigger

4: level low trigger 5: level high trigger

6: level low trigger 7: level high trigger

● Include

Peripheral_lib/DrvGPIO.h

● Return Value

0: Operation successful

Other : Incorrect argument

● Example

```
/* Configure PT1-0 to GPIO Interrupt mode ,trigger method is negative edge*/  
DrvGPIO_ClkGenerator (0,1); //set IO sample frequency  
DrvGPIO_Open (E_PT1, 1, E_IO_ IntEnable); //enable PT1.0 external interrupt  
DrvGPIO_IntTrigger (E_PT1, 1, E_N_Edge); //set PT1.0 interrupt trigger method
```

5.4.9 DrvGPIO_CLK_GENERATOR

● Prototype

```
uint32_t DrvGPIO_ClkGenerator ( E_DRVGPIO_CLK_SOURCE uClk, uint32_t uDivider)
```

● Description

Set IO sampling clock input source and divider.

Configure the register 0x4030C[20:16]

● Parameter

uClk [in] specify GPIO sampling clock source

0 : (HS_CK)

1 : (LS_CK)

uDivider [in]

Specify I/O Port sampling clock source divider. It could be 0~15.

0: off 1: ÷1

2: ÷2 3: ÷4

4: ÷8 5: ÷16

6: ÷32 7: ÷64

8: ÷128 9: ÷256

10: ÷512 11: ÷1024

12: ÷2048 13: ÷4096

14: ÷8192 15: ÷16384

- **Include**

Peripheral_lib/DrvGPIO.h

- **Return Value**

0: Operation successful
Other : Incorrect argument

- **Example**

```
/* Specify I/O Port sampling clock source is HS_CK and clk/2 .*/  
DrvGPIO_ClkGenerator (E_HS_CK, 2);
```

5.4.10 DrvGPIO_CLEAR_INT_FLAG

- **Prototype**

Unsigned int DrvGPIO_ClearIntFlag (E_DRVGPIOPORT port, uint32_t u32Bit)

- **Description**

Clear external interrupt flag.
Clear the register 0X40010[7 :0] / 0X40014[7 :0]

- **Parameter**

port [in] Specify GPIO port

1: PT1 2: PT2

u32Bit [in] Specify pin of the GPIO port. It could be 0~0xFF

The corresponding bit of register will be clear if the bit of the u32Bit is equal to 1.

- **include**

Peripheral_lib/DrvGPIO.h

- **Return Value**

The current state of GPIO external interrupt 4flags

- **Example**

```
/* Clear PT1.2 interrupt flag */  
DrvGPIO_ClearIntFlag (E_PT1, 0x04);  
/*clearPT1.3 interrupt flag*/  
DrvGPIO_ClearIntFlag(E_PT1,0x08);
```

5.4.11 DrvGPIO_GET_IntFlag

- **Prototype**

unsigned int DrvGPIO_GetIntFlag(E_DRVGPIOPORT port)

- **Description**

Get the port value from the specified Interrupt Trigger Source Indicator Register. If the corresponding bit of the return port value is 1, it is meaning the interrupt occurred at the corresponding bit. Otherwise, no interrupt occurred at that bit.

Read the register 0X40010[7 :0] / 0X40014[7 :0]

- **Parameter**

port [in] Specify GPIO port

1: PT1 2: PT2

- **Include**

Peripheral_lib/DrvGPIO.h

- **Return Value**

The port value of the specified register: 0 ~ 0Xff

- **Example**

```
/* Get PT1 interrupt status. */  
unsigned char flag; flag=DrvGPIO_GetIntFlag (E_PT1);
```

5.4.12 DrvGPIO_Close

- **Prototype**

int32_t DrvGPIO_Close (E_DRVGPIO_PORT port, int32_t i32Bit, E_DRVGPIO_IO mode)

- **Description**

Close the specified operation mode of the specified GPIO pin

Configure the register PT1 0X40800[23:16] / 0X40800[7:0] / 0X40804[23:16] / 0X40010[23:16]

PT2 0X40810[23:16] / 0X40810[7:0] / 0X40814[23:16] / 0X40014[23:16]

PT3 0X40820[23:16] / 0X40820[7:0] / 0X40824[23:16]

- **Parameter**

port [in] Specify GPIO port.

1: PT1 2: PT2

3: PT3 4: RSV

i32Bit [in] Specify pin of the GPIO port. It could be 0~0xFF.

The operation mode of the pin will be close if the bit of i32Bit is equal to 1

The operation mode of the pin will not be change if the bit of i32Bit is equal to 0

mode [in] set the operation mode of the specified GPIO pin

0: input mode 1: output mode

2: pull up internally 3: external interrupt

- **Include**

Peripheral_lib/DrvGPIO.h

- **Return Value**

0: Operation successful

Other : Incorrect argument

- **Example**

```
DrvGPIO_Close (E_PT1, 0x01, E_IO_OUTPUT); //close the specified operation mode of PT1.0
```

```
DrvGPIO_Close (E_PT1, 0x02, E_IO_INPUT); //close the specified operation mode of PT1.1
```

5.4.13 DrvGPIO_LCDIOOpen

- **Prototype**

unsigned char DrvGPIO_LCDIOOpen (E_DRVGPIO_PORT port, int32_t i32Bit, E_DRVGPIO_IO mode)

- **Description**

Set the specified GPIO(PT6~PT10) pin to the specified GPIO operation mode(input or output).

Configure the register PT6 0X40850[19:18][3:2]/ 0X40854[19:18][3:2]/ 0X40858[19:18][3:2] / 0X4085C[19:18][3:2]

PT7 0X40860[19:18][3:2]/ 0X40864[19:18][3:2]/ 0X40868[19:18][3:2] / 0X4086C[19:18][3:2]

PT8 0X40870[19:18][3:2]/ 0X40874[19:18][3:2]/ 0X40878[19:18][3:2] / 0X4087C[19:18][3:2]

PT9 0X40880[19:18][3:2]/ 0X40884[19:18][3:2]/ 0X40888[19:18][3:2] / 0X4088C[19:18][3:2]

PT10 0X40890[19:18][3:2]

- **Parameter**

port [in] specify GPIO port.

0: PT6 1: PT7 2: PT8

3: PT9 4: PT10

i32Bit [in] Specify pin of the GPIO port. It could be 0~0xFF.

The operation mode of the pin will be set if the bit of i32Bit is equal to 1

The operation mode of the pin will not be change if the bit of i32Bit is equal to 0

mode [in] Set the operation mode of the specified GPIO pin

0: Enable input mode

1: Enable output mode

- **Include**

Peripheral_lib/DrvGPIO.h

- **Return Value**

0: Operation successful

Other : Incorrect argument

- **Example**

```
/* configure PT6.0 to GPIO output mode and PT6.1 to GPIO input mode*/
```

```
DrvGPIO_LCDIOOpen (E_PT6, 0x01, E_IO_OUTPUT); //set the operation mode of PT6.0
```

```
DrvGPIO_LCDIOOpen (E_PT6, 0x02, E_IO_INPUT); //set the operation mode of PT6.1
```

5.4.14 DrvGPIO_LCDIOClose

- **Prototype**

unsigned char DrvGPIO_LCDIOClose (E_DRVGPIO_PORT port, int32_t i32Bit, E_DRVGPIO_IO mode)

- **Description**

Disable the specified GPIO operation mode(input or output) of the specified GPIO(PT6~PT10) pin.

Configure the register PT6 0X40850[19:18][3:2]/ 0X40854[19:18][3:2]/ 0X40858[19:18][3:2] / 0X4085C[19:18][3:2]

PT7 0X40860[19:18][3:2]/ 0X40864[19:18][3:2]/ 0X40868[19:18][3:2] / 0X4086C[19:18][3:2]

PT8 0X40870[19:18][3:2]/ 0X40874[19:18][3:2]/ 0X40878[19:18][3:2] / 0X4087C[19:18][3:2]

PT9 0X40880[19:18][3:2]/ 0X40884[19:18][3:2]/ 0X40888[19:18][3:2] / 0X4088C[19:18][3:2]

PT10 0X40890[19:18][3:2]

● Parameter

port [in] specify GPIO port.

0: PT6 1: PT7 2: PT8

3: PT9 4: PT10

i32Bit [in] Specify pin of the GPIO port. It could be 0~0xFF.

The operation mode of the pin will be set if the bit of i32Bit is equal to 1

The operation mode of the pin will not be change if the bit of i32Bit is equal to 0

mode [in] Set the operation mode of the specified GPIO pin

0: Enable input mode

1: Enable output mode

● Include

Peripheral_lib/DrvGPIO.h

● Return Value

0: Operation successful

Other : Incorrect argument

● Example

```
DrvGPIO_LCDIOClose (E_PT6, 0x01, E_IO_OUTPUT); //close the operation mode of PT6.0
```

```
DrvGPIO_LCDIOClose (E_PT6, 0x02, E_IO_INPUT); //close the operation mode of PT6.1
```

5.4.15 DrvGPIO_ LCDSetPorts

● Prototype

```
unsigned char DrvGPIO_LCDIOSetPorts (E_DRVGPIOPORT uport, unsigned int ui32Data)
```

● Description

Set the output status value of the specified GPIO(PT6~PT10) to 1

Configure the register PT6 0X40850[17][1]/ 0X40854[17][1]/ 0X40858[17][1] / 0X4085C[17][1]

PT7 0X40860[17][1]/ 0X40864[17][1]/ 0X40868[17][1] / 0X4086C[17][1]

PT8 0X40870[17][1]/ 0X40874[17][1]/ 0X40878[17][1] / 0X4087C[17][1]

PT9 0X40880[17][1]/ 0X40884[17][1]/ 0X40888[17][1] / 0X4088C[17][1]

PT10 0X40890[17][1]

● Parameter

port [in] Specify GPIO port.

0: PT6 1: PT7 2: PT8
3: PT9 4: PT10

ui32Data [in] The specified pin of the GPIO port. It could be 0~0xFF.

The operation mode of the pin will be set if the bit of i32Bit is equal to 1

The operation mode of the pin will not be change if the bit of i32Bit is equal to 0

- **Include**

Peripheral_lib/DrvGPIO.h

- **Return Value**

0: Operation successful

Other : Incorrect argument

- **Example**

```
/* configure PT6.1 and PT6.4 */
```

```
DrvGPIO_LCDIOSetPorts (E_PT6, 0x12);
```

5.4.16 DrvGPIO_ LCDClrPorts

- **Prototype**

unsigned char DrvGPIO_LCDClrPorts (E_DRVGPIO_PORT uport, unsigned int ui32Data)

- **Description**

Set the output status value of the specified GPIO(PT6~PT10) to 0

Configure the register PT6 0X40850[17][1]/ 0X40854[17][1]/ 0X40858[17][1] / 0X4085C[17][1]

PT7 0X40860[17][1]/ 0X40864[17][1]/ 0X40868[17][1] / 0X4086C[17][1]

PT8 0X40870[17][1]/ 0X40874[17][1]/ 0X40878[17][1] / 0X4087C[17][1]

PT9 0X40880[17][1]/ 0X40884[17][1]/ 0X40888[17][1] / 0X4088C[17][1]

PT10 0X40890[17][1]

- **Parameter**

port [in] Specify GPIO port.

0: PT6 1: PT7 2: PT8

3: PT9 4: PT10

ui32Data [in] The specified pin of the GPIO port. It could be 0~0xFF.

The operation mode of the pin will be set if the bit of i32Bit is equal to 1

The operation mode of the pin will not be change if the bit of i32Bit is equal to 0

- **Include**

Peripheral_lib/DrvGPIO.h

- **Return Value**

0: Operation successful

Other : Incorrect argument

- **Example**

```
/* configure PT6.1 and PT6.4 */  
DrvGPIO_LCDClrPorts (E_PT6, 0x12);
```

5.4.17 DrvGPIO_ LCDSetBit

- **Prototype**

unsigned char DrvGPIO_LCDIOSetBit (E_DRVGPIO_PORT uport, unsigned int i32Bit)

- **Description**

Set the output status value of the specified GPIO(PT6~PT10) to 1

Configure the register PT6 0X40850[17][1]/ 0X40854[17][1]/ 0X40858[17][1] / 0X4085C[17][1]
PT7 0X40860[17][1]/ 0X40864[17][1]/ 0X40868[17][1] / 0X4086C[17][1]
PT8 0X40870[17][1]/ 0X40874[17][1]/ 0X40878[17][1] / 0X4087C[17][1]
PT9 0X40880[17][1]/ 0X40884[17][1]/ 0X40888[17][1] / 0X4088C[17][1]
PT10 0X40890[17][1]

- **Parameter**

port [in] Specify GPIO port.

0: PT6 1: PT7 2: PT8

3: PT9 4: PT10

i32Bit [in] The specified pin of the GPIO port. It could be 0~7.

- **Include**

Peripheral_lib/DrvGPIO.h

- **Return Value**

0: Operation successful

Other : Incorrect argument

- **Example**

```
/* configure PT6.0 as output mode*/  
DrvGPIO_LCDIOOpen (E_PT6, 1, E_IO_OUTPUT);  
/* configure PT6.0 output 1 */  
DrvGPIO_LCDIOSetBit (E_PT6, 0);
```

5.4.18 DrvGPIO_ LCDClrBit

- **Prototype**

unsigned char DrvGPIO_LCDIOClrBit (E_DRVGPIO_PORT uport, unsigned int i32Bit)

- **Description**

Set the output status value of the specified GPIO(PT6~PT10) to 0

Configure the register PT6 0X40850[17][1]/ 0X40854[17][1]/ 0X40858[17][1] / 0X4085C[17][1]
PT7 0X40860[17][1]/ 0X40864[17][1]/ 0X40868[17][1] / 0X4086C[17][1]

PT8 0X40870[17][1]/ 0X40874[17][1]/ 0X40878[17][1] / 0X4087C[17][1]
PT9 0X40880[17][1]/ 0X40884[17][1]/ 0X40888[17][1] / 0X4088C[17][1]
PT10 0X40890[17][1]

- **Parameter**

port [in] Specify GPIO port.

0: PT6 1: PT7 2: PT8

3: PT9 4: PT10

i32Bit [in] The specified pin of the GPIO port. It could be 0~7.

- **Include**

Peripheral_lib/DrvGPIO.h

- **Return Value**

0: Operation successful

Other : Incorrect argument

- **Example**

```
/* configure PT6.0 output 0 */
```

```
DrvGPIO_LCDIOSetBit (E_PT6, 0);
```

5.4.19 DrvGPIO_LCDIOGetPorts

- **Prototype**

unsigned char DrvGPIO_LCDIOGetPort (E_DRVGPIOPORT port)

- **Description**

Get the input port value from the specified GPIO(PT6~PT10) port.

Read the register PT6 0X40850[16][0]/ 0X40854[16][0]/ 0X40858[16][0] / 0X4085C[16][0]

PT7 0X40860[16][0]/ 0X40864[16][0]/ 0X40868[16][0] / 0X4086C[16][0]

PT8 0X40870[16][0]/ 0X40874[16][0]/ 0X40878[16][0] / 0X4087C[16][0]

PT9 0X40880[16][0]/ 0X40884[16][0]/ 0X40888[16][0] / 0X4088C[16][0]

PT10 0X40890[16][0]

- **Parameter**

port [in] specify GPIO port. It could be 0~4.

0: PT6 1: PT7 2: PT8

3: PT9 4: PT10

- **Include**

Peripheral_lib/DrvGPIO.h

- **Return Value**

0 ~ 0xFF :The specified input port value

0xff000000: Incorrect argument ,

- **Example**

```
/* Get the PT6 port input data value */
```

```
uint32_t i32Port; i32Port = DrvGPIO_LCDIOGetPorts (E_PT6);
```

5.4.20 DrvGPIO_LCDIOGetBit

- **Prototype**

```
unsigned int DrvGPIO_LCDIOGetBit (E_DRVGPIO_PORT port, uint8_t u32Bit)
```

- **Description**

Get the input port value from the specified GPIO(PT6~PT10) port.

Read the register PT6 0X40850[16][0]/ 0X40854[16][0]/ 0X40858[16][0] / 0X4085C[16][0]
PT7 0X40860[16][0]/ 0X40864[16][0]/ 0X40868[16][0] / 0X4086C[16][0]
PT8 0X40870[16][0]/ 0X40874[16][0]/ 0X40878[16][0] / 0X4087C[16][0]
PT9 0X40880[16][0]/ 0X40884[16][0]/ 0X40888[16][0] / 0X4088C[16][0]
PT10 0X40890[16][0]

- **Parameter**

port [in] Specify GPIO port. It could be 0~4.

0: PT6 1: PT7 2: PT8

3: PT9 4: PT10

u32Bit [in] The specified pin of the GPIO port. It could be 0~7.

- **Include**

Peripheral_lib/DrvGPIO.h

- **Return Value**

0/1 :The specified input port value

0xff: Incorrect argument ,

- **Example**

```
uint32_t i32BitValue;  
/* Configure PT6-1 as GPIO input mode, and read the input value of status*/  
DrvGPIO_LCDIOOpen(E_PT6, 1, E_IO_INPUT);  
i32BitValue = DrvGPIO_LCDIOGetBit (E_PT6, 1);  
if (u32BitValue == 1)  
{  
    printf("PT6-1 pin status is high.\n");  
}  
else  
{  
    printf("PT6-1 pin status is low.\n");  
}
```

5.4.21 DrvGPIO_EnableAnalogPin

- **Prototype**

unsigned char DrvGPIO_EnableAnalogPin(short port, unsigned int i32Bit)

- **Description**

Close the digital operation mode of the specified GPIO pin, it could be input/output/external interrupt/pull-up/interrupt trigger edge and open analog operation mode

Configure the register PT1 0X40800[23:16] / 0X40800[7:0] / 0X40804[23:16] / 0X40010[23:16]

PT2 0X40810[23:16] / 0X40810[7:0] / 0X40814[23:16] / 0X40014[23:16]

PT3 0X40820[23:16] / 0X40820[7:0] / 0X40824[23:16]

- **Parameter**

port [in] specify GPIO port. It could be 1~3

1: PT1 2: PT2

3: PT3

i32Bit [in] Specify pin of the GPIO port. It could be 0~0xFF.

The operation mode of the pin will be change if the bit of i32Bit is equal to 1

The operation mode of the pin will not be change if the bit of i32Bit is equal to 0

- **Include**

Peripheral_lib/DrvGPIO.h

- **Return Value**

0: Operation successful

1 : Incorrect argument

- **Example**

```
/* Close PT3.1/PT3.3/PT3.5/PT3.7 digital operation mode*/
```

```
DrvGPIO_Open(E_PT3, 0XAA, E_IO_INPUT);
```

```
DrvGPIO_Open(E_PT3, 0X55, E_IO_OUTPUT);
```

```
DrvGPIO_Open(E_PT3, 0XAA, E_IO_PullHigh);
```

```
DrvGPIO_IntTrigger(E_PT3, 0XAA, E_N_Edge);
```

```
DrvGPIO_EnableAnalogPin(E_PT3, 0XAA);
```

5.4.22 DrvGPIO_PT1_EnableINPUT

- **Prototype**

void DrvGPIO_PT1_EnableINPUT(short int ubit)

- **Description**

Enable the input mode of the specified GPIO pin .

Configure the register 0x40804[23:16]

- **Parameter**

ubit[in] specified PT1 pin. It could be 0~0xff

Set the specified GPIO pin to the input operation mode if the bit of ubit is equal to 1

The operation mode of specified GPIO pin would not change if the bit of ubit is equal to 0

- **Include**

Peripheral_lib/DrvGPIO.h

- **Return Value**

None

- **Example**

```
/* set PT1.0/PT1.1 as input mode*/  
DrvGPIO_PT1_EnableINPUT (0X01||0x02);
```

5.4.23 DrvGPIO_PT1_DisableINPUT

- **Prototype**

```
void DrvGPIO_PT1_DisableINPUT(short int ubit)
```

- **Description**

Disable the input mode of the specified GPIO pin .

Configure the register 0x40804[23:16]

- **Parameter**

ubit[in] specified PT1 pin. It could be 0~0xff

Disable the input mode of the specified GPIO pin if the specified bit of ubit is equal to 1

The operation mode of specified GPIO pin would not change if the specified bit of ubit is equal to 0

- **Include**

Peripheral_lib/DrvGPIO.h

- **Return Value**

None

- **Example**

```
/* disable the input mode of PT1.0/PT1.1*/  
DrvGPIO_PT1_DisableINPUT (0X01||0x02);
```

5.4.24 DrvGPIO_PT1_EnablePullHigh

- **Prototype**

```
void DrvGPIO_PT1_EnablePullHigh (short int ubit)
```

- **Description**

Enable the pull up of the specified GPIO pin .

Configure the register 0x40800[23:16]

- **Parameter**

ubit[in] specified PT1 pin. It could be 0~0xff

Set the specified GPIO pin to enable pull-up if the bit of ubit is equal to 1

The status of specified GPIO pin would not change if the bit of ubit is equal to 0

- **Include**

Peripheral_lib/DrvGPIO.h

- **Return Value**

None

- **Example**

```
/* enable the pull up of PT1.0/PT1.1 */
```

```
DrvGPIO_PT1_EnablePullHigh(0X01||0x02);
```

5.4.25 DrvGPIO_PT1_DisablePullHigh

- **Prototype**

```
void DrvGPIO_PT1_DisablePullHigh (short int ubit)
```

- **Description**

Disable the pull up of the specified GPIO pin .

Configure the register 0x40800[23:16]

- **Parameter**

ubit[in] specified PT1 pin. It could be 0~0xff

Set the specified GPIO pin to disable pull-up if the bit of ubit is equal to 1

The status of specified GPIO pin would not change if the bit of ubit is equal to 0

- **Include**

Peripheral_lib/DrvGPIO.h

- **Return Value**

None

- **Example**

```
/* disable the pull up of PT1.0/PT1.1 */
```

```
DrvGPIO_PT1_DisablePullHigh(0X01||0x02);
```

5.4.26 DrvGPIO_PT1_EnableOUTPUT

- **Prototype**

```
void DrvGPIO_PT1_EnableOUTPUT(short int ubit)
```

- **Description**

Enable the output mode of the specified GPIO pin .

Configure the register 0x40800[7:0]

- **Parameter**

ubit[in] specified PT1 pin. It could be 0~0xff

Set the specified GPIO pin to the output operation mode if the specified bit of ubit is equal to 1

The operation mode of specified GPIO pin would not change if the specified bit of ubit is equal to 0

- **Include**

Peripheral_lib/DrvGPIO.h

- **Return Value**

None

- **Example**

```
/* set PT1.0/PT1.1 as output mode*/
```

```
DrvGPIO_PT1_EnableOUTPUT (0X01||0x02);
```

5.4.27 DrvGPIO_PT1_DisableOUTPUT

- **Prototype**

```
void DrvGPIO_PT1_DisableOUTPUT(short int ubit)
```

- **Description**

Disable the output mode of the specified GPIO pin .

Configure the register 0x40800[7:0]

- **Parameter**

ubit[in] specified PT1 pin. It could be 0~0xff

Disable the output mode of the specified GPIO pin if the specified bit of ubit is equal to 1

The operation mode of specified GPIO pin would not change if the specified bit of ubit is equal to 0

- **Include**

Peripheral_lib/DrvGPIO.h

- **Return Value**

None

- **Example**

```
/* disable the output mode of PT1.0/PT1.1*/
```

```
DrvGPIO_PT1_DisableOUTPUT (0X01||0x02);
```

5.4.28 DrvGPIO_PT1_EnableINT

- **Prototype**

```
void DrvGPIO_PT1_EnableINT (short int ubit)
```

- **Description**

Enable the external interrupt of the specified GPIO pin .

Configure the register 0x40010[23:16]

- **Parameter**

ubit[in] specified PT1 pin. It could be 0~0xff

Set the specified GPIO pin to enable the external interrupt if the bit of ubit is equal to 1

The status of specified GPIO pin would not change if the bit of ubit is equal to 0

- **Include**

Peripheral_lib/DrvGPIO.h

- **Return Value**

None

- **Example**

```
/* enable the external interrupt of PT1.0/PT1.1 */
```

```
DrvGPIO_PT1_EnableINT(0X01||0x02);
```

5.4.29 DrvGPIO_PT1_DisableINT

- **Prototype**

```
void DrvGPIO_PT1_DisableINT (short int ubit)
```

- **Description**

Disable the external interrupt of the specified GPIO pin .

Configure the register 0x40010[23:16]

- **Parameter**

ubit[in] specified PT1 pin. It could be 0~0xff

Set the specified GPIO pin to disable the external interrupt if the bit of ubit is equal to 1

The status of specified GPIO pin would not change if the bit of ubit is equal to 0

- **Include**

Peripheral_lib/DrvGPIO.h

- **Return Value**

None

- **Example**

```
/* disable the external interrupt of PT1.0/PT1.1 */
```

```
DrvGPIO_PT1_DisableINT(0X01||0x02);
```

5.4.30 DrvGPIO_PT1_IntTriggerPorts

- **Prototype**

```
void DrvGPIO_PT1_IntTriggerPorts(uint32_t i32Bit, uint32_t mode)
```

- **Description**

Enable the external interrupt trigger of the specified GPIO pin . Select the method of interrupt trigger.

Configure the register 0x4080c[31:0]

- **Parameter**

u32Bit [in] specified PT1 pin. It could be 0~0xff

Set the specified GPIO if the bit of u32Bit is equal to 1

Disable the interrupt trigger of specified GPIO pin if the bit of u32Bit is equal to 0

mode [in] interrupt trigger method . it could be 0~7

0 : disable GPIO interrupt trigger	1 : positive edge	2 : negative edge	3 : level change
4 : low level	5 : high level	6 : low level	7 : high level

- **Include**

Peripheral_lib/DrvGPIO.h

- **Return Value**

None

- **Example**

```
/* set the negative edge as the interrupt method of PT1.0*/  
DrvGPIO_ClkGenerator (0,1); // set the sampling frequency  
DrvGPIO_PT1_EnableINT (0X1); // enable GPIO external interrupt  
DrvGPIO_PT1_IntTriggerPorts (0x1, E_N_Edge); //configure the interrupt trigger method
```

5.4.31 DrvGPIO_PT1_IntTriggerBit

- **Prototype**

```
void DrvGPIO_PT1_IntTriggerBit(uint32_t i32Bit, uint32_t mode)
```

- **Description**

Enable the external interrupt trigger of the specified GPIO pin . select the method of interrupt trigger.
Configure the register 0x4080c[31:0]

- **Parameter**

u32Bit [in] specified PT1 pin. It could be 0~7 stand for bit7~bit0 of GPIO port

The specified GPIO pin will be set.

mode [in] interrupt trigger method . it could be 0~7

0 : disable GPIO interrupt trigger	1 : positive edge	2 : negative edge	3 : level change
4 : low level	5 : high level	6 : low level	7 : high level

- **Include**

Peripheral_lib/DrvGPIO.h

- **Return Value**

None

- **Example**

```
/* set the negative edge as the interrupt method of PT1.0*/  
DrvGPIO_ClkGenerator (0,1); // set the sampling frequency  
DrvGPIO_PT1_EnableINT (0X1); // enable GPIO external interrupt  
DrvGPIO_PT1_IntTriggerBit (0x0, E_N_Edge); //configure the interrupt trigger method
```

5.4.32 DrvGPIO_PT1_GetIntFlag

- **Prototype**

unsigned char DrvGPIO_PT1_GetIntFlag(void)

- **Description**

Get the port value from the PT1 Interrupt Trigger Source Indicator Register. If the corresponding bit of the return port value is 1, it is meaning the interrupt occurred at the corresponding bit. Otherwise, no interrupt occurred at that bit.

Read the register 0X40010[7 :0]

- **Parameter**

None

- **Include**

Peripheral_lib/DrvGPIO.h

- **Return Value**

The interrupt flag value of the specified register: 0 ~ 0Xff

- **Example**

```
/* Get PT1 interrupt flag. */  
unsigned char flag; flag=DrvGPIO_PT1_GetIntFlag ();
```

5.4.33 DrvGPIO_PT1_ClearIntFlag

- **Prototype**

unsigned char DrvGPIO_PT1_ClearIntFlag(short int uint32)

- **Description**

Clear the external interrupt flag of PT1

Configure the register 0X40010[7 :0]

- **Parameter**

u32Bit [in] specified PT1 pin. It could be 0~0xff

The each bit of u32Bit is corresponding to one pin .

Clear the corresponding interrupt flag when the specified bit of u32Bit is equal to 1

- **Include**

Peripheral_lib/DrvGPIO.h

- **Return Value**

None

- **Example**

```
/* Clear PT1.2 interrupt flag */  
DrvGPIO_PT1_ClearIntFlag(0x04);  
/* Clear PT1.3 interrupt flag*/  
DrvGPIO_PT1_ClearIntFlag(0x08);
```

5.4.34 DrvGPIO_PT1_GetPortBits

- **Prototype**

uint32_t DrvGPIO_PT1_GetPortBits (void)

- **Description**

Get the input port data from the specified GPIO port.

Read the register 0x40808[7:0]

- **Parameter**

None

- **Include**

Peripheral_lib/DrvGPIO.h

- **Return Value**

0 ~ 0xFF :The input value of specified port

- **Example**

```
/* Get the PT1 port input data value */  
uint32_t i32Port; i32Port = DrvGPIO_PT1_GetPortBits ();
```

5.4.35 DrvGPIO_PT1_SetPortBits

- **Prototype**

void DrvGPIO_PT1_SetPortBits (unsigned char ui32Data)

- **Description**

Set the output port value to the specified pin.

Configure the register 0x40804[7:0]

- **Parameter**

i32Data [in] specify which bit to be set. It could be 0~0xFF

The each bit of i32Data corresponding to one pin .

Output data of the specified GPIO pin will be set 1 when the bit of u32Bit is equal to 1

- **Include**

Peripheral_lib/DrvGPIO.h

- **Return Value**

None

- **Example**

```
/* Set PT1.1 PT1.4 */  
DrvGPIO_PT1_SetPortBits (0x12);
```

5.4.36 DrvGPIO_PT1_ClrPortBits

- **Prototype**

void DrvGPIO_PT1_ClrPortBits (unsigned int ui32Data)

- **Description**

Clear the output data of the specified pin.

Configure the register 0x40804[7:0]

- **Parameter**

i32Data [in] specify which bit to be clear. It could be 0~0xFF

The each bit of i32Data corresponding to one pin .

Output data of the specified GPIO pin will be clear when the corresponding bit of u32Bit is equal to 1

- **Include**

Peripheral_lib/DrvGPIO.h

- **Return Value**

None

- **Example**

```
/* clear PT1.1 PT1.4 */
```

```
DrvGPIO_PT1_ClrPortBits (0x12);
```

5.4.37 DrvGPIO_PT2_EnableINPUT

- **Prototype**

void DrvGPIO_PT2_EnableINPUT(short int ubit)

- **Description**

Enable the input mode of the specified GPIO pin .

Configure the register 0x40814[23:16]

- **Parameter**

ubit[in] specified PT1 pin. It could be 0~0xff

Set the specified GPIO pin to the input operation mode if the bit of ubit is equal to 1

The operation mode of specified GPIO pin would not change if the bit of ubit is equal to 0

- **Include**

Peripheral_lib/DrvGPIO.h

- **Return Value**

None

- **Example**

```
/* set PT2.0/PT2.1 as input mode*/
```

```
DrvGPIO_PT2_EnableINPUT (0X01||0x02);
```

5.4.38 DrvGPIO_PT2_DisableINPUT

- **Prototype**

void DrvGPIO_PT2_DisableINPUT(short int ubit)

- **Description**

Disable the input mode of the specified GPIO pin .

Configure the register 0x40814[23:16]

- **Parameter**

ubit[in] specified PT2 pin. It could be 0~0xff

Disable the input mode of the specified GPIO pin if the bit of ubit is equal to 1

The operation mode of specified GPIO pin would not change if the bit of ubit is equal to 0

- **Include**

Peripheral_lib/DrvGPIO.h

- **Return Value**

None

- **Example**

```
/* disable the input mode of PT2.0/PT2.1*/  
DrvGPIO_PT2_DisableINPUT (0X01||0x02);
```

5.4.39 DrvGPIO_PT2_EnablePullHigh

- **Prototype**

void DrvGPIO_PT2_EnablePullHigh (short int ubit)

- **Description**

Enable the pull up of the specified GPIO pin .

Configure the register 0x40810[23:16]

- **Parameter**

ubit[in] specified PT2 pin. It could be 0~0xff

Set the specified GPIO pin to enable pull-up if the bit of ubit is equal to 1

The status of specified GPIO pin would not change if the bit of ubit is equal to 0

- **Include**

Peripheral_lib/DrvGPIO.h

- **Return Value**

None

- **Example**

```
/* enable the pull up of PT2.0/PT2.1 */  
DrvGPIO_PT2_EnablePullHigh(0X01||0x02);
```

5.4.40 DrvGPIO_PT2_DisablePullHigh

- **Prototype**

void DrvGPIO_PT2_DisablePullHigh (short int ubit)

- **Description**

Disable the pull up of the specified GPIO pin .

Configure the register 0x40810[23:16]

- **Parameter**

ubit[in] specified PT2 pin. It could be 0~0xff

Set the specified GPIO pin to disable pull-up if the bit of ubit is equal to 1

The status of specified GPIO pin would not change if the bit of ubit is equal to 0

- **Include**

Peripheral_lib/DrvGPIO.h

- **Return Value**

None

- **Example**

```
/* disable the pull up of PT2.0/PT2.1 */
```

```
DrvGPIO_PT2_DisablePullHigh(0X01||0x02);
```

5.4.41 DrvGPIO_PT2_EnableOUTPUT

- **Prototype**

void DrvGPIO_PT2_EnableOUTPUT(short int ubit)

- **Description**

Enable the output mode of the specified GPIO pin .

Configure the register 0x40810[7:0]

- **Parameter**

ubit[in] specified PT2 pin. It could be 0~0xff

Set the specified GPIO pin to the output operation mode if the bit of ubit is equal to 1

The operation mode of specified GPIO pin would not change if the bit of ubit is equal to 0

- **Include**

Peripheral_lib/DrvGPIO.h

- **Return Value**

None

- **Example**

```
/* set PT2.0/PT2.1 as output mode*/
```

```
DrvGPIO_PT2_EnableOUTPUT (0X01||0x02);
```

5.4.42 DrvGPIO_PT2_DisableOUTPUT

- **Prototype**

void DrvGPIO_PT2_DisableOUTPUT(short int ubit)

- **Description**

Disable the output mode of the specified GPIO pin .

Configure the register 0x40810[7:0]

- **Parameter**

ubit[in] specified PT2 pin. It could be 0~0xff

Disable the output mode of the specified GPIO pin if the bit of ubit is equal to 1

The operation mode of specified GPIO pin would not change if the bit of ubit is equal to 0

- **Include**

Peripheral_lib/DrvGPIO.h

- **Return Value**

None

- **Example**

```
/* disable the output mode of PT2.0/PT2.1*/
```

```
DrvGPIO_PT2_DisableOUTPUT (0X01||0x02);
```

5.4.43 DrvGPIO_PT2_EnableINT

- **Prototype**

void DrvGPIO_PT2_EnableINT (short int ubit)

- **Description**

Enable the external interrupt of the specified GPIO pin .

Configure the register 0x40014[23:16]

- **Parameter**

ubit[in] specified PT2 pin. It could be 0~0xff

Set the specified GPIO pin to enable the external interrupt if the bit of ubit is equal to 1

The status of specified GPIO pin would not change if the bit of ubit is equal to 0

- **Include**

Peripheral_lib/DrvGPIO.h

- **Return Value**

None

- **Example**

```
/* enable the external interrupt of PT2.0/PT2.1 */
```

```
DrvGPIO_PT2_EnableINT(0X01||0x02);
```

5.4.44 DrvGPIO_PT2_DisableINT

- **Prototype**

void DrvGPIO_PT2_DisableINT (short int ubit)

- **Description**

Disable the external interrupt of the specified GPIO pin .

Configure the register 0x40014[23:16]

- **Parameter**

ubit[in] specified PT2 pin. It could be 0~0xff

Set the specified GPIO pin to disable the external interrupt if the bit of ubit is equal to 1

The status of specified GPIO pin would not change if the bit of ubit is equal to 0

- **Include**

Peripheral_lib/DrvGPIO.h

- **Return Value**

None

- **Example**

```
/* disable the external interrupt of PT2.0/PT2.1 */
```

```
DrvGPIO_PT2_DisableINT(0X01||0x02);
```

5.4.45 DrvGPIO_PT2_IntTriggerPorts

- **Prototype**

void DrvGPIO_PT2_IntTriggerPorts(uint32_t i32Bit, uint32_t mode)

- **Description**

Enable the external interrupt trigger of the specified GPIO pin . select the method of interrupt trigger.

Configure the register 0x4081c[31:0]

- **Parameter**

u32Bit [in] specified PT2 pin. It could be 0~0xff

Set the specified GPIO if the bit of u32Bit is equal to 1

Disable the interrupt trigger of specified GPIO pin if the bit of u32Bit is equal to 0

mode [in] interrupt trigger method . it could be 0~7

0 : disable GPIO interrupt trigger 1 : positive edge 2 : negative edge 3 : level change

4 : low level 5 : high level 6 : low level 7 : high level

- **Include**

Peripheral_lib/DrvGPIO.h

- **Return Value**

None

- **Example**

```
/* set the negative edge as the interrupt method of PT2.0*/
```

```
DrvGPIO_ClkGenerator (0,1); // set the sampling frequency
```

```
DrvGPIO_PT2_EnableINT (0X1); // enable GPIO external interrupt  
DrvGPIO_PT2_IntTriggerPorts (0x1, E_N_Edge); //configure the interrupt trigger method
```

5.4.46 DrvGPIO_PT2_IntTriggerBit

- **Prototype**

```
void DrvGPIO_PT2_IntTriggerBit(uint32_t i32Bit, uint32_t mode)
```

- **Description**

Enable the external interrupt trigger of the specified GPIO pin . select the method of interrupt trigger.
Configure the register 0x4081c[31:0]

- **Parameter**

u32Bit [in] specified PT2 pin. It could be 0~7 stand for bit7~bit0 of GPIO port

The specified GPIO pin will be set.

mode [in] interrupt trigger method . it could be 0~7

0 : disable GPIO interrupt trigger	1 : positive edge	2 : negative edge	3 : level change
4 : low level	5 : high level	6 : low level	7 : high level

- **Include**

Peripheral_lib/DrvGPIO.h

- **Return Value**

None

- **Example**

```
/* set the negative edge as the interrupt method of PT2.0*/  
DrvGPIO_ClkGenerator (0,1); // set the sampling frequency  
DrvGPIO_PT2_EnableINT (0X1); // enable GPIO external interrupt  
DrvGPIO_PT2_IntTriggerBit (0x0, E_N_Edge); //configure the interrupt trigger method
```

5.4.47 DrvGPIO_PT2_GetIntFlag

- **Prototype**

```
unsigned char DrvGPIO_PT2_GetIntFlag(void)
```

- **Description**

Get the port value from the PT2 Interrupt Trigger Source Indicator Register. If the corresponding bit of the return port value is 1, it is meaning the interrupt occurred at the corresponding bit. Otherwise, no interrupt occurred at that bit.

Read the register 0X40014[7 :0]

- **Parameter**

None

- **Include**

Peripheral_lib/DrvGPIO.h

- **Return Value**

The interrupt flag value of the specified register: 0 ~ 0Xff

- **Example**

```
/* Get PT2 interrupt flag. */  
unsigned char flag; flag=DrvGPIO_PT2_GetIntFlag ();
```

5.4.48 DrvGPIO_PT2_ClearIntFlag

- **Prototype**

unsigned char DrvGPIO_PT2_ClearIntFlag(short int uint32)

- **Description**

Clear the external interrupt flag of PT2

Configure the register 0X40014[7 :0]

- **Parameter**

u32Bit [in] specified PT2 pin. It could be 0~0xff

The each bit of u32Bit corresponding to one pin .

Clear the corresponding interrupt flag when the specified bit of u32Bit is equal to 1

- **Include**

Peripheral_lib/DrvGPIO.h

- **Return Value**

None

- **Example**

```
/* Clear PT2.2 interrupt flag */  
DrvGPIO_PT2_ClearIntFlag(0x04);  
/* Clear PT2.3 interrupt flag*/  
DrvGPIO_PT2_ClearIntFlag(0x08);
```

5.4.49 DrvGPIO_PT2_GetPortBits

- **Prototype**

unsigned char DrvGPIO_PT2_GetPortBits (void)

- **Description**

Get the input port value from the specified GPIO port.

Read the register 0x40818[7:0]

- **Parameter**

None

- **Include**

Peripheral_lib/DrvGPIO.h

- **Return Value**

0 ~ 0xFF :The input value of specified port

- **Example**

```
/* Get the PT2 port input data value */  
uint32_t i32Port; i32Port = DrvGPIO_PT2_GetPortBits ();
```

5.4.50 DrvGPIO_PT2_SetPortBits

- **Prototype**

```
void DrvGPIO_PT2_SetPortBits (unsigned char ui32Data)
```

- **Description**

Set the output port value to the specified pin.

Read the register 0x40814[7:0]

- **Parameter**

i32Data [in] specify which bit to be set. It could be 0~0xFF

The each bit of i32Data corresponding to one pin .

Output data of the specified GPIO pin will be set 1 when the bit of u32Bit is equal to 1

- **Include**

Peripheral_lib/DrvGPIO.h

- **Return Value**

None

- **Example**

```
/* Set PT2.1 PT2.4 */  
DrvGPIO_PT2_SetPortBits (0x12);
```

5.4.51 DrvGPIO_PT2_ClrPortBits

- **Prototype**

```
void DrvGPIO_PT2_ClrPortBits (unsigned int ui32Data)
```

- **Description**

Clear the output data of the specified pin.

Read the register 0x40814[7:0]

- **Parameter**

i32Data [in] specify which bit to be clear. It could be 0~0xFF

The each bit of i32Data corresponding to one pin .

Output data of the specified GPIO pin will be clear when the corresponding bit of u32Bit is equal to 1

- **Include**

Peripheral_lib/DrvGPIO.h

- **Return Value**

None

- **Example**

```
/* clear PT2.1 PT2.4 */  
DrvGPIO_PT2_ClrPortBits (0x12);
```

5.4.52 DrvGPIO_PT3_EnableINPUT

- **Prototype**

```
void DrvGPIO_PT3_EnableINPUT(short int ubit)
```

- **Description**

Enable the input mode of the specified GPIO pin .
Configure the register 0x40824[23:16]

- **Parameter**

ubit[in] specified PT3 pin. It could be 0~0xff
Set the specified GPIO pin to the input operation mode if the bit of ubit is equal to 1
The operation mode of specified GPIO pin would not change if the bit of ubit is equal to 0

- **Include**

Peripheral_lib/DrvGPIO.h

- **Return Value**

None

- **Example**

```
/* set PT3.0/PT3.1 as input mode*/  
DrvGPIO_PT3_EnableINPUT (0X01||0x02);
```

5.4.53 DrvGPIO_PT3_DisableINPUT

- **Prototype**

```
void DrvGPIO_PT3_DisableINPUT(short int ubit)
```

- **Description**

Disable the input mode of the specified GPIO pin .
Configure the register 0x40824[23:16]

- **Parameter**

ubit[in] specified PT3 pin. It could be 0~0xff
Disable the input mode of the specified GPIO pin if the specified bit of ubit is equal to 1
The operation mode of specified GPIO pin would not change if the specified bit of ubit is equal to 0

- **Include**

Peripheral_lib/DrvGPIO.h

- **Return Value**

None

- **Example**

```
/* disable the input mode of PT3.0/PT3.1*/  
DrvGPIO_PT3_DisableINPUT (0X01||0x02);
```

5.4.54 DrvGPIO_PT3_EnablePullHigh

- **Prototype**

```
void DrvGPIO_PT3_EnablePullHigh (short int ubit)
```

- **Description**

Enable the pull up of the specified GPIO pin .
Configure the register 0x40820[23:16]

- **Parameter**

ubit[in] specified PT3 pin. It could be 0~0xff
Set the specified GPIO pin to enable pull-up if the bit of ubit is equal to 1
The status of specified GPIO pin would not change if the bit of ubit is equal to 0

- **Include**

Peripheral_lib/DrvGPIO.h

- **Return Value**

None

- **Example**

```
/* enable the pull up of PT3.0/PT3.1 */  
DrvGPIO_PT3_EnablePullHigh(0X01||0x02);
```

5.4.55 DrvGPIO_PT3_DisablePullHigh

- **Prototype**

```
void DrvGPIO_PT3_DisablePullHigh (short int ubit)
```

- **Description**

Disable the pull up of the specified GPIO pin .
Configure the register 0x40820[23:16]

- **Parameter**

ubit[in] specified PT3 pin. It could be 0~0xff
Set the specified GPIO pin to disable pull-up if the bit of ubit is equal to 1
The status of specified GPIO pin would not change if the bit of ubit is equal to 0

- **Include**

Peripheral_lib/DrvGPIO.h

- **Return Value**

None

- **Example**

```
/* disable the pull up of PT3.0/PT3.1 */  
DrvGPIO_PT3_DisablePullHigh(0X01||0x02);
```

5.4.56 DrvGPIO_PT3_EnableOUTPUT

- **Prototype**

```
void DrvGPIO_PT3_EnableOUTPUT(short int ubit)
```

- **Description**

Enable the output mode of the specified GPIO pin .
Configure the register 0x40820[7:0]

- **Parameter**

ubit[in] specified PT3 pin. It could be 0~0xff

Set the specified GPIO pin to the output operation mode if the specified bit of ubit is equal to 1

The operation mode of specified GPIO pin would not change if the specified bit of ubit is equal to 0

- **Include**

Peripheral_lib/DrvGPIO.h

- **Return Value**

None

- **Example**

```
/* set PT3.0/PT3.1 as output mode*/  
DrvGPIO_PT3_EnableOUTPUT (0X01||0x02);
```

5.4.57 DrvGPIO_PT3_DisableOUTPUT

- **Prototype**

```
void DrvGPIO_PT3_DisableOUTPUT(short int ubit)
```

- **Description**

Disable the output mode of the specified GPIO pin .
Configure the register 0x40820[7:0]

- **Parameter**

ubit[in] specified PT3 pin. It could be 0~0xff

Disable the output mode of the specified GPIO pin if the specified bit of ubit is equal to 1

The operation mode of specified GPIO pin would not change if the specified bit of ubit is equal to 0

- **Include**

Peripheral_lib/DrvGPIO.h

- **Return Value**

None

- **Example**

```
/* disable the output mode of PT3.0/PT3.1*/  
DrvGPIO_PT3_DisableOUTPUT (0X01||0x02);
```

5.4.58 DrvGPIO_PT3_GetPortBits

- **Prototype**

```
uint32_t DrvGPIO_PT3_GetPortBits (void)
```

- **Description**

Get the input port data from the specified GPIO port.
Read the register 0x40828[7:0]

- **Parameter**

None

- **Include**

Peripheral_lib/DrvGPIO.h

- **Return Value**

0 ~ 0xFF :The input value of specified port

- **Example**

```
/* Get the PT3 port input data value */  
uint32_t i32Port; i32Port = DrvGPIO_PT3_GetPortBits ();
```

5.4.59 DrvGPIO_PT3_SetPortBits

- **Prototype**

```
void DrvGPIO_PT3_SetPortBits (unsigned char ui32Data)
```

- **Description**

Set the output port value to the specified pin.
Read the register 0x40824[7:0]

- **Parameter**

i32Data [in] specify which bit to be set. It could be 0~0xFF

The each bit of i32Data corresponding to one pin .

Output data of the specified GPIO pin will be set 1 when the bit of u32Bit is equal to 1

- **Include**

Peripheral_lib/DrvGPIO.h

- **Return Value**

None

- **Example**

```
/* Set PT3.1 PT3.4 */  
DrvGPIO_PT3_SetPortBits (0x12);
```

5.4.60 DrvGPIO_PT3_ClrPortBits

- **Prototype**

```
void DrvGPIO_PT3_ClrPortBits (unsigned int ui32Data)
```

- **Description**

Clear the output data of the specified pin.

Configure the register 0x40824[7:0]

- **Parameter**

i32Data [in] specify which bit to be clear. It could be 0~0xFF

The each bit of i32Data corresponding to one pin .

Output data of the specified GPIO pin will be clear when the corresponding bit of u32Bit is equal to 1

- **Include**

Peripheral_lib/DrvGPIO.h

- **Return Value**

None

- **Example**

```
/* clear PT3.1 PT3.4 */  
DrvGPIO_PT3_ClrPortBits (0x12);
```

5.4.61 DrvGPIO_PT6_EnableINPUT

- **Prototype**

```
void DrvGPIO_PT6_EnableINPUT(short int ubit)
```

- **Description**

Enable the input mode of the specified GPIO pin .

Configure the register 0X40850[18][2]/ 0X40854[18][2]/ 0X40858[18][2] / 0X4085C[18][2]

- **Parameter**

ubit[in] specified PT6pin. It could be 0~0xff

Set the specified GPIO pin to the input operation mode if the bit of ubit is equal to 1

The operation mode of specified GPIO pin would not change if the bit of ubit is equal to 0

- **Include**

Peripheral_lib/DrvGPIO.h

- **Return Value**

None

- **Example**

```
/* set PT6.0/PT6.1 as input mode*/  
DrvGPIO_PT6_EnableINPUT (0X01||0x02);
```

5.4.62 DrvGPIO_PT6_DisableINPUT

- **Prototype**

```
void DrvGPIO_PT6_DisableINPUT(short int ubit)
```

- **Description**

Disable the input mode of the specified GPIO pin .

Configure the register 0X40850[18][2]/ 0X40854[18][2]/ 0X40858[18][2] / 0X4085C[18][2]

- **Parameter**

ubit[in] specified PT6 pin. It could be 0~0xff

Disable the input mode of the specified GPIO pin if the specified bit of ubit is equal to 1

The operation mode of specified GPIO pin would not change if the specified bit of ubit is equal to 0

- **Include**

Peripheral_lib/DrvGPIO.h

- **Return Value**

None

- **Example**

```
/* disable the input mode of PT6.0/PT6.1*/  
DrvGPIO_PT6_DisableINPUT (0X01||0x02);
```

5.4.63 DrvGPIO_PT6_EnableOUTPUT

- **Prototype**

```
void DrvGPIO_PT6_EnableOUTPUT(short int ubit)
```

- **Description**

Enable the output mode of the specified GPIO pin .

Configure the register 0X40850[19][3]/ 0X40854[19][3]0X40858[19][3] / 0X4085C[19][3]

- **Parameter**

ubit[in] specified PT6 pin. It could be 0~0xff

Set the specified GPIO pin to the output operation mode if the specified bit of ubit is equal to 1

The operation mode of specified GPIO pin would not change if the specified bit of ubit is equal to 0

- **Include**

Peripheral_lib/DrvGPIO.h

- **Return Value**

None

- **Example**

```
/* set PT6.0/PT6.1 as output mode*/  
DrvGPIO_PT6_EnableOUTPUT (0X01||0x02);
```

5.4.64 DrvGPIO_PT6_DisableOUTPUT

- **Prototype**

```
void DrvGPIO_PT6_DisableOUTPUT(short int ubit)
```

- **Description**

Disable the output mode of the specified GPIO pin .

Configure the register 0X40850[19][3]/ 0X40854[19][3]0X40858[19][3] / 0X4085C[19][3]

- **Parameter**

ubit[in] specified PT6 pin. It could be 0~0xff

Disable the output mode of the specified GPIO pin if the specified bit of ubit is equal to 1

The operation mode of specified GPIO pin would not change if the specified bit of ubit is equal to 0

- **Include**

Peripheral_lib/DrvGPIO.h

- **Return Value**

None

- **Example**

```
/* disable the output mode of PT6.0/PT6.1*/  
DrvGPIO_PT6_DisableOUTPUT (0X01||0x02);
```

5.4.65 DrvGPIO_PT6_GetPortBits

- **Prototype**

```
uint32_t DrvGPIO_PT6_GetPortBits (void)
```

- **Description**

Get the input port data from the specified GPIO port.

Read the register 0X40850[16][0]/ 0X40854[16][0]/ 0X40858[16][0] / 0X4085C[16][0]

- **Parameter**

None

- **Include**

Peripheral_lib/DrvGPIO.h

- **Return Value**

0 ~ 0xFF :The input value of specified port

- **Example**

```
/* Get the PT6 port input data value */
```

```
uint32_t i32Port; i32Port = DrvGPIO_PT6_GetPortBits ();
```

5.4.66 DrvGPIO_PT6_SetPortBits

- **Prototype**

```
void DrvGPIO_PT6_SetPortBits (unsigned char ui32Data)
```

- **Description**

Set the output port value to the specified pin.

Configure the register 0X40850[17][1]/ 0X40854[17][1]/ 0X40858[17][1] / 0X4085C[17][1]

- **Parameter**

i32Data [in] specify which bit to be set. It could be 0~0xFF

The each bit of i32Data corresponding to one pin .

Output data of the specified GPIO pin will be set 1 when the bit of u32Bit is equal to 1

- **Include**

Peripheral_lib/DrvGPIO.h

- **Return Value**

None

- **Example**

```
/* Set PT6.1 PT6.4 */
```

```
DrvGPIO_PT6_SetPortBits (0x12);
```

5.4.67 DrvGPIO_PT6_ClrPortBits

- **Prototype**

```
void DrvGPIO_PT6_ClrPortBits (unsigned int ui32Data)
```

- **Description**

Clear the output data of the specified pin.

Configure the register 0X40850[17][1]/ 0X40854[17][1]/ 0X40858[17][1] / 0X4085C[17][1]

- **Parameter**

i32Data [in] specify which bit to be clear. It could be 0~0xFF

The each bit of i32Data corresponding to one pin .

Output data of the specified GPIO pin will be clear when the corresponding bit of u32Bit is equal to 1

- **Include**

Peripheral_lib/DrvGPIO.h

- **Return Value**

None

- **Example**

```
/* clear PT6.1 PT6.4 */
```

DrvGPIO_PT6_ClrPortBits (0x12);

5.4.68 DrvGPIO_PT7_EnableINPUT

- **Prototype**

void DrvGPIO_PT7_EnableINPUT(short int ubit)

- **Description**

Enable the input mode of the specified GPIO pin .

Configure the 0X40860[18][2]/ 0X40864[18][2]/ 0X40868[18][2] / 0X4086C[18][2]

- **Parameter**

ubit[in] specified PT7pin. It could be 0~0xff

Set the specified GPIO pin to the input operation mode if the bit of ubit is equal to 1

The operation mode of specified GPIO pin would not change if the bit of ubit is equal to 0

- **Include**

Peripheral_lib/DrvGPIO.h

- **Return Value**

None

- **Example**

```
/* set PT7.0/PT7.1 as input mode*/
```

```
DrvGPIO_PT7_EnableINPUT (0X01||0x02);
```

5.4.69 DrvGPIO_PT7_DisableINPUT

- **Prototype**

void DrvGPIO_PT7_DisableINPUT(short int ubit)

- **Description**

Disable the input mode of the specified GPIO pin .

Configure the register 0X40860[18][2]/ 0X40864[18][2]/ 0X40868[18][2] / 0X4086C[18][2]

- **Parameter**

ubit[in] specified PT7 pin. It could be 0~0xff

Disable the input mode of the specified GPIO pin if the specified bit of ubit is equal to 1

The operation mode of specified GPIO pin would not change if the specified bit of ubit is equal to 0

- **Include**

Peripheral_lib/DrvGPIO.h

- **Return Value**

None

- **Example**

```
/* disable the input mode of PT7.0/PT7.1*/
```

DrvGPIO_PT7_DisableINPUT (0X01||0x02);

5.4.70 DrvGPIO_PT7_EnableOUTPUT

- **Prototype**

void DrvGPIO_PT7_EnableOUTPUT(short int ubit)

- **Description**

Enable the output mode of the specified GPIO pin .

Configure the register 0X40860[19][3]/ 0X40864[19][3]0X40868[19][3] / 0X4086C[19][3]

- **Parameter**

ubit[in] specified PT7 pin. It could be 0~0xff

Set the specified GPIO pin to the output operation mode if the specified bit of ubit is equal to 1

The operation mode of specified GPIO pin would not change if the specified bit of ubit is equal to 0

- **Include**

Peripheral_lib/DrvGPIO.h

- **Return Value**

None

- **Example**

/* set PT7.0/PT7.1 as output mode*/

DrvGPIO_PT7_EnableOUTPUT (0X01||0x02);

5.4.71 DrvGPIO_PT7_DisableOUTPUT

- **Prototype**

void DrvGPIO_PT7_DisableOUTPUT(short int ubit)

- **Description**

Disable the output mode of the specified GPIO pin .

Configure the register 0X40860[19][3]/ 0X40864[19][3]0X40868[19][3] / 0X4086C[19][3]

- **Parameter**

ubit[in] specified PT7 pin. It could be 0~0xff

Disable the output mode of the specified GPIO pin if the specified bit of ubit is equal to 1

The operation mode of specified GPIO pin would not change if the specified bit of ubit is equal to 0

- **Include**

Peripheral_lib/DrvGPIO.h

- **Return Value**

None

- **Example**

/* disable the output mode of PT7.0/PT7.1*/

DrvGPIO_PT7_DisableOUTPUT (0X01||0x02);

5.4.72 DrvGPIO_PT7_GetPortBits

- **Prototype**

uint32_t DrvGPIO_PT7_GetPortBits (void)

- **Description**

Get the input port data from the specified GPIO port.

Read the register 0X40860[16][0]/ 0X40864[16][0]/ 0X40868[16][0] / 0X4086C[16][0]

- **Parameter**

None

- **Include**

Peripheral_lib/DrvGPIO.h

- **Return Value**

0 ~ 0xFF :The input value of specified port

- **Example**

/* Get the PT7 port input data value */

uint32_t i32Port; i32Port = DrvGPIO_PT7_GetPortBits ();

5.4.73 DrvGPIO_PT7_SetPortBits

- **Prototype**

void DrvGPIO_PT7_SetPortBits (unsigned char ui32Data)

- **Description**

Set the output port value to the specified pin.

Configure the register 0X40860[17][1]/ 0X40864[17][1]/ 0X40868[17][1] / 0X4086C[17][1]

- **Parameter**

i32Data [in] specify which bit to be set. It could be 0~0xFF

The each bit of i32Data corresponding to one pin .

Output data of the specified GPIO pin will be set 1 when the bit of u32Bit is equal to 1

- **Include**

Peripheral_lib/DrvGPIO.h

- **Return Value**

None

- **Example**

/* Set PT7.1 PT7.4 */

DrvGPIO_PT7_SetPortBits (0x12);

5.4.74 DrvGPIO_PT7_ClrPortBits

- **Prototype**

void DrvGPIO_PT7_ClrPortBits (unsigned int ui32Data)

- **Description**

Clear the output data of the specified pin.

Configure the register 0X40860[17][1]/ 0X40864[17][1]/ 0X40868[17][1] / 0X4086C[17][1]

- **Parameter**

i32Data [in] specify which bit to be clear. It could be 0~0xFF

The each bit of i32Data corresponding to one pin .

Output data of the specified GPIO pin will be clear when the corresponding bit of u32Bit is equal to 1

- **Include**

Peripheral_lib/DrvGPIO.h

- **Return Value**

None

- **Example**

```
/* clear PT7.1 PT7.4 */
```

```
DrvGPIO_PT7_ClrPortBits (0x12);
```

5.4.75 DrvGPIO_PT8_EnableINPUT

- **Prototype**

void DrvGPIO_PT8_EnableINPUT(short int ubit)

- **Description**

Enable the input mode of the specified GPIO pin .

Configure the register 0X40870[18][2]/ 0X40874[18][2]/ 0X40878[18][2] / 0X4087C[18][2]

- **Parameter**

ubit[in] specified PT8pin. It could be 0~0xff

Set the specified GPIO pin to the input operation mode if the bit of ubit is equal to 1

The operation mode of specified GPIO pin would not change if the bit of ubit is equal to 0

- **Include**

Peripheral_lib/DrvGPIO.h

- **Return Value**

None

- **Example**

```
/* set PT8.0/PT8.1 as input mode*/
```

```
DrvGPIO_PT8_EnableINPUT (0X01||0x02);
```

5.4.76 DrvGPIO_PT8_DisableINPUT

- **Prototype**

void DrvGPIO_PT8_DisableINPUT(short int ubit)

- **Description**

Disable the input mode of the specified GPIO pin .

Configure the register 0X40870[18][2]/ 0X40874[18][2]/ 0X40878[18][2] / 0X4087C[18][2]

- **Parameter**

ubit[in] specified PT8 pin. It could be 0~0xff

Disable the input mode of the specified GPIO pin if the specified bit of ubit is equal to 1

The operation mode of specified GPIO pin would not change if the specified bit of ubit is equal to 0

- **Include**

Peripheral_lib/DrvGPIO.h

- **Return Value**

None

- **Example**

```
/* disable the input mode of PT8.0/PT8.1*/  
DrvGPIO_PT8_DisableINPUT (0X01||0x02);
```

5.4.77 DrvGPIO_PT8_EnableOUTPUT

- **Prototype**

void DrvGPIO_PT8_EnableOUTPUT(short int ubit)

- **Description**

Enable the output mode of the specified GPIO pin .

Configure the register 0X40870[19][3]/ 0X40874[19][3]0X40878[19][3] / 0X4087C[19][3]

- **Parameter**

ubit[in] specified PT8 pin. It could be 0~0xff

Set the specified GPIO pin to the output operation mode if the specified bit of ubit is equal to 1

The operation mode of specified GPIO pin would not change if the specified bit of ubit is equal to 0

- **Include**

Peripheral_lib/DrvGPIO.h

- **Return Value**

None

- **Example**

```
/* set PT8.0/PT8.1 as output mode*/  
DrvGPIO_PT8_EnableOUTPUT (0X01||0x02);
```

5.4.78 DrvGPIO_PT8_DisableOUTPUT

- **Prototype**

void DrvGPIO_PT8_DisableOUTPUT(short int ubit)

- **Description**

Disable the output mode of the specified GPIO pin .

Configure the register 0X40870[19][3]/ 0X40874[19][3]0X40878[19][3] / 0X4087C[19][3]

- **Parameter**

ubit[in] specified PT8 pin. It could be 0~0xff

Disable the output mode of the specified GPIO pin if the specified bit of ubit is equal to 1

The operation mode of specified GPIO pin would not change if the specified bit of ubit is equal to 0

- **Include**

Peripheral_lib/DrvGPIO.h

- **Return Value**

None

- **Example**

```
/* disable the output mode of PT8.0/PT8.1*/
```

```
DrvGPIO_PT8_DisableOUTPUT (0X01||0x02);
```

5.4.79 DrvGPIO_PT8_GetPortBits

- **Prototype**

uint32_t DrvGPIO_PT8_GetPortBits (void)

- **Description**

Get the input port data from the specified GPIO port.

Read the register 0X40870[16][0]/ 0X40874[16][0]/ 0X40878[16][0] / 0X4087C[16][0]

- **Parameter**

None

- **Include**

Peripheral_lib/DrvGPIO.h

- **Return Value**

0 ~ 0xFF :The input value of specified port

- **Example**

```
/* Get the PT8 port input data value */
```

```
uint32_t i32Port; i32Port = DrvGPIO_PT8_GetPortBits ();
```

5.4.80 DrvGPIO_PT8_SetPortBits

- **Prototype**

void DrvGPIO_PT8_SetPortBits (unsigned char ui32Data)

- **Description**

Set the output port value to the specified pin.

Configure the register 0X40870[17][1]/ 0X40874[17][1]/ 0X40878[17][1] / 0X4087C[17][1]

- **Parameter**

i32Data [in] specify which bit to be set. It could be 0~0xFF

The each bit of i32Data corresponding to one pin .

Output data of the specified GPIO pin will be set 1 when the bit of u32Bit is equal to 1

- **Include**

Peripheral_lib/DrvGPIO.h

- **Return Value**

None

- **Example**

```
/* Set PT8.1 PT8.4 */
```

```
DrvGPIO_PT8_SetPortBits (0x12);
```

5.4.81 DrvGPIO_PT8_ClrPortBits

- **Prototype**

void DrvGPIO_PT8_ClrPortBits (unsigned int ui32Data)

- **Description**

Clear the output data of the specified pin.

Configure the register 0X40870[17][1]/ 0X40874[17][1]/ 0X40878[17][1] / 0X4087C[17][1]

- **Parameter**

i32Data [in] specify which bit to be clear. It could be 0~0xFF

The each bit of i32Data corresponding to one pin .

Output data of the specified GPIO pin will be clear when the corresponding bit of u32Bit is equal to 1

- **Include**

Peripheral_lib/DrvGPIO.h

- **Return Value**

None

- **Example**

```
/* clear PT8.1 PT8.4 */
```

```
DrvGPIO_PT8_ClrPortBits (0x12);
```

5.4.82 DrvGPIO_PT9_EnableINPUT

- **Prototype**

void DrvGPIO_PT9_EnableINPUT(short int ubit)

- **Description**

Enable the input mode of the specified GPIO pin .

Configure the register 0X40880[18][2]/ 0X40884[18][2]/ 0X40888[18][2] / 0X4088C[18][2]

- **Parameter**

ubit[in] specified PT9pin. It could be 0~0xff

Set the specified GPIO pin to the input operation mode if the bit of ubit is equal to 1

The operation mode of specified GPIO pin would not change if the bit of ubit is equal to 0

- **Include**

Peripheral_lib/DrvGPIO.h

- **Return Value**

None

- **Example**

```
/* set PT9.0/PT9.1 as input mode*/
```

```
DrvGPIO_PT9_EnableINPUT (0X01||0x02);
```

5.4.83 DrvGPIO_PT9_DisableINPUT

- **Prototype**

void DrvGPIO_PT9_DisableINPUT(short int ubit)

- **Description**

Disable the input mode of the specified GPIO pin .

Configure the register 0X40880[18][2]/ 0X40884[18][2]/ 0X40888[18][2] / 0X4088C[18][2]

- **Parameter**

ubit[in] specified PT9 pin. It could be 0~0xff

Disable the input mode of the specified GPIO pin if the specified bit of ubit is equal to 1

The operation mode of specified GPIO pin would not change if the specified bit of ubit is equal to 0

- **Include**

Peripheral_lib/DrvGPIO.h

- **Return Value**

None

- **Example**

```
/* disable the input mode of PT9.0/PT9.1*/
```

```
DrvGPIO_PT9_DisableINPUT (0X01||0x02);
```

5.4.84 DrvGPIO_PT9_EnableOUTPUT

- **Prototype**

void DrvGPIO_PT9_EnableOUTPUT(short int ubit)

- **Description**

Enable the output mode of the specified GPIO pin .

Configure the register 0X40880[19][3]/ 0X40884[19][3]0X40888[19][3] / 0X4088C[19][3]

- **Parameter**

ubit[in] specified PT9 pin. It could be 0~0xff

Set the specified GPIO pin to the output operation mode if the specified bit of ubit is equal to 1

The operation mode of specified GPIO pin would not change if the specified bit of ubit is equal to 0

- **Include**

Peripheral_lib/DrvGPIO.h

- **Return Value**

None

- **Example**

```
/* set PT9.0/PT9.1 as output mode*/
```

```
DrvGPIO_PT9_EnableOUTPUT (0X01||0x02);
```

5.4.85 DrvGPIO_PT9_DisableOUTPUT

- **Prototype**

void DrvGPIO_PT9_DisableOUTPUT(short int ubit)

- **Description**

Disable the output mode of the specified GPIO pin .

Configure the register 0X40880[19][3]/ 0X40884[19][3]0X40888[19][3] / 0X4088C[19][3]

- **Parameter**

ubit[in] specified PT9 pin. It could be 0~0xff

Disable the output mode of the specified GPIO pin if the specified bit of ubit is equal to 1

The operation mode of specified GPIO pin would not change if the specified bit of ubit is equal to 0

- **Include**

Peripheral_lib/DrvGPIO.h

- **Return Value**

None

- **Example**

```
/* disable the output mode of PT9.0/PT9.1*/
```

```
DrvGPIO_PT9_DisableOUTPUT (0X01||0x02);
```

5.4.86 DrvGPIO_PT9_GetPortBits

- **Prototype**

uint32_t DrvGPIO_PT9_GetPortBits (void)

- **Description**

Get the input port data from the specified GPIO port.

Read the register 0X40880[16][0]/ 0X40884[16][0]/ 0X40888[16][0] / 0X4088C[16][0]

- **Parameter**

None

- **Include**

Peripheral_lib/DrvGPIO.h

- **Return Value**

0 ~ 0xFF :The input value of specified port

- **Example**

```
/* Get the PT9 port input data value */
```

```
uint32_t i32Port; i32Port = DrvGPIO_PT9_GetPortBits ();
```

5.4.87 DrvGPIO_PT9_SetPortBits

- **Prototype**

void DrvGPIO_PT9_SetPortBits (unsigned char ui32Data)

- **Description**

Set the output port value to the specified pin.

Configure the register 0X40880[17][1]/ 0X40884[17][1]/ 0X40888[17][1] / 0X4088C[17][1]

- **Parameter**

i32Data [in] specify which bit to be set. It could be 0~0xFF

The each bit of i32Data corresponding to one pin .

Output data of the specified GPIO pin will be set 1 when the bit of u32Bit is equal to 1

- **Include**

Peripheral_lib/DrvGPIO.h

- **Return Value**

None

- **Example**

```
/* Set PT9.1 PT9.4 */
```

```
DrvGPIO_PT9_SetPortBits (0x12);
```

5.4.88 DrvGPIO_PT9_ClrPortBits

- **Prototype**

void DrvGPIO_PT9_ClrPortBits (unsigned int ui32Data)

- **Description**

Clear the output data of the specified pin.

Configure the register 0X40880[17][1]/ 0X40884[17][1]/ 0X40888[17][1] / 0X4088C[17][1]

- **Parameter**

i32Data [in] specify which bit to be clear. It could be 0~0xFF

The each bit of i32Data corresponding to one pin .

Output data of the specified GPIO pin will be clear when the corresponding bit of u32Bit is equal to 1

- **Include**

Peripheral_lib/DrvGPIO.h

- **Return Value**

None

- **Example**

```
/* clear PT9.1 PT9.4 */
```

```
DrvGPIO_PT9_ClrPortBits (0x12);
```

5.4.89 DrvGPIO_PT10_EnableINPUT

- **Prototype**

```
void DrvGPIO_PT10_EnableINPUT(short int ubit)
```

- **Description**

Enable the input mode of the specified GPIO pin .

Configure the register 0X40890[18][2]

- **Parameter**

ubit[in] specified PT10pin. It could be 0~0xff

Set the specified GPIO pin to the input operation mode if the bit of ubit is equal to 1

The operation mode of specified GPIO pin would not change if the bit of ubit is equal to 0

- **Include**

Peripheral_lib/DrvGPIO.h

- **Return Value**

None

- **Example**

```
/* set PT10.0/PT10.1 as input mode*/
```

```
DrvGPIO_PT10_EnableINPUT (0X01||0x02);
```

5.4.90 DrvGPIO_PT10_DisableINPUT

- **Prototype**

```
void DrvGPIO_PT10_DisableINPUT(short int ubit)
```

- **Description**

Disable the input mode of the specified GPIO pin .
Configure the register 0X40890[18][2]

- **Parameter**

ubit[in] specified PT10 pin. It could be 0~0xff
Disable the input mode of the specified GPIO pin if the specified bit of ubit is equal to 1
The operation mode of specified GPIO pin would not change if the specified bit of ubit is equal to 0

- **Include**

Peripheral_lib/DrvGPIO.h

- **Return Value**

None

- **Example**

```
/* disable the input mode of PT10.0/PT10.1*/  
DrvGPIO_PT10_DisableINPUT (0X01||0x02);
```

5.4.91 DrvGPIO_PT10_EnableOUTPUT

- **Prototype**

```
void DrvGPIO_PT10_EnableOUTPUT(short int ubit)
```

- **Description**

Enable the output mode of the specified GPIO pin .
Configure the register 0X40890[19][3]

- **Parameter**

ubit[in] specified PT10 pin. It could be 0~0xff
Set the specified GPIO pin to the output operation mode if the specified bit of ubit is equal to 1
The operation mode of specified GPIO pin would not change if the specified bit of ubit is equal to 0

- **Include**

Peripheral_lib/DrvGPIO.h

- **Return Value**

None

- **Example**

```
/* set PT10.0/PT10.1 as output mode*/  
DrvGPIO_PT10_EnableOUTPUT (0X01||0x02);
```

5.4.92 DrvGPIO_PT10_DisableOUTPUT

- **Prototype**

```
void DrvGPIO_PT10_DisableOUTPUT(short int ubit)
```

- **Description**

Disable the output mode of the specified GPIO pin .
Configure the register 0X40890[19][3]

- **Parameter**

ubit[in] specified PT10 pin. It could be 0~0xff
Disable the output mode of the specified GPIO pin if the specified bit of ubit is equal to 1
The operation mode of specified GPIO pin would not change if the specified bit of ubit is equal to 0

- **Include**

Peripheral_lib/DrvGPIO.h

- **Return Value**

None

- **Example**

```
/* disable the output mode of PT10.0/PT10.1*/  
DrvGPIO_PT10_DisableOUTPUT (0X01||0x02);
```

5.4.93 DrvGPIO_PT10_GetPortBits

- **Prototype**

```
uint32_t DrvGPIO_PT10_GetPortBits (void)
```

- **Description**

Get the input port data from the specified GPIO port.
Read the register 0X40890[16][0]

- **Parameter**

None

- **Include**

Peripheral_lib/DrvGPIO.h

- **Return Value**

0 ~ 0xFF :The input value of specified port

- **Example**

```
/* Get the PT10 port input data value */  
uint32_t i32Port; i32Port = DrvGPIO_PT10_GetPortBits ();
```

5.4.94 DrvGPIO_PT10_SetPortBits

- **Prototype**

```
void DrvGPIO_PT10_SetPortBits (unsigned char ui32Data)
```

- **Description**

Set the output port value to the specified pin.

Configure the register 0X40890[17][1]

- **Parameter**

i32Data [in] specify which bit to be set. It could be 0~0xFF

The each bit of i32Data corresponding to one pin .

Output data of the specified GPIO pin will be set 1 when the bit of u32Bit is equal to 1

- **Include**

Peripheral_lib/DrvGPIO.h

- **Return Value**

None

- **Example**

```
/* Set PT10.1 PT10.4 */
```

```
DrvGPIO_PT10_SetPortBits (0x12);
```

5.4.95 DrvGPIO_PT10_ClrPortBits

- **Prototype**

```
void DrvGPIO_PT10_ClrPortBits (unsigned int ui32Data)
```

- **Description**

Clear the output data of the specified pin.

Configure the register 0X40890[17][1]

- **Parameter**

i32Data [in] specify which bit to be clear. It could be 0~0xFF

The each bit of i32Data corresponding to one pin .

Output data of the specified GPIO pin will be clear when the corresponding bit of u32Bit is equal to 1

- **Include**

Peripheral_lib/DrvGPIO.h

- **Return Value**

None

- **Example**

```
/* clear PT10.1 PT10.4 */
```

```
DrvGPIO_PT10_ClrPortBits (0x12);
```

5.4.96 DrvGPIO_PortIDIF

- 函数

unsigned int DrvGPIO_PortIDIF (uint32_t port)

- 函数功能

Read the PT1/PT2 condition flag of interrupt trigger when be in the external interrupt. The value depend on the interrupt trigger way. User must check the condition flag in register 0x4080c/0x4081c[31:24] to make sure the IO PIN on the corresponding initial status before get into the low power mode which waky up by the external interrupt.

Operate the register 0X4080C[31:24] and 0X4081C[31:24].

- 输入参数

port [in] the value is 1 or 2 ;

1: PT1, 2: PT2

- 包含头文件

Peripheral_lib/DrvGPIO.h

- 函数返回值

Return value is 0~0XFF, the interrupt trigger condition flag of corresponding IO PIN.

- 函数用法

/* Setting the PT1.2 as external interrupt input pin, the trigger way is negative-edge,then read the PT1.2 interrupt trigger condition flag*/

```
DrvGPIO_ClearIntFlag(E_PT1,0xff);  
DrvGPIO_Open(E_PT1,0x04,E_IO_INPUT);  
DrvGPIO_Open(E_PT1,0x04,E_IO_PuLLHigh);  
DrvGPIO_Open(E_PT1,0x04,E_IO_IntEnable);  
DrvGPIO_ClkGenerator(E_LS_CK,1);  
DrvGPIO_IntTrigger(E_PT1,0x04,E_N_Edge);  
SYS_EnableGIE(7,0x1FF);  
Unsigned int m= DrvGPIO_PortIDIF(E_PT1);
```

6. ADC Driver

6.1 Introduction

The following functions are included in ADC Manager Section.

Item	Functions	Description
01	DrvADC_POSITIVE_INPUT_CHANNEL	Positive input source
02	DrvADC_NEGATIVE_INPUT_CHANNEL	Negative input source
03	DrvADC_INPUT_CHANNEL	Set the ADC input mode
04	DrvADC_INPUT_SWITCH	ADC input short control
05	DrvADC_REF_INPUT_SHORT_CONTROL	ADC reference short control
06	DrvADC_PGA	Input signal gain
07	DrvADC_AD_GAIN	Input signal gain
08	DrvADC_GAIN	Input signal gain
09	DrvADC_SetADC_DC_OFFSET	DC offset input selection
10	DrvADC_SetADC_REFERENCE_VOLTAGE	Set the ADC reference
11	DrvADC_SetADC_FULL_REF_RANGE	Set the ADC reference
12	DrvADC_SetADC_OSR	Set the ADC OSR
13	DrvADC_CLOCK_ENABLE	Enable ADC clock
14	DrvADC_CLOCK_DISABLE	Disable ADC clock
15	DrvADC_FAST_CHOPPER	Fast chopper stable mode
16	DrvADC_COMB_FILTER	Comb filter enable control
17	DrvADC_ENABLE_INT	ADC Interrupt Enable
18	DrvADC_DISABLE_INT	ADC Interrupt Disable
19	DrvADC_READ_INT_FLAG	Read ADC interrupt flag
20	DrvADC_CLEAR_INT_FLAG	Clear ADC interrupt flag
21	DrvADC_ENABLE	Enable ADC control
22	DrvADC_DISABLE	Disable ADC control
23	DrvADC_GetConversionData	Get the A/D conversion data

6.2 The block diagram of ADC

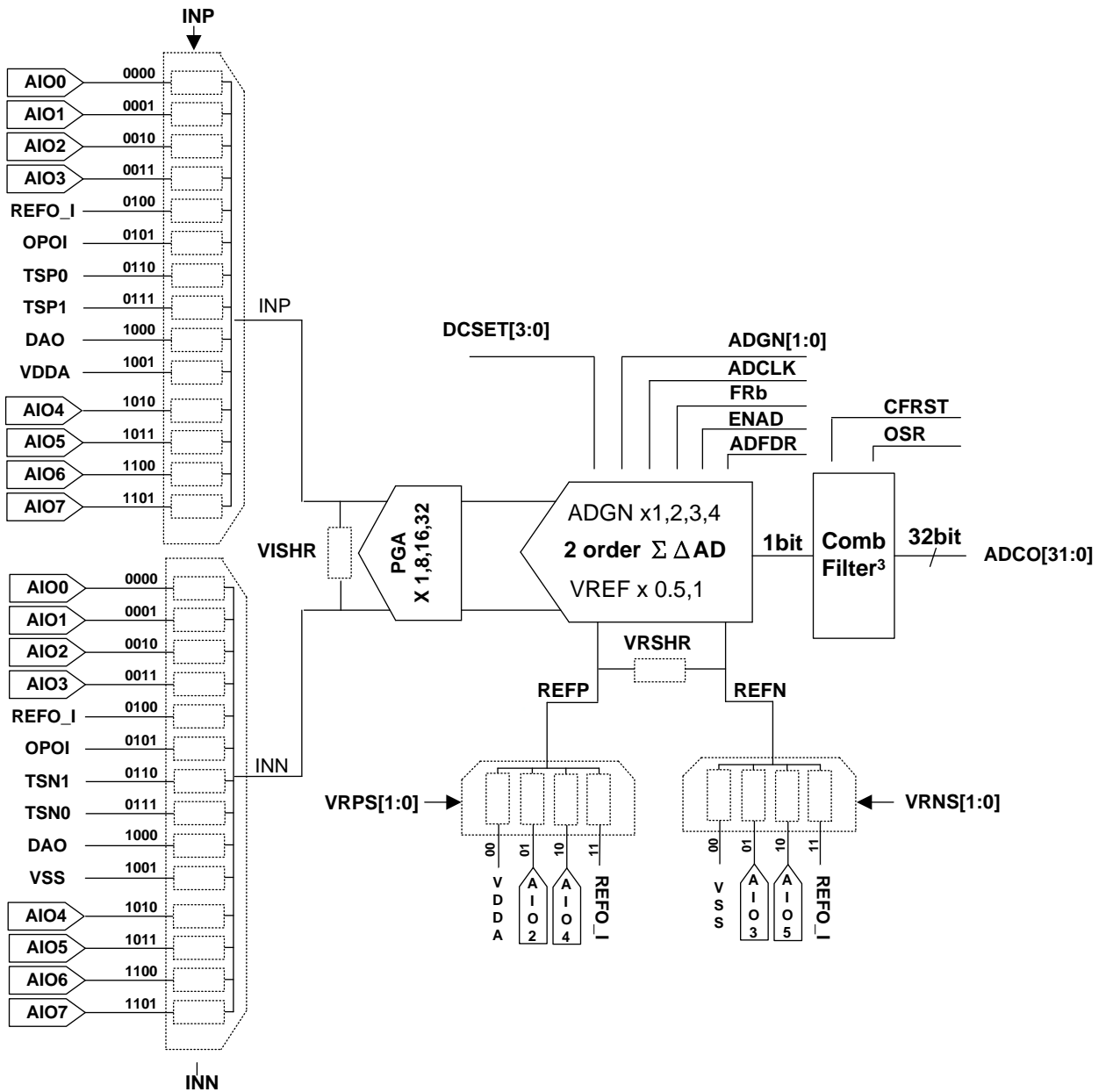

6.3 Type Definition

E_ADC_INPUT_CHANNEL

Enumeration Identifier	Value	Description
ADC_Input_AIO0	0	Signal input
ADC_Input_AIO1	1	Signal input
ADC_Input_AIO2	2	Signal input
ADC_Input_AIO3	3	Signal input
REFO_I	4	Signal input
OPOI	5	Signal input
TSP0	6	Signal input
TSP1	7	Signal input
DAO	8	Signal input
VDDA_VSSA	9	Signal input
ADC_Input_AIO4	10	Signal input
ADC_Input_AIO5	11	Signal input
ADC_Input_AIO6	12	Signal input
ADC_Input_AIO7	13	Signal input

E_ADC_REFV

Enumeration Identifier	Value	Description
External	0	External
Internal	1	Enable buffer and use internal source

E_ADC_PGA & E_ADC_ADGN

Enumeration Identifier	Value	Description
ADC_PGA_Disable	0	Disable PGA
ADC_Gain_8	1	Gain=8
ADC_Gain_16	3	Gain=16
ADC_Gain_32	7	Gain=32
ADC_ADGN_1	0	ADGN=1
ADC_ADGN_2	1	ADGN=2
ADC_ADGN_RESER	2	Reserve
ADC_ADGN_4	3	ADGN=4

E_ADC_SIGNAL_SHORT

Enumeration Identifier	Value	Description
OPEN	0	ADC signal input (positive and negative)open control
SHORT	1	ADC signal input(positive and negative)short control

E_ADC_VRPS_REF_VOLTAGE

Enumeration Identifier	Value	Description
VDDA	0	Reference voltage VDDA
AIO2	1	Reference voltage form AIO2
AIO4	2	Reference voltage form AIO4
REF_BUFFER_OUT	3	Reference voltage form REFO

E_ADC_VRNS_REF_VOLTAGE

Enumeration Identifier	Value	Description
------------------------	-------	-------------

VSSA	0	Reference voltage VSSA
AIO3	1	Reference voltage form AIO3
AIO5	2	Reference voltage form AIO5
REF_BUFFER_OUT	3	Reference voltage form REFO

6.4 Functions

6.4.1 DrvADC_POSITIVE_INPUT_CHANNEL

- **Prototype**

unsigned int DrvADC_PInputChannel (E_ADC_INPUT_Channel uINP);

- **Description**

Set the ADC positive input voltage source.

Configure the register 0x41104[7:4]

- **Parameters**

uINP [in] Specify the input channel. It could be 0~13

0:AIO0, 1:AIO1,
2:AIO2, 3:AIO3,
4:REFO_I, 5:OPOI,
6:TSP0, 7:TSP1,
8: DAO, 9:VDDA;
10:AIO4 11:AIO5
12:AIO6 13AIO7

- **Include**

Peripheral_lib/DrvADC.h

- **Return Value**

0: Operation successful

Other : Incorrect argument

- **Example**

```
/* Select the positive input voltage source form AIO0*/
```

```
DrvADC_PInputChannel (ADC_Input_AIO0);
```

6.4.2 DrvADC_NEGATIVE_INPUT_CHANNEL

- **Prototype**

unsigned int DrvADC_NInputChannel (E_ADC_INPUT_Channel uINN);

- **Description**

Set the ADC negative input voltage source.

Configure the register 0x41104[3:0]

- **Parameters**

uINN [in] Specify the input channel. It could be 0~13

0: AIO0,	1: AIO1,
2: AIO2,	3: AIO3,
4: REFO_I,	5: OPOI,
6: TSN0,	7: TSN1,
8: DAO,	9: VDDA;
10: AIO4	11: AIO5
12: AIO6	13: AIO7

● Include

Peripheral_lib/DrvADC.h

● Return Value

0: Operation successful

Other : Incorrect argument

● Example

```
/* Select the negative input voltage source form AIO0*/
```

```
DrvADC_NInputChannel (ADC_Input_AIO0);
```

6.4.3 DrvADC_INPUT_CHANNEL

● Prototype

```
unsigned int DrvADC_SetADCInputChannel (  
    E_ADC_INPUT_Channel uINP,  
    E_ADC_INPUT_Channel uINN  
);
```

● Description

Set the ADC input source.

Configure the register 0x41104[7:4] / 0x41104[3:0].

● Parameters

uINP [in] Specify the positive input channel. It could be 0~13

0: AIO0,	1: AIO1,
2: AIO2,	3: AIO3,
4: REFO_I,	5: OPOI,
6: TSP0,	7: TSP1,
8: DAO,	9: VDDA;
10: AIO4	11: AIO5
12: AIO6	13: AIO7

uINN [in] Specify the negative input channel. It could be 0~13

0: AIO0,	1: AIO1,
2: AIO2,	3: AIO3,

4: REFO_I,	5: OPOI,
6: TSN0,	7: TSN1,
8: DAO,	9: VDDA;
10: AIO4	11: AIO5
12: AIO6	13: AIO7

The positive input channel uses the same symbol as the negative input channel in C library.

{ADC_Input_AIO0, ADC_Input_AIO1, ADC_Input_AIO2, ADC_Input_AIO3,
REFO_I, OPOI, TPS0, TPS1, DAO, VDDA_VSS, ADC_Input_AIO4, ADC_Input_AIO5,
ADC_Input_AIO6, ADC_Input_AIO7}.

- **Include**

Peripheral_lib/DrvADC.h

- **Return Value**

0: Operation successful

Other : Incorrect argument

- **Example**

/* the following statement indicates that the external analog input is AIO0 and AIO1 input */

```
DrvADC_SetADCInputChannel(ADC_Input_AIO0, ADC_Input_AIO1);
```

6.4.4 DrvADC_INPUT_SWITCH

- **Prototype**

unsigned int DrvADC_InputSwitch (uVISHR)

- **Description**

ADC signal input (positive and negative) short control.

Configure the register 0x41100[21]

- **Parameter**

uVISHR[in] ADC input short switch.

0: PEN

1: SHORT

- **Include**

Peripheral_lib/DrvADC.h

- **Return Value**

0: Operation successful

Other : Incorrect argument

- **Example**

/* ADC input short */

```
DrvADC_InputSwitch (1);
```

6.4.5 DrvADC_REF_INPUT_SHORT_CONTROL

- **Prototype**

unsigned int DrvADC_RefInputShort (E_ADC_SIGNAL_SHORT uVrshr);

- **Description**

Set the ADC reference input (positive and negative) short control.

Configure the register 0x41100[20]

- **Parameters**

uVrshr [in] ADC reference input short control.

0 : ADC reference input (positive and negative)open control

1 : ADC reference input(positive and negative)short control

- **Include**

Peripheral_lib/DrvADC.h

- **Return Value**

0: Operation successful

Other : Incorrect argument

- **Example**

```
/* Set the ADC reference input short */
```

```
DrvADC_RefInputShort (SHORT);
```

6.4.6 DrvADC_PGA

- **Prototype**

unsigned int DrvADC_SetPGA (E_ADC_PGA uPGA);

- **Description**

Input signal gain for modulator.

Configure the register 0x41104[18:16]

- **Parameters**

uPGA [in] Specify the ADC PGA.

0: Gain=1

1: Gain=8

2: Reserved

3: Gain=16

4: Reserved

5: Reserved

6: Reserved

7: Gain=32

- **Include**

Peripheral_lib/DrvADC.h

- **Return Value**

0: Operation successful
Other : Incorrect argument

- **Example**

```
/* Set the gain of 8 */  
DrvADC_SetPGA(ADC_Gain_8);
```

6.4.7 DrvADC_AD_GAIN

- **Prototype**

unsigned int DrvADC_ADGain (uADgain);

- **Description**

Input signal gain for modulator.
Configure the register 0x41104[21:20]

- **Parameters**

uADgain [in] Specify the ADC ADGN.
0: Gain=1
1: Gain=2
3: Gain=4

- **Include**

Peripheral_lib/DrvADC.h

- **Return Value**

0: Operation successful
Other : Incorrect argument

- **Example**

```
/* Set the gain of 2 */  
DrvADC_ADGain (1);
```

6.4.8 DrvADC_GAIN

- **Prototype**

unsigned int DrvADC_Gain (E_ADC_PGA uPGA ,uADgain);

- **Description**

Input signal gain for modulator.
Configure the register 0X41104[18:16]/ 0X41104[21:20]

- **Parameters**

uPGA [in] Specify the ADC PGA.
0: Gain=1
1: Gain=8

- 2: Reserved
- 3: Gain=16
- 4: Reserved
- 5: Reserved
- 6: Reserved
- 7: Gain=32
- uADgain [in] Specify the ADC ADGN.
- 0: Gain=1
- 1: Gain=2
- 3: Gain=4

- **Include**

Peripheral_lib/DrvADC.h

- **Return Value**

- 0: Operation successful
- Other : Incorrect argument

- **Example**

```
/* Set the total gain of 128 */  
DrvADC_Gain (7,3);
```

6.4.9 DrvADC_SetADC_DC_OFFSET

- **Prototype**

unsigned int DrvADC_DCOffset (uDCOffset);

- **Description**

DC offset input voltage selection (VREF=REFP-REFN)
Configure the register 0x41104[27:24]

- **Parameters**

uDCoffice [in] Specify the ADC DCSET.

- 0 : 0 VREF
- 1 : +1/8 VREF
- 2 : +1/4 VREF
- 3 : +3/8 VREF
- 4 : +1/2 VREF
- 5 : +5/8 VREF
- 6 : +3/4 VREF
- 7 : +7/8 VREF
- 8 : 0 VREF
- 9 : -1/8 VREF
- 10 : -1/4 VREF

- 11 : -3/8 VREF
- 12 : -1/2 VREF
- 13 : -5/8 VREF
- 14 : -3/4 VREF
- 15 : -7/8 VREF

- **Include**

Peripheral_lib/DrvADC.h

- **Return Value**

0: Operation successful
Other : Incorrect argument

- **Example**

```
/* Set the DC offset of +1/8 voltage. */  
DrvADC_DCoffset (1);
```

6.4.10 DrvADC_SetADC_REFERENCE_VOLTAGE

- **Prototype**

```
unsigned int DrvADC_RefVoltage (  
    E_ADC_VRPS_REF_VOLTAGE uVrps,  
    E_ADC_VRNS_REF_VOLTAGE uVrns  
);
```

- **Description**

Set the ADC reference voltage.
Configure the register 0X41100[19:18] 及0X41100[17:16].

- **Parameters**

uVrps [in] Specify the ADC VRPS.
0 : Reference voltage VDDA
1 : Reference voltage form AIO2
2 : Reference voltage form AIO4
3 : Reference voltage form REFO
uVrns [in] Specify the ADC VRNS.
0 : Reference voltage VSSA
1 : Reference voltage form AIO2
2 : Reference voltage form AIO4
3 : Reference voltage form REFO

- **Include**

Peripheral_lib/DrvADC.h

- **Return Value**

0: Operation successful

Other : Incorrect argument

- **Example**

```
/* Set the ADC reference voltage.(VRPS=AIO2, VRNS=AIO3) */  
DrvADC_RefVoltage (AIO2, AIO3);
```

6.4.11 DrvADC_SetADC_FULL_REF_RANGE

- **Prototype**

```
unsigned int DrvADC_FullRefRange(uFullRange);
```

- **Description**

Set the ADC full reference range select.

Configure the register 0x41104[19]

- **Parameters**

uFullRange [in] Specify the VREF gain.

0: Full reference range input

1: 1/2 reference range input

- **Include**

Peripheral_lib/DrvADC.h

- **Return Value**

0: Operation successful

Other : Incorrect argument

- **Example**

```
/* Set the ADC full reference range input. */  
DrvADC_FullRefRange (0);
```

6.4.12 DrvADC_SetADC_OSR

- **Prototype**

```
unsigned int DrvADC_OSR (uADCOSR);
```

- **Description**

Set the ADC OSR.

Configure the register 0x41100[5:2]

- **Parameters**

uADCOSR [in] Specify the ADC OSR. (The following output rate is calculated when clock is 327680HZ)

0 : ÷32768 · Data Output Rate is 10sps

1 : ÷16384 · Data Output Rate is 20sps

2 : ÷8192 · Data Output Rate is 40sps

3 : ÷4096 · Data Output Rate is 80sps

- 4 : ÷2048 , Data Output Rate is 160sps
- 5 : ÷1024 , Data Output Rate is 320sps
- 6 : ÷512 , Data Output Rate is 640sps
- 7 : ÷256 , Data Output Rate is 1280sps
- 8 : ÷128 , Data Output Rate is 2560sps
- 9 : ÷64 , Data Output Rate is 5120sps
- 10 : ÷32 , Data Output Rate is 10240sps

- **Include**

Peripheral_lib/DrvADC.h

- **Return Value**

0: Operation successful
Other : Incorrect argument

- **Example**

```
/* Set the OSR of 8192 data rate 10sps. */  
DrvADC_OSR (2);
```

6.4.13 DrvADC_CLOCK_ENABLE

- **Prototype**

```
unsigned int DrvADC_ClkEnable(uADCD, uClkPH);
```

- **Description**

Enable ADC clock, set the clock divider, the ADC clock phase adjustment
Configure the register 0x4030C[7:4]

- **Parameters**

uADCD [in] Specify the ADC clock divider.

- 0 : ÷6
- 1 : ÷12
- 2 : ÷30
- 3 : ÷60

uClkPH [in]

- 0 : ADC clock rising edge of CPU clock low.
- 1 : ADC clock rising edge of CPU clock high.

- **Include**

Peripheral_lib/DrvADC.h

- **Return Value**

0: Operation successful
Other : Incorrect argument

- **Example**

```
/* Set the AD CD of ÷12 , ADC clock rising edge of CPU clock high. */  
DrvADC_ClkEnable(1,1);
```

6.4.14 DrvADC_CLOCK_DISABLE

- **Prototype**

```
void DrvADC_ClkDisable(void);
```

- **Description**

Disable ADC clock.

Configure the register 0x4030C[6]

- **Parameters**

None

- **Include**

Peripheral_lib/DrvADC.h

- **Return Value**

0: Operation successful

Other : Incorrect argument

- **Example**

```
/* Disable ADC clock. */  
DrvADC_ClkDisable();
```

6.4.15 DrvADC_FAST_CHOPPER

- **Prototype**

```
unsigned int DrvADC_FastChopper(uADFDR);
```

- **Description**

Fast chopper stable mode control.

Configure the register 0x41104[7:4]

- **Parameters**

uADFDR [in] Fast chopper stable mode control.

0 : Normal mode chopper frequency = ADCLK/128

1 : Fast mode chopper frequency = ADCLK/32

- **Include**

Peripheral_lib/DrvADC.h

- **Return Value**

0: Operation successful

Other : Incorrect argument

- **Example**

```
/* Select the normal mode. */  
DrvADC_FAST_CHOPPER (0);
```

6.4.16 DrvADC_COMB_FILTER

- **Prototype**

unsigned int DrvADC_CombFilter(uCFRST);

- **Description**

Comb filter enable control

Configure the register 0x41100[1]

- **Parameters**

uCFRST [in] Comb filter enable control

0: Reset

1: On

- **Include**

Peripheral_lib/DrvADC.h

- **Return Value**

0: Operation successful

Other : Incorrect argument

- **Example**

```
/* Open the comb filter. */
```

```
DrvADC_CombFilter(1); // reset the comb filter
```

```
DrvADC_CombFilter(1); // enable the comb filter
```

6.4.17 DrvADC_ENABLE_INT

- **Prototype**

void DrvADC_EnableInt (void)

- **Description**

ADC Interrupt Enable

Configure the register 0x40008 [16]

- **Parameter**

None

- **Include**

Peripheral_lib/DrvADC.h

- **Return Value**

None

- **Example**

```
/* Enable ADC interrupt */
```

```
DrvADC_EnableInt ();
```

6.4.18 DrvADC_DISABLE_INT

- **Prototype**

void DrvADC_DisableInt (void)

- **Description**

ADC Interrupt Disable

Configure the register 0x40008 [16]

- **Parameter**

None

- **Include**

Peripheral_lib/DrvADC.h

- **Return Value**

None

- **Example**

```
/* Disable ADC interrupt */  
DrvADC_DisableInt ();
```

6.4.19 DrvADC_READ_INT_FLAG

- **Prototype**

unsigned int DrvADC_ReadIntFlag (void)

- **Description**

Read ADC interrupt flag.

Read the register 0x40008 [0]

- **Parameter**

None

- **Include**

Peripheral_lib/DrvADC.h

- **Return Value**

0 : Interrupt flag is0

1 : Interrupt flag is1

>1: Invalid return value

- **Example**

```
/* Read ADC interrupt flag */  
uchar flag ; flag=DrvADC_ReadIntFlag ();
```

6.4.20 DrvADC_CLEAR_INT_FLAG

- **Prototype**

void DrvADC_ClearIntFlag (void)

- **Description**

Clear ADC interrupt flag.

Configure the register 0x40008[0]

- **Parameter**

None

- **Include**

Peripheral_lib/DrvADC.h

- **Return Value**

None

- **Example**

```
/* Clear ADC interrupt flag */  
DrvADC_ClearIntFlag ();
```

6.4.21 DrvADC_ENABLE

- **Prototype**

void DrvADC_Enable(void)

- **Description**

Enable ADC control

Configure the register 0x41100[0]

- **Parameters**

None

- **Include**

Peripheral_lib/DrvADC.h

- **Return Value**

None.

- **Example**

```
/* Enable ADC */  
DrvADC_Enable();
```

6.4.22 DrvADC_DISABLE

- **Prototype**

void DrvADC_Disable(void)

- **Description**

Disable ADC control

- **Parameters**

None

- **Include**

Peripheral_lib/DrvADC.h

- **Return Value**

None.

- **Example**

```
/* Disable ADC */  
DrvADC_Disable();
```

6.4.23 DrvADC_GetConversionData

- **Prototype**

unsigned int DrvADC_GetConversionData (void);

- **Description**

Get the A/D conversion data with signed.

Configure the register 0x41108[31:0]

- **Parameters**

None.

- **Include**

Peripheral_lib/DrvADC.h

- **Return Value**

Return the conversion data.

- **Example**

```
/* Get the conversion data */  
int adc_data ;  
adc_data=DrvADC_GetConversionDate();
```



7. SPI32 Driver

7.1 Introduction

The following functions are included in SPI Manager Section.

Item	Functions	Description
01	DrvSPI32_Open	Open SPI module
02	DrvSPI32_Close	Close SPI module
03	DrvSPI32_IsBusy	Check busy status
04	DrvSPI32_SetClockFreq	Configure the frequency of SPI clock
05	DrvSPI32_IsRXBufferFull	Check Rx buffer status
06	DrvSPI32_IsTxBufferFull	Check Tx buffer status
07	DrvSPI32_EnableRxInt	Enable the SPI Rx interrupt
08	DrvSPI32_EnableTxInt	Enable the SPI Tx interrupt
09	DrvSPI32_DisableRxInt	Disable the SPI Rx interrupt
10	DrvSPI32_DisableTxInt	Disable the SPI Tx interrupt
11	DrvSPI32_GetRxIntFlag	Get the SPI32 Rx interrupt flag
12	DrvSPI32_GetTxIntFlag	Get the SPI32 Tx interrupt flag
13	DrvSPI32_ClrIntRxFlag	Clear the SPI Rx interrupt flag
14	DrvSPI32_ClrIntTxFlag	Clear the SPI Tx interrupt flag
15	DrvSPI32_Read	Read data from SPIBUF registers
16	DrvSPI32_Write	Write data to SPIBUF register
17	DrvSPI32_Enable	Enable the SPI
18	DrvSPI32_BitLength	Set the SPI transfer Bit length
19	DrvSPI32_GetDCFlag	Get data loss flag of state
20	DrvSPI32_IsABFlag	Read the flag of received data deficient
21	DrvSPI32_IsOVFlag	Read the flag of SPI Bus Data too long
22	DrvSPI32_IsRxFlag	Read the flag of Rx Buffer Updata
23	DrvSPI32_SetEndian	Set the data transmitted from the MSB or LSB start
24	DrvSPI32_SetCS	Configure CS Polarity
25	DrvSPI32_DisableIO	Disable the SPI port to transmit
26	DrvSPI32_EnableIO	Enable and specify the SPI port to transmit

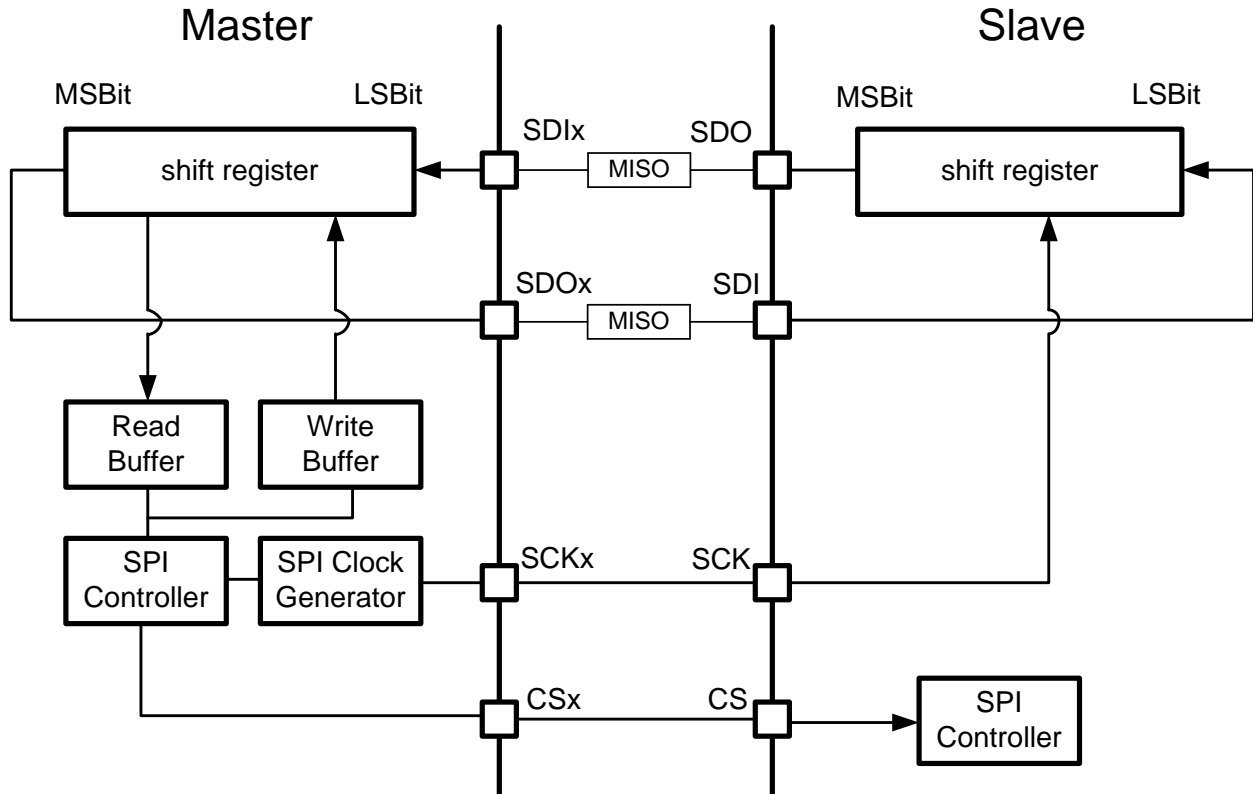
7.2 The block diagram of SPI



7.3 Type Definition

E_DRVSPi_MODE

Enumeration Identifier	Value	Description
E_DRVSPi_MASTER1	0	Master,4wire mode
E_DRVSPi_MASTER2	1	Master,3wire mode
E_DRVSPi_MASTER3	2	Master,TI mode
E_DRVSPi_SLAVE1	3	Slave,4wire mode
E_DRVSPi_SLAVE2	4	Slave,3wire mode
E_DRVSPi_SLAVE3	5	Slave,TI mode

E_DRVSPi_TRANS_TYPE

Enumeration Identifier	Value	Description
E_DRVSPi_TYPE0	0	SPI transfer type 0
E_DRVSPi_TYPE1	1	SPI transfer type 1
E_DRVSPi_TYPE2	2	SPI transfer type 2
E_DRVSPi_TYPE3	3	SPI transfer type 3

E_DRVSPi_ENDIAN

Enumeration Identifier	Value	Description
E_DRVSPi_LSB_FIRST	0	Send LSB first

E_DRVSPi_MSB_FIRST	1	Send MSB first
--------------------	---	----------------

E_DRVSPi_CS

Enumeration Identifier	Value	Description
E_DRVSPi_CSLow	0	CS0 low
E_DRVSPi_CSHigh	1	CS0 high

7.4 Functions

7.4.1 DrvSPi32_Open

- **Prototype**

```
unsigned int DrvSPi_Open(  
    E_DRVSPi_MODE uMode,  
    E_DRVSPi_TRANS_TYPE uType,  
    uOutputPin,  
    uClkDiv  
);
```

- **Description**

This function is used to open SPI module. It decides the SPI to work in master or slave mode, SPI bus timing, specified I / O port. Configure the register 0X4030C[3:0], 0X40844[6:4],0X40F00[3:1]

1. Setting the working mode
2. Set the CPHA, CPOL
3. Enable I/O port
4. Specify the output and input port
5. Enable SPI clock
6. Set the SPI Clock divider

- **Parameters**

uMode [in] Specify the operation mode

0 : Work in master mode interface 4-wire.

1 : Work in master mode interface 3-wire.

2 : Work in master mode interface TI mode.

3 : Work in slave mode interface 4-wire.

4 : Work in slave mode interface 3-wire.

5 : Work in slave mode interface TI mode.

uType [in] Transfer types, i.e. the bus timing. It could be 0~ 3.

0: Latch data on first edge of serial clock, clock idle state is low.(CPHA=0 CPOL=0)

1: Latch data on first edge of serial clock, clock idle state is high.(CPHA=0 CPOL=1)

- 2: Latch data on second edge of serial clock, clock idle state is low.(CPHA=1 CPOL=0)
- 3: Latch data on second edge of serial clock, clock idle state is high.(CPHA=1 CPOL=1)

uOutputPin [in] Specify the trasmission port

0 : Port1.0 =CS, Port1.1 =CK, Port1.2 = DI, Port1.3 =DO
1 : Port1.4 =CS, Port1.5 =CK, Port1.6 = DI, Port1.7 =DO
2 : Port2.0 =CS, Port2.1 =CK, Port2.2 = DI, Port2.3 =DO
3 : Port2.4 =CS, Port2.5 =CK, Port2.6 = DI, Port2.7 =DO
4 : Port8.0 =CS, Port8.1 =CK, Port8.2 = DI, Port8.3 =DO
5 : Port8.4 =CS, Port8.5 =CK, Port8.6 = DI, Port8.7 =DO
6 : Port9.0 =CS, Port9.1 =CK, Port9.2 = DI, Port9.3 =DO
7 : Port9.4 =CS, Port9.5 =CK, Port9.6 = DI, Port9.7 =DO

uClkDiv [in] Specify the clock divider

0 : =1
1 : =2
2 : =4
3 : =8
4 : =32
5 : =128
6 : =512
7 : =2048

● **Include**

Peripheral_lib/DrvSPI32.h

● **Return Value**

0: Operation successful
Other : Incorrect argument

● **Example**

```
/*Configure SPI as a master, SPI transfer type 1, Output Pin to select 1: Port1.4 =CS, Port1.5 =CK, Port1.6 = DI, Port1.7 =DO,Set SPI clock/512 */  
DrvSPI32_Open(E_DRVSPI_MASTER1, E_DRVSPI_TYPE1, 1,6);
```

7.4.2 DrvSPI32_Close

● **Prototype**

void DrvSPI32_Close (void);

● **Description**

Disable the SPI clock source divider(ENSD) and SPIEN and PTSPE.
Configure the register 0X40F00[0]=0, 0X4030C[3]=0,0X40844[4]=0

● **Parameters**

None

- **Include**

Peripheral_lib/DrvSPI32.h

- **Return Value**

None

- **Example**

```
/* Close the (SPI) */  
DrvSPI32_Close ();
```

7.4.3 DrvSPI32_IsBusy

- **Prototype**

```
unsigned int DrvSPI32_IsBusy( void );
```

- **Description**

Check the busy status of the SPI port.

- **Parameters**

None

- **Include**

Peripheral_lib/DrvSPI32.h

- **Return Value**

1: The SPI port is in busy.
0: The SPI port is not in busy.

- **Example**

```
/* Check the busy status */  
DrvSPI32_IsBusy ();
```

7.4.4 DrvSPI32_SetClockFreq

- **Prototype**

```
unsigned int DrvSPI32_SetClockFreq(unsigned int uCPUDV, unsigned int uTMRDV );
```

- **Description**

Configure the frequency of SPI clock. In master mode, the output frequency of serial clock is programmable.

Configure the register 0x4030C[3:0]

- **Parameters**

eCPUDV [in] Specify the MCU clock input divider.

0 : ÷1

1 : ÷2

eTMRDV [in] Specify the SPI clock source divider.

- 0 : ÷1
- 1 : ÷2
- 2 : ÷4
- 3 : ÷8
- 4 : ÷32
- 5 : ÷128
- 6 : ÷512
- 7 : ÷2048

- **Include**

Peripheral_lib/DrvSPI32.h

- **Return Value**

None

- **Example**

```
/* SPI clock rate is APCK/512 */  
DrvSPI32_SetClockFreq (1, 6);
```

7.4.5 DrvSPI32_IsRxBufferFull

- **Prototype**

```
unsigned int DrvSPI32_IsRxBufferFull(void );
```

- **Description**

Check Rx buffer status (only for data reception)

Configure the register 0x40F00[16]

- **Parameters**

None

- **Include**

Peripheral_lib/DrvSPI32.h

- **Return Value**

1: Rx buffer is full.

0: Rx buffer is not full.

- **Example**

```
/* Check the status of Rx buffer */  
DrvSPI32_IsRxBufferFull();
```

7.4.6 DrvSPI32_IsTxBufferFull

- **Prototype**

unsigned int DrvSPI32_IsTxBufferFull(void);

- **Description**

Check Tx buffer status (only for data reception)

Configure the register 0x40F00[16]

- **Parameters**

None

- **Include**

Peripheral_lib/DrvSPI32.h

- **Return Value**

1: Tx buffer is full.

0: Tx buffer is not full.

- **Example**

```
/* Check the status of Tx buffer */
```

```
DrvSPI32_IsTxBufferFull();
```

7.4.7 DrvSPI32_EnableRxInt

- **Prototype**

void DrvSPI32_EnableRxInt(void);

- **Description**

Enable the SPI Rx interrupt.

Configure the register 0x40000[16]

- **Parameters**

None

- **Include**

Peripheral_lib/DrvSPI32.h

- **Return Value**

None

- **Example**

```
/* Enable the SPI Rx interrupt */
```

```
DrvSPI32_EnableRxInt();
```

7.4.8 DrvSPI32_EnableTxInt

- **Prototype**

void DrvSPI32_EnableTxInt(void);

- **Description**

Enable the SPI Tx interrupt.

Configure the register 0x40000[17]

- **Parameters**

None

- **Include**

Peripheral_lib/DrvSPI32.h

- **Return Value**

None

- **Example**

```
/* Enable the SPI Tx interrupt */  
DrvSPI32_EnableTxInt();
```

7.4.9 DrvSPI32_DisableRxInt

- **Prototype**

void DrvSPI32_DisableRxInt(void);

- **Description**

Disable the SPI Rx interrupt.

Configure the register 0x40000[16]

- **Parameters**

None

- **Include**

Peripheral_lib/DrvSPI32.h

- **Return Value**

None

- **Example**

```
/* Disable the SPI Rx interrupt */  
DrvSPI32_DisableRxInt();
```

7.4.10 DrvSPI32_DisableTxInt

- **Prototype**

void DrvSPI32_DisableTxInt(void);

- **Description**

Disable the SPI Tx interrupt.

Configure the register 0x40000[17]

- **Parameters**

None

- **Include**

Peripheral_lib/DrvSPI32.h

- **Return Value**

None

- **Example**

```
/* Disable the SPI Tx interrupt */  
DrvSPI32_DisableTxInt();
```

7.4.11 DrvSPI32_GetRxIntFlag

- **Prototype**

unsigned int DrvSPI32_GetRxIntFlag ();

- **Description**

Get the SPI32 RX interrupt flag.

Read the register 0x40000.

- **Parameters**

None

- **Include**

Peripheral_lib/DrvSPI32.h

- **Return Value**

1: Interrupted

0: Normal

- **Example**

```
/* Get the SPI32 RX interrupt flag. */  
Unsigned char flag; flag=DrvSPI_GetRxIntFlag ();
```

7.4.12 DrvSPI32_GetTxIntFlag

- **Prototype**

unsigned int DrvSPI32_GetTxIntFlag ();

- **Description**

Get the SPI32 TX interrupt flag.

Read the register 0x40000[1]

- **Parameters**

None

- **Include**

Peripheral_lib/DrvSPI32.h

- **Return Value**

0: Interrupted

1: Normal

- **Example**

```
/* Get the SPI32 Tx interrupt flag. */
```

```
DrvSPI32_GetTxIntFlag ();
```

7.4.13 DrvSPI32_ClrIntRxFlag

- **Prototype**

void DrvSPI32_ClrIntRxFlag ();

- **Description**

Clear the SPI Rx interrupt flag.

Configure the register 0x40000[0]

- **Parameters**

None

- **Include**

Peripheral_lib/DrvSPI32.h

- **Return Value**

None

- **Example**

```
/* Clear the SPI Rx interrupt flag. */
```

```
DrvSPI32_ClrIntRxFlag ();
```

7.4.14 DrvSPI32_ClrIntTxFlag

- **Prototype**

```
void DrvSPI32_ClrIntTxFlag ();
```

- **Description**

Clear the SPI Tx interrupt flag.

Configure the register 0x40000[1]

- **Parameters**

None

- **Include**

Peripheral_lib/DrvSPI32.h

- **Return Value**

None

- **Example**

```
/* Clear the SPI Tx interrupt flag. */  
DrvSPI32_ClrIntTxFlag ();
```

7.4.15 DrvSPI32_Read

- **Prototype**

```
unsigned int DrvSPI32_Read();
```

- **Description**

Read data from SPI Rx buffer registers.

Read the register 0x40F08[31:0]

- **Parameters**

None

- **Include**

Peripheral_lib/DrvSPI32.h

- **Return Value**

The return value is SPI Rx buffer register data.

- **Example**

```
/*Data transmission: LSB First, 8bit*/  
Unsigned int data; data=DrvSPI32_Read ()>>24;  
/*Data transmission: MSB First, 8bit*/  
Unsigned int data; data=DrvSPI32_Read ();
```

7.4.16 DrvSPI32_Write

- **Prototype**

void DrvSPI32_Write (unsigned int uData);

- **Description**

Write data to SPI Tx buffer register.

Configure the register 0x40F0C[31:0]

- **Parameters**

uData [in]

Pre-sent data:0~0xFFFFFFFF

- **Include**

Peripheral_lib/DrvSPI32.h

- **Return Value**

None

- **Example**

*/*Data transmission: MSB First, 8bit Send 0x55*/*

DrvSPI32_Write (0x55<<24);

*/*Data transmission: LSB First, 8bit Send 0x55*/*

DrvSPI32_Write (0x55);

7.4.17 DrvSPI32_Enable

- **Prototype**

void DrvSPI32_Enable (void);

- **Description**

Enable the SPIEN.

Configure the register 0x40F00[0]

- **Parameters**

None

- **Include**

Peripheral_lib/DrvSPI32.h

- **Return Value**

None.

- **Example**

/ Enable the SPI */*

DrvSPI32_Enable ();

7.4.18 DrvSPI32_BitLength

- **Prototype**

void DrvSPI32_BitLength (unsigned int uData);

- **Description**

Set the SPI transfer Bit length.

Configure the register 0x40F04[4:0]

- **Parameters**

uData

Specify SPI data length. It could be 4~32

- **Include**

Peripheral_lib/DrvSPI32.h

- **Return Value**

None.

- **Example**

```
/* Set SPI transfer Bit length 8*/
```

```
DrvSPI32_BitLength(8);
```

7.4.19 DrvSPI32_GetDCFlag

- **Prototype**

unsigned int DrvSPI32_GetDCFlag(void);

- **Description**

Get data loss flag of state.

Read the register 0x40F00[18]

- **Parameters**

None

- **Include**

Peripheral_lib/DrvSPI32.h

- **Return Value**

0: Normal.

1: Rx buffer data is overwritten.

- **Example**

```
/* Check the status of DCF */
```

```
DrvSPI32_GetDCFlag();
```

7.4.20 DrvSPI32_IsABFlag

- **Prototype**

unsigned int DrvSPI32_IsABFlag(void);

- **Description**

Check whether the data deficient

Read the register 0x40F00[20]

- **Parameters**

None

- **Include**

Peripheral_lib/DrvSPI32.h

- **Return Value**

0: Normal.

1: SPI Bus receive data length is less than BL.

- **Example**

```
/* Check the status of ABF */
```

```
unsigned char flag; flag=DrvSPI32_IsABFlag();
```

7.4.21 DrvSPI32_IsOVFlag

- **Prototype**

unsigned int DrvSPI32_IsOVFlag(void);

- **Description**

Check whether the received data is too long

Read the register 0x40F00[21]

- **Parameters**

None

- **Include**

Peripheral_lib/DrvSPI32.h

- **Return Value**

0: Normal.

1: SPI Bus receive data length is greater than BL

- **Example**

```
/* Check the status of OVF */
```

```
Unsigned char flag; flag=DrvSPI32_IsOVFlag();
```

7.4.22 DrvSPI32_ IsRxFlag

- **Prototype**

unsigned int DrvSPI32_IsRxFlag(void);

- **Description**

Check whether the Rx buffer data in the update.

Read the register 0x40F00[22]

- **Parameters**

None

- **Include**

Peripheral_lib/DrvSPI32.h

- **Return Value**

0: Normal.

1: SPI buffer data update

- **Example**

```
/* Check the status of RxF */
```

```
Unsigned char flag; flag=DrvSPI32_IsRxFlag();
```

7.4.23 DrvSPI32_SetEndian

- **Prototype**

void DrvSPI32_SetEndian(E_DRVSPI_ENDIAN eEndian);

- **Description**

Set the data transfer from the MSB or LSB start

Configure the register 0x40F04[18]

- **Parameters**

eEndian [in]

1 : Send LSB first

0 : Send MSB first

- **Include**

Peripheral_lib/DrvSPI32.h

- **Return Value**

None

- **Example**

```
/* The transfer order is LSB first */
```

```
DrvSPI32_SetEndian(E_DRVSPI_LSB_FIRST);
```

7.4.24 DrvSPI32_SetCSO

- **Prototype**

```
void DrvSPI32_SetCSO(E_DRVSPI_CS eCS);
```

- **Description**

Set the CS signal simulator control bit.

Configure the register 0x40F04[20]

Note: The old function DrvSPI32_SetCS(E_DRVSPI_CS eCS) is the same operation as DrvSPI32_SetCSO(E_DRVSPI_CS eCS)

- **Parameters**

eCS[in]:

0: CS signal simulator works

1: CS signal simulator stands by

- **Include**

Peripheral_lib/DrvSPI32.h

- **Return Value**

None

- **Example**

```
/* Set low level is effective */
```

```
DrvSPI32_SetCSO(E_DRVSPI_CSLow);
```

7.4.25 DrvSPI32_DisableIO

- **Prototype**

```
void DrvSPI32_DisableIO(void);
```

- **Description**

Disable the SPI port to transmit

Configure the register 0x40844[4]

- **Parameters**

None

- **Include**

Peripheral_lib/DrvSPI32.h

- **Return Value**

None

- **Example**

```
/* Disable the SPI port to transmit */
```

```
DrvSPI32_DisableIO();
```

7.4.26 DrvSPI32_EnableIO

- **Prototype**

```
unsigned char DrvSPI32_EnableIO(uint32_t uOutputPin);
```

- **Description**

Enable and specify the SPI port to transmit

Configure the register 0X40844[6:5] / 0X40844[4]=1;

- **Parameters**

uOutputPin [in]: specify the port as SPI

0 : Port1.0 =CS, Port1.1 =CK, Port1.2 = DI, Port1.3 =DO

1 : Port1.4 =CS, Port1.5 =CK, Port1.6 = DI, Port1.7 =DO

2 : Port2.0 =CS, Port2.1 =CK, Port2.2 = DI, Port2.3 =DO

3 : Port2.4 =CS, Port2.5 =CK, Port2.6 = DI, Port2.7 =DO

4 : Port8.0 =CS, Port8.1 =CK, Port8.2 = DI, Port8.3 =DO

5 : Port8.4 =CS, Port8.5 =CK, Port8.6 = DI, Port8.7 =DO

6 : Port9.0 =CS, Port9.1 =CK, Port9.2 = DI, Port9.3 =DO

7 : Port9.4 =CS, Port9.5 =CK, Port9.6 = DI, Port9.7 =DO

- **Include**

Peripheral_lib/DrvSPI32.h

- **Return Value**

None

- **Example**

```
/* Enable the SPI port to transmit , select PT1.0~PT1.3*/
```

```
DrvSPI32_EnableIO(0);
```

8. UART Driver

8.1 Introduction

The Universal Asynchronous Receiver/Transmitter (UART) performs a serial-to-parallel conversion on data characters received from the peripheral such as MODEM, and a parallel-to-serial conversion on data characters received from the CPU. Details please refer to the section in the target chip specification titled UART.

Item	Functions	Description
01	DrvUART_Open	Set UART1 module
02	DrvUART_Close	Close UART1 module
03	DrvUART_EnableInt	Enable the UART1 interrupt
04	DrvUART_GetTxFlag	Get the TX interrupt flag of UART1
05	DrvUART_GetRxFlag	Get the RX interrupt flag of UART1
06	DrvUART_ClrTxFlag	Clear the TX interrupt flag of UART1
07	DrvUART_ClrRxFlag	Clear the RX interrupt flag of UART1
08	DrvUART_Read	Read data from RCREG of UART1
09	DrvUART_ClrABDOVF	Clear the RXABDF flag of UART1
10	DrvUART_Write	Write data to TXREG of UART1
11	DrvUART_ENABLE_WAKEUP	Enable wake-up mode of UART1
12	DrvUART_GETPERR	Get the PERR flag of UART1
13	DrvUART_GETFERR	Get the FERR flag of UART1
14	DrvUART_GETOERR	Get the OERR flag of UART1
15	DrvUART_GETABDOVF	Get the ABDOVF flag of UART1
16	DrvUART_ENABLE_AUTO_BAUDRATE	Enable Auto Baudrate of UART1
17	DrvUART_DISABLE_AUTO_BAUDRATE	Disable Auto Baudrate of UART1
18	DrvUART_CheckTRMT	Read the flag of Transmit Shift Register Status
19	DrvUART_ClkEnable	Enable and select the UART1 clock source
20	DrvUART_ClkDisable	Disable the UART1 `clock source
21	DrvUART_Enable	Enable the UART1 function
22	DrvUART_ConfigIO	Enable and select the IO port as UART1 communication port
23	DrvUART_TRStatus□	Read the RX/TX status of UART1
24	DrvUART_IntType□	Set the interrupt trigger method of UART1 RX and TX
25	DrvUART_DisableWakeUp□	Disable wake-up mode of UART1
26	DrvUART_GetNERR□	Get the RX Noise detected flag of UART1
27	DrvUART_ClrPERR□	Clear the Parity Error flag of UART1
28	DrvUART_ClrFERR□	Clear the RX Fram check error flag of UART1
29	DrvUART_ClrOERR□	Clear the RX Buffer over run error flag of UART1
30	DrvUART_ClrNERR□	Clear the RX Noise detected flag of UART1
31	DrvUART2_Open□	Set UART2 module
32	DrvUART2_Enable□	Enable the UART2 function
33	DrvUART2_Close□	Disable the UART2 function
34	DrvUART2_EnableInt□	Enable the UART2 TX or RX interrupt.
35	DrvUART2_IntType□	Set the interrupt trigger method of UART2 RX and TX
36	DrvUART2_GetTxFlag□	Get the Tx interrupt flag of UART2
37	DrvUART2_GetRxFlag□	Get the Rx interrupt flag of UART2
38	DrvUART2_ClrTxFlag□	Clear the Tx interrupt flag of UART2
39	DrvUART2_ClrRxFlag□	Clear the Rx interrupt flag of UART2

40	DrvUART2_Read□	Read data received from UART2
41	DrvUART2_Write□	Write data to TXREG register of UART2
42	DrvUART2_EnableWakeUp□	Enable wake-up mode of UART2
43	DrvUART2_DisableWakeUp□	Disable wake-up mode of UART2
44	DrvUART2_Enable_AutoBaudrate□	Enable Auto Baudrate of UART2
45	DrvUART2_Disable_AutoBaudrate□	Disable Auto Baudrate of UART2
46	DrvUART2_GetPERR□	Get the Parity Error flag of UART2
47	DrvUART2_GetFERR□	Get the FERR flag of UART2
48	DrvUART2_GetOERR□	Get the OERR flag of UART2
49	DrvUART2_GetNERR□	Get the RX Noise detected flag of UART2
50	DrvUART2_ClrPERR□	Clear the Parity Error flag of UART2
51	DrvUART2_ClrFERR□	Clear the RX Fram check error flag of UART2
52	DrvUART2_ClrOERR□	Clear the RX Buffer over run error flag of UART2
53	DrvUART2_ClrNERR□	Clear the RX Noise detected flag of UART2
54	DrvUART2_GetABDOVF□	Get the RXABDF flag of UART2
55	DrvUART2_ClrABDOVF□	Clear the RXABDF flag
56	DrvUART2_TRStatus□	Read the RX and TX status of UART2
57	DrvUART2_CheckTRMT□	Read the UART2 flag of Transmit Shift Register Status (TXBF)
58	DrvUART2_ClkEnable□	Enable and select the UART2 clock source
59	DrvUART2_ClkDisable□	Disable the UART2 clock source
60	DrvUART2_ConfigIO	Enable and select the IO port as UART2 communication port

8.2 The block diagram of UART

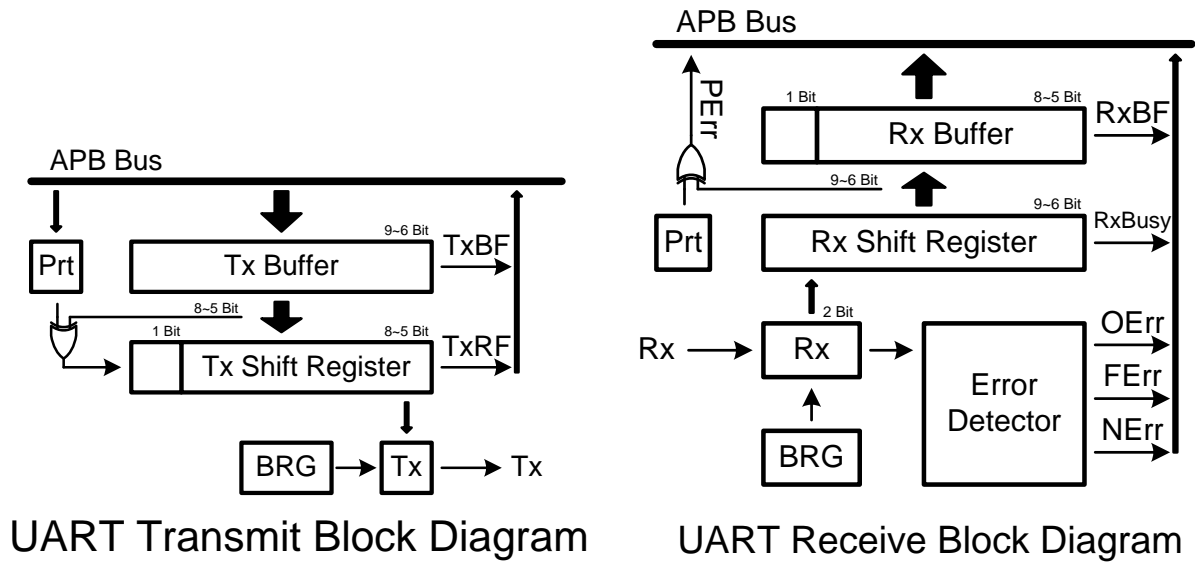

8.3 Type Definition

E_DATABITS_SETTINGS

Enumeration identifier	Value	Description
DRVUART_DATABITS_6	0x0	Word length select: Character length is 6 bits.
DRVUART_DATABITS_7	0x1	Word length select: Character length is 7 bits.
DRVUART_DATABITS_8	0x2	Word length select: Character length is 8 bits.
DRVUART_DATABITS_9	0x3	Word length select: Character length is 9 bits.

E_STOPBITS_SETTINGS

Enumeration identifier	Value	Description
DRVUART_STOPBITS_05	0x0	StopBits length selec:0.5 bits
DRVUART_STOPBITS_1	0x1	StopBits length selec:1 bits.
DRVUART_STOPBITS_15	0x2	StopBits length selec:1.5 bits
DRVUART_STOPBITS_2	0x3	StopBits length selec:2 bits.

E_PARITY_SETTINGS

Enumeration identifier	Value	Description
DRVUART_PARITY_NONE	0x0	None parity
DRVUART_PARITY_ODD	0x1	Odd parity enable
DRVUART_PARITY_EVEN	0x2	Even parity enable

E_BAUD_RATE_SETTINGS

Enumeration identifier	Value	Description
B1200	0x0	Baud rate=1200
B2400	0x1	Baud rate=2400
B4800	0x2	Baud rate=4800
B9600	0x3	Baud rate=9600
B14400	0x4	Baud rate=14400
B19200	0x5	Baud rate=19200
B38400	0x6	Baud rate=38400

E_UART_ERROR_MESSAGE

Enumeration identifier	Value	Description
E_UART_ERR_CLOCK	0x2	CLOCK Parameter input error
E_UART_ERR_BAUDRATE	0x3	Baud rate Parameter input error
E_UART_ERR_PARITY	0x4	Parity Parameter input error
E_UART_ERR_DATABIT	0x5	Data bit Parameter input error
E_UART_ERR_STOPBIT	0x6	StopBits length setting error
E_UART_ERR_OUTPIN	0x7	Output pin Parameter input error

8.4 Functions

8.4.1 DrvUART_Open

- **Prototype**

```

unsigned int DrvUART_Open (
                float          uClock
    E_RAUD_RATE_SETTINGS    uBaudRate ,
    E_PARITY_SETTINGS       uParity,
    E_DATABITS_SETTINGS    uDataBits,
    unsigned int            uStopBits,
    unsigned int            uOutputPin
);
    
```

- **Description**

Select the frequency value to used, to automatically calculate the value fill BRFRH: BRGRL, according to input the required baud rate value, UART1 with bit set, set the UART data-bit, Stop-bit, set the UART output pin

Configure the register 0X40E00[7:4], 0X40E00[2]=1, 0X40E00[0]=1 / 0X40E04[1:0] , 0X40E08[15:0], 0X40844[3:0].

- **Parameter**

uClock	Type oscillator frequency in MHz Unit
uBaudRate [in]	Type baud rate
uParity [in]	NONE/EVEN/ODD parity
It could be	
0	: None parity
1	: Even parity
2	: Odd parity.
uDataBits[in]:	data bit setting
It could be	
0	: 6 data bits.
1	: 7 data bits.
2	: 8 data bits
3	: 9 data bits
uStopBits[in] :	stop bit setting
0:	0.5 Bit
1:	1 Bit
2:	1.5 Bit
3:	2 Bit
uOutputPin [in]	

- 0 : Port 1.0 =TX, Port 1.1 =RX
- 1 : Port 1.4 =TX, Port 1.5 =RX
- 2 : Port 2.0 =TX, Port 2.1 =RX
- 3 : Port 2.4 =TX, Port 2.5 =RX
- 4 : Port 8.0 =TX, Port 8.1 =RX
- 5 : Port 8.4 =TX, Port 8.5 =RX
- 6 : Port 9.0 =TX, Port 9.1 =RX
- 7 : Port 9.4 =TX, Port 9.5 =RX

- **Include**

Peripheral_lib/DrvUART.h

- **Return Value**

- 0: Success.
- 2 : Wrong clock setting
- 3 : Wrong baud rate setting
- 4: Wrong party setting
- 5: Wrong Data bit setting
- 6:Wrong Stop bit setting
- 7: Wrong output pin setting

- **Example**

```
/* Set UART under 115200bps, 8 data bits ,1 stop bit, and none parity. PT1.4/PT1.5 used as interface*/  
DrvUART_Open (4,115200, DRVUART_PARITY_NONE ,DRVUART_DATABITS_8,1,2);
```

8.4.2 DrvUART_Close

- **Prototype**

```
void DrvUART_Close (void );
```

- **Description**

Disable uart

Clear the register 0X40E00[2]=0, 0X40E00[0]=0

- **Parameter**

None

- **Include**

Peripheral_lib/DrvUART.h

- **Return Value**

None

- **Example**

```
/* Close UART */  
DrvUART_Close ();
```

8.4.3 DrvUART_ EnableInt

- **Prototype**

unsigned int DrvUART_EnableInt(unsigned int uTXIE, unsigned int uRXIE);

- **Description**

Enable the UART1 TX or RX interrupt.

Configure the register 0x40000[19:18]

- **Parameters**

uTXIE [in] UART1 Tx Interrupt

0 : Disable

1 : Enable

uRXIE [in] UART1 Rx Interrupt

0 : Disable

1 : Enable

- **Include**

Peripheral_lib/DrvUART.h

- **Return Value**

0: Operation successful

Other : Incorrect argument

- **Example**

```
/* Enable the UART1 TX and RX interrupt */
```

```
DrvUART_EnableInt(1,1);
```

8.4.4 DrvUART_GetTxFlag

- **Prototype**

unsigned int DrvUART_GetTxFlag ();

- **Description**

Get the Tx interrupt flag of UART1.

Configure the register 0x40000[3]

- **Parameters**

None

- **Include**

Peripheral_lib/DrvUART.h

- **Return Value**

1: Interrupted

0: Normal

- **Example**

```
/* Get the Tx interrupt flag. */  
DrvUART_GetTxFlag();
```

8.4.5 DrvUART_GetRxFlag

- **Prototype**

```
unsigned int DrvUART_GetRxFlag ();
```

- **Description**

Get the Rx interrupt flag of UART1.
Configure the register 0x40000[2]

- **Parameters**

None

- **Include**

Peripheral_lib/DrvUART.h

- **Return Value**

0: Operation successful
Other : Incorrect argument

- **Example**

```
/* Get the Rx interrupt flag. */  
unsigned char flag; flag=DrvUART_GetRxFlag ();
```

8.4.6 DrvUART_ClrTxFlag

- **Prototype**

```
void DrvUART_ClrTxFlag ();
```

- **Description**

Clear the Tx interrupt flag of UART1.
Configure the register 0x40000[3]

- **Parameters**

None

- **Include**

Peripheral_lib/DrvUART.h

- **Return Value**

None

- **Example**

```
/* Clear the Tx interrupt flag. */  
DrvUART_ClrTxFlag ();
```

8.4.7 DrvUART_ClrRxFlag

- **Prototype**

void DrvUART_ClrRxFlag ();

- **Description**

Clear the Rx interrupt flag of UART1.

Configure the register 0x40000[2]

- **Parameters**

None

- **Include**

Peripheral_lib/DrvUART.h

- **Return Value**

None

- **Example**

```
/* Clear the Rx interrupt flag. */
```

```
DrvUART_ClrRxFlag ();
```

8.4.8 DrvUART_Read

- **Prototype**

unsigned int DrvUART_Read();

- **Description**

Read data received from UART1.

Read the register 0X40E0C[7:0]

- **Parameters**

None

- **Include**

Peripheral_lib/DrvUART.h

- **Return Value**

The return value is RCREG register data.

- **Example**

```
/* Read the RCREG register data. */
```

```
unsigned int rx_data; rx_data=DrvUART_Read ();
```

8.4.9 DrvUART_ClrABDOVF

- **Prototype**

unsigned int DrvUART_ClrABDOVF(void)

- **Description**

Clear the RXABDF flag of UART1.
Configure the register 0X40E04[4]

- **Parameters**

None

- **Include**

Peripheral_lib/DrvUART.h

- **Return Value**

None

- **Example**

```
/* Clear the RXABDF flag */  
DrvUART_ClrABDOVF();
```

8.4.10 DrvUART_Write

- **Prototype**

void DrvUART_Write(unsigned int uData);

- **Description**

Write data to TXREG register of UART1.
Configure the register 0x40E0C[24:16]

- **Parameters**

uData [in]
data to be sent

- **Include**

Peripheral_lib/DrvUART.h

- **Return Value**

None

- **Example**

```
/* using UART1 to send one byte 0x55 */  
DrvUART_Write (0x55);
```

8.4.11 DrvUART_ENABLE_WAKEUP

- **Prototype**

void DrvUART_EnableWakeUp();

- **Description**

Enable wake-up mode of UART1

Configure the register 0x40E04[2]=1

- **Parameters**

None

- **Include**

Peripheral_lib/DrvUART.h

- **Return Value**

None

- **Example**

```
/* Enable wake up. */
```

```
DrvUART_EnableWakeUp ();
```

8.4.12 DrvUART_GET_PERR

- **Prototype**

```
unsigned int DrvUART_GetPERR();
```

- **Description**

Get the Parity Error flag of UART1.

Configure the register 0x40E00[20]

- **Parameters**

None

- **Include**

Peripheral_lib/DrvUART.h

- **Return Value**

1 : Parity error

0 : No parity error

- **Example**

```
/* Get the PERR flag. */
```

```
unsigned char flag; flag=DrvUART_GetPERR ();
```

8.4.13 DrvUART_GET_FERR

- **Prototype**

```
unsigned int DrvUART_GetFERR();
```

- **Description**

Get the FERR flag of UART1.

Configure the register 0x40E00[21]

- **Parameters**

None

- **Include**

Peripheral_lib/DrvUART.h

- **Return Value**

1 : Framing error

0 : No framing error

- **Example**

```
/* Get the FERR flag. */
```

```
unsigned char flag ; flag=DrvUART_GetFERR ();
```

8.4.14 DrvUART_GET_OERR

- **Prototype**

```
unsigned int DrvUART_GetOERR();
```

- **Description**

Get the OERR flag of UART1.

Configure the register 0x40E00[23]

- **Parameters**

None

- **Include**

Peripheral_lib/DrvUART.h

- **Return Value**

1 : Overrun error

0 : No overrun error

- **Example**

```
/* Get the OERR flag. */
```

```
unsigned char flag ; flag=DrvUART_GetOERR();
```

8.4.15 DrvUART_GETABDOVF

- **Prototype**

unsigned int DrvUART_GetABDOVF();

- **Description**

Get the RXABDF flag of UART1.

Configure the register 0x40E04[4]

- **Parameters**

None

- **Include**

Peripheral_lib/DrvUART.h

- **Return Value**

1 : A BRG rollover has occurred during Auto-Baud Rate Detect mode

0 : No BRG rollover has occurred

- **Example**

```
/* Get the RXABDF flag. */
```

```
unsigned char flag ; flag=DrvUART_GetABDOVF();
```

8.4.16 DrvUART_ENABLE_AUTO_BAUDRATE

- **Prototype**

void DrvUART_Enable_AutoBaudrate ();

- **Description**

Enable Auto Baudrate of UART1

Configure the register 0x40E04[3]=1

- **Parameters**

None

- **Include**

Peripheral_lib/DrvUART.h

- **Return Value**

None

- **Example**

```
/* Enable Auto Baudrate */
```

```
DrvUART_Enable_AutoBaudrate ();
```

8.4.17 DrvUART_DISABLE_AUTO_BAUDRATE

- **Prototype**

void DrvUART_Disable_AutoBaudrate ();

- **Description**

Disable Auto Baudrate of UART1
Configure the register 0x40E04[3]

- **Parameters**

None

- **Include**

Peripheral_lib/DrvUART.h

- **Return Value**

None

- **Example**

```
/* Enable Auto Baudrate */  
DrvUART_Disable_AutoBaudrate ();
```

8.4.18 DrvUART_CheckTRMT

- **Prototype**

unsigned int DrvUART_CheckTRMT(void)

- **Description**

Read the UART1 flag of Transmit Shift Register Status(TXBF).
Read the register 0x40E00[18]

- **Parameters**

None

- **Include**

Peripheral_lib/DrvUART.h

- **Return Value**

0: Transmit Shift Register empty
1: Transmit Shift Register full

- **Example**

```
/* Read the flag of Transmit Shift Register Status */  
DrvUART_Write(data) ;  
While(DrvUART_CheckTRMT ()) ;//wait until TXBF=0
```

8.4.19 DrvUART_ClkEnable

- **Prototype**

unsigned int DrvUART_ClkEnable(unsigned int uclk,unsigned int uprescale)

- **Description**

Enable and select the UART1 clock source . Specify the clock source divider
Configure the register 0X40308[21 :16]

- **Parameters**

uclk[in] EUART clock source

0 : External high speed oscillator

1 : Internal high speed oscillator

Uprescale[in] : the clock source divider

0000 EUART CLOCK SOURCE/1	1000 EUART CLOCK SOURCE/256
0001 EUART CLOCK SOURCE/2	1001 EUART CLOCK SOURCE/512
0010 EUART CLOCK SOURCE/4	1010 EUART CLOCK SOURCE/1024
0011 EUART CLOCK SOURCE/8	1011 EUART CLOCK SOURCE/2048
0100 EUART CLOCK SOURCE/16	1100 EUART CLOCK SOURCE/4096
0101 EUART CLOCK SOURCE/32	1101 EUART CLOCK SOURCE/8192
0110 EUART CLOCK SOURCE/64	1110 EUART CLOCK SOURCE/16384
0111 EUART CLOCK SOURCE/128	1111 EUART CLOCK SOURCE/32768

- **Include**

Peripheral_lib/DrvUART.h

- **Return Value**

0: Operation successful

Other : Incorrect argument

- **Example**

```
/* select the external clock source, divider:clk/1 */  
DrvUART_ClkEnable (0,0);
```

8.4.20 DrvUART_ClkDisable

- **Prototype**

void DrvUART_ClkDisable(void) ;

- **Description**

Disable the UART1 clock source.

Configure the register 0X40308 [20]=0

- **Parameters**

None

- **Include**

Peripheral_lib/DrvUART.h

- **Return Value**

None

- **Example**

```
/* Disable the UART1 clock source */  
DrvUART_ClkDisable();
```

8.4.21 DrvUART_Enable

- **Prototype**

```
void DrvUART_Enable(void);
```

- **Description**

Enable the UART1 function

Configure the register 0X40E00[2]=1, 0X40E00[0]=1

- **Parameters**

None

- **Include**

Peripheral_lib/DrvUART.h

- **Return Value**

None

- **Example**

```
/* Enable the UART1 clock source */  
DrvUART_Enable();
```

8.4.22 DrvUART_ConfigIO

- **Prototype**

```
unsigned char DrvUART_ConfigIO(unsigned char ioen, unsigned int uOutputPin);
```

- **Description**

Enable and select the IO port as UART1 communication port

Configure the register 0X40844[3:0]

- **Parameters**

ioen[in] : EURAT1 input/output to port enable control

0: disable

1: enable

uoutputPin[in] : select the UART1 communication port

0 : Port 1.0 =TX, Port 1.1 =RX

1 : Port 1.4 =TX, Port 1.5 =RX

2 : Port 2.0 =TX, Port 2.1 =RX

3 : Port 2.4 =TX, Port 2.5 =RX

- 4 : Port 8.0 =TX, Port 8.1 =RX
- 5 : Port 8.4 =TX, Port 8.5 =RX
- 6 : Port 9.0 =TX, Port 9.1 =RX
- 7 : Port 9.4 =TX, Port 9.5 =RX

- **Include**

Peripheral_lib/DrvUART.h

- **Return Value**

- 0: Operation successful
- Other : Incorrect argument

- **Example**

```
/* enable and select PT2.0/PT2.1 as UART port*/  
DrvUART_ConfigIO(1,2);
```

8.4.23 DrvUART_TRStatus

- **Prototype**

unsigned int DrvUART_TRStatus(unsigned int uMode)

- **Description**

Read the RX and TX status of UART1.
Read the register 0x40E00[19:16]

- **Parameters**

uMode[in]
0 RXBF; 1 RXBUSY; 2 TXBF; 3 TXBUSY

- **Include**

Peripheral_lib/DrvUART.h

- **Return Value**

0: idle; 1: Busy (for TXBUSY and RXBUSY)
0: empty; 1: full (for TXBF and RXBF)

- **Example**

```
/* Get the TXBF flag. */  
DrvUART_Write(data) ;  
While(DrvUART_TRStatus (2)) ;//wait until TXBF=0
```

8.4.24 DrvUART_IntType

- **Prototype**

unsigned int DrvUART_IntType(unsigned int uTXIT, unsigned int uRXIT)

- **Description**

Set the interrupt trigger method of UART1 RX and TX .

Configure the register 0X40E00[1]/ 0X40E00[3]

- **Parameters**

uTXIT [in] the interrupt trigger method of TX

0 : Send out the interrupt when the Tx Data Buffer is idle, and the interrupt disappears after the data are written in.

1 : Sent out the interrupt after one piece of data is transmitted by the Tx

uRXIT[in] the interrupt trigger method of RX

0 : Send out the interrupt when the Rx Data Buffer has data, and the interrupt disappears after the data are read.

1 : Send out the interrupt after one piece of data is received by the Rx.

- **Include**

Peripheral_lib/DrvUART.h

- **Return Value**

0: Operation successful

Other : Incorrect argument

- **Example**

```
/* Send out the interrupt when the Tx Data Buffer is idle and the Rx Data Buffer has data */  
DrvUART_IntType(0, 0);
```

8.4.25 DrvUART_DISABLE_WAKEUP

- **Prototype**

```
void DrvUART_DisableWakeUp();
```

- **Description**

Disable wake-up mode of UART1

Configure the register 0x40E04[2]=0

- **Parameters**

None

- **Include**

Peripheral_lib/DrvUART.h

- **Return Value**

None

- **Example**

```
/* Disable wake up. */  
DrvUART_DisableWakeUp ();
```

8.4.26 DrvUART_GET_NERR

- **Prototype**

```
unsigned int DrvUART_GetNERR();
```

- **Description**

Get the RX Noise detected flag of UART1.

Read the register 0x40E00[22]

- **Parameters**

None

- **Include**

Peripheral_lib/DrvUART.h

- **Return Value**

1 : Noise detected

0 : Normal

- **Example**

```
/* Get the NERR flag. */
```

```
unsigned char flag; flag=DrvUART_GetNERR ();
```

8.4.27 DrvUART_ClrPERR

- **Prototype**

```
unsigned int DrvUART_ClrPERR();
```

- **Description**

Clear the Parity Error flag of UART1.

Configure the register 0x40E00[20]=0

- **Parameters**

None

- **Include**

Peripheral_lib/DrvUART.h

- **Return Value**

None

- **Example**

```
/* clear the PERR flag. */
```

```
DrvUART_ClrPERR ();
```

8.4.28 DrvUART_ClrFERR

- **Prototype**

```
unsigned int DrvUART_ClrFERR();
```

- **Description**

Clear the RX Fram check error flag of UART1.

Configure the register 0x40E00[21]=0

- **Parameters**

None

- **Include**

Peripheral_lib/DrvUART.h

- **Return Value**

None

- **Example**

```
/* clear the FERR flag. */  
DrvUART_ClrFERR ();
```

8.4.29 DrvUART_ClrOERR

- **Prototype**

```
unsigned int DrvUART_ClrOERR();
```

- **Description**

Clear the RX Buffer over run error flag of UART1.

Configure the register 0x40E00[23]=0

- **Parameters**

None

- **Include**

Peripheral_lib/DrvUART.h

- **Return Value**

None

- **Example**

```
/* clear the OERR flag. */  
DrvUART_ClrOERR ();
```

8.4.30 DrvUART_ClrNERR

- **Prototype**

```
unsigned int DrvUART_ClrNERR();
```

- **Description**

Clear the RX Noise detected flag of UART1.

Configure the register 0x40E00[22]=0

- **Parameters**

None

- **Include**

Peripheral_lib/DrvUART.h

- **Return Value**

None

- **Example**

```
/* clear the NERR flag. */  
DrvUART_ClrNERR ();
```

8.4.31 DrvUART2_Open

- **Prototype**

```
unsigned int DrvUART2_Open (  
    float    uClock  
    E_RAUD_RATE_SETTINGS  uBaudRate ,  
    E_PARITY_SETTINGS     uParity,  
    E_DATABITS_SETTINGS   uDataBits,  
    unsigned int          uStopBits,  
    unsigned int          uOutputPin  
);
```

- **Description**

Select the frequency value to used, to automatically calculate the value fill BRFRH: BRGRL, according to input the required baud rate value, UART2 with bit set, set the UART2 data-bit, Stop-bit, set the UART output pin

Configure the register 0X40E10[7:4], 0X40E10[2]=1, 0X40E10[0]=1 / 0X40E14[1:0];
0X40E18[15:0]; 0X4084C[3:0].

- **Parameter**

uClock	Type oscillator frequency in MHz Unit
uBaudRate [in]	Type baud rate
uParity [in]	NONE/EVEN/ODD parity
It could be	
0	: None parity
1	: Even parity
2	: Odd parity.
uDataBits[in]:	data bit setting
It could be	
0	: 6 data bits.
1	: 7 data bits.
2	: 8 data bits
3	: 9 data bits
uStopBits[in] :	stop bit setting

0: 0.5 Bit 1: 1 Bit

2: 1.5 Bit 3: 2 Bit

uOutputPin [in]

0 : Port 1.2 =TX2, Port 1.3 =RX2

1 : Port 1.6 =TX2, Port 1.7 =RX2

2 : Port 2.2 =TX2, Port 2.3 =RX2

3 : Port 2.6 =TX2, Port 2.7 =RX2

4 : Port 8.2 =TX2, Port 8.3 =RX2

5 : Port 8.6 =TX2, Port 8.7 =RX2

6 : Port 9.2 =TX2, Port 9.3 =RX2

7 : Port 9.6 =TX2, Port 9.7 =RX2

- **Include**

Peripheral_lib/DrvUART.h

- **Return Value**

0: Success.

2 : Wrong clock setting

3 : Wrong baud rate setting

4: Wrong parity setting

5: Wrong Data bit setting

6:Wrong Stop bit setting

7: Wrong output pin setting

- **Example**

/* Set UART2 under 115200bps, 8 data bits ,1 stop bit, and none parity. PT1.6/PT1.7 used as interface*/

DrvUART2_Open (4,115200, DRVUART_PARITY_NONE ,DRVUART_DATABITS_8,1,2);

8.4.32 DrvUART2_Enable

- **Prototype**

void DrvUART2_Enable(void) ;

- **Description**

Enable the UART2 function

Configure the register 0X40E10[2]=1. 0X40E10[0]=1

- **Parameters**

None

- **Include**

Peripheral_lib/DrvUART.h

- **Return Value**

None

- **Example**

```
/* Enable the UART2 */  
DrvUART2_Enable();
```

8.4.33 DrvUART2_Close

- **Prototype**

```
void DrvUART2_Close (void );
```

- **Description**

Disable UART2

Clear the register 0X40E10[2]=0, 0X40E10[0]=0

- **Parameter**

None

- **Include**

Peripheral_lib/DrvUART.h

- **Return Value**

None

- **Example**

```
/* Close UART2 */  
DrvUART2_Close ();
```

8.4.34 DrvUART2_ EnableInt

- **Prototype**

```
unsigned int DrvUART2_ EnableInt(unsigned int uTXIE, unsigned int uRXIE);
```

- **Description**

Enable the UART2 TX or RX interrupt.

Configure the register 0x40018[19:18]

- **Parameters**

uTXIE [in] UART2 Tx Interrupt

0 : Disable

1 : Enable

uRXIE [in] UART2 Rx Interrupt

0 : Disable

1 : Enable

- **Include**

Peripheral_lib/DrvUART.h

- **Return Value**

0: Operation successful
Other : Incorrect argument

● Example

```
/* Enable the UART2 TX and RX interrupt */  
DrvUART2_IntType(0,0); //set the interrupt trigger method of UART2  
DrvUART2_EnableInt(1,1);
```

8.4.35 DrvUART2_IntType

● Prototype

unsigned int DrvUART2_IntType(unsigned int uTXIT, unsigned int uRXIT)

● Description

Set the interrupt trigger method of UART2 RX and TX .

Configure the register 0X40E10[1]/ 0X40E10[3]

● Parameters

uTXIT [in] the interrupt trigger method of TX

0 : Send out the interrupt when the Tx Data Buffer is idle, and the interrupt disappears after the data are written in.

1 : Sent out the interrupt after one piece of data is transmitted by the Tx

uRXIT[in] the interrupt trigger method of RX

0 : Send out the interrupt when the Rx Data Buffer has data, and the interrupt disappears after the data are read.

1 : Send out the interrupt after one piece of data is received by the Rx.

● Include

Peripheral_lib/DrvUART.h

● Return Value

0: Operation successful
Other : Incorrect argument

● Example

```
/* Send out the interrupt when the Tx Data Buffer is idle and the Rx Data Buffer has data */  
DrvUART2_IntType(0, 0) ;
```

8.4.36 DrvUART2_GetTxFlag

● Prototype

unsigned int DrvUART2_GetTxFlag ();

● Description

Get the Tx interrupt flag of UART2.

Configure the register 0x40018[3]

- **Parameters**

None

- **Include**

Peripheral_lib/DrvUART.h

- **Return Value**

1: Interrupted

0: Normal

- **Example**

```
/* Get the Tx interrupt flag. */  
DrvUART2_GetTxFlag();
```

8.4.37 DrvUART2_GetRxFlag

- **Prototype**

```
unsigned int DrvUART2_GetRxFlag ();
```

- **Description**

Get the Rx interrupt flag of UART2.

Configure the register 0x40018[2]

- **Parameters**

None

- **Include**

Peripheral_lib/DrvUART.h

- **Return Value**

0: Operation successful

Other : Incorrect argument

- **Example**

```
/* Get the Rx interrupt flag. */  
unsigned char flag ; flag=DrvUART2_GetRxFlag ();
```

8.4.38 DrvUART2_ClrTxFlag

- **Prototype**

```
void DrvUART2_ClrTxFlag ();
```

- **Description**

Clear the Tx interrupt flag of UART2.

Configure the register 0x40018[3]

- **Parameters**

None

- **Include**

Peripheral_lib/DrvUART.h

- **Return Value**

None

- **Example**

```
/* Clear the Tx interrupt flag. */  
DrvUART2_ClrTxFlag ();
```

8.4.39 DrvUART2_ClrRxFlag

- **Prototype**

```
void DrvUART2_ClrRxFlag ();
```

- **Description**

Clear the Rx interrupt flag of UART2.
Configure the register 0x40018[2]

- **Parameters**

None

- **Include**

Peripheral_lib/DrvUART.h

- **Return Value**

None

- **Example**

```
/* Clear the Rx interrupt flag. */  
DrvUART2_ClrRxFlag ();
```

8.4.40 DrvUART2_Read

- **Prototype**

```
unsigned int DrvUART2_Read();
```

- **Description**

Read data received from UART2.
Read the register 0X40E1C[8:0]

- **Parameters**

None

- **Include**

Peripheral_lib/DrvUART.h

- **Return Value**

The return value is RCREG register data.

- **Example**

```
/* Read the RCREG register data. */
```

```
unsigned int rx_data; rx_data=DrvUART2_Read ();
```

8.4.41 DrvUART2_Write

- **Prototype**

```
void DrvUART2_Write(unsigned int uData);
```

- **Description**

Write data to TXREG register of UART2.

Configure the register 0x40E1C[24:16]

- **Parameters**

uData [in]

data to be sent

- **Include**

Peripheral_lib/DrvUART.h

- **Return Value**

None

- **Example**

```
/* using UART2 to send one byte 0x55 */  
DrvUART2_Write (0x55);
```

8.4.42 DrvUART2_ENABLE_WAKEUP

- **Prototype**

```
void DrvUART2_EnableWakeUp();
```

- **Description**

Enable wake-up mode of UART2

Configure the register 0x40E14[2]=1

- **Parameters**

None

- **Include**

Peripheral_lib/DrvUART2.h

- **Return Value**

None

- **Example**

```
/* Enable wake up. */  
DrvUART2_EnableWakeUp ();
```

8.4.43 DrvUART2_DISABLE_WAKEUP

- **Prototype**

```
void DrvUART2_DisableWakeUp();
```

- **Description**

Disable wake-up mode of UART2
Configure the register 0x40E14[2]=0

- **Parameters**

None

- **Include**

Peripheral_lib/DrvUART.h

- **Return Value**

None

- **Example**

```
/* Disable wake up. */  
DrvUART2_DisableWakeUp ();
```

8.4.44 DrvUART2_ENABLE_AUTO_BAUDRATE

- **Prototype**

```
void DrvUART2_Enable_AutoBaudrate ();
```

- **Description**

Enable Auto Baudrate of UART2
Configure the register 0x40E14[3]=1

- **Parameters**

None

- **Include**

Peripheral_lib/DrvUART.h

- **Return Value**

None

- **Example**

```
/* Enable Auto Baudrate */  
DrvUART2_Enable_AutoBaudrate ();
```

8.4.45 DrvUART2_DISABLE_AUTO_BAUDRATE

- **Prototype**

```
void DrvUART2_Disable_AutoBaudrate ();
```

- **Description**

Disable Auto Baudrate of UART2
Configure the register 0x40E14[3]=0

- **Parameters**

None

- **Include**

Peripheral_lib/DrvUART.h

- **Return Value**

None

- **Example**

```
/* Enable Auto Baudrate */  
DrvUART2_Disable_AutoBaudrate ();
```

8.4.46 DrvUART2_GET_PERR

- **Prototype**

```
unsigned int DrvUART2_GetPERR();
```

- **Description**

Get the Parity Error flag of UART2.
Configure the register 0x40E10[20]

- **Parameters**

None

- **Include**

Peripheral_lib/DrvUART.h

- **Return Value**

1 : Parity error
0 : No parity error

- **Example**

```
/* Get the PERR flag. */  
unsigned char flag; flag=DrvUART2_GetPERR ();
```

8.4.47 DrvUART2_GET_FERR

- **Prototype**

```
unsigned int DrvUART2_GetFERR();
```

- **Description**

Get the FERR flag of UART2.
Configure the register 0x40E10[21]

- **Parameters**

None

- **Include**

Peripheral_lib/DrvUART.h

- **Return Value**

1 : Framing error
0 : No framing error

- **Example**

```
/* Get the FERR flag. */  
unsigned char flag ; flag=DrvUART2_GetFERR ();
```

8.4.48 DrvUART2_GET_OERR

- **Prototype**

```
unsigned int DrvUART2_GetOERR();
```

- **Description**

Get the OERR flag of UART2.
Configure the register 0x40E10[23]

- **Parameters**

None

- **Include**

Peripheral_lib/DrvUART.h

- **Return Value**

1 : Overrun error
0 : No overrun error

- **Example**

```
/* Get the OERR flag. */  
unsigned char flag ; flag=DrvUART2_GetOERR();
```

8.4.49 DrvUART2_GET_NERR

- **Prototype**

```
unsigned int DrvUART2_GetNERR();
```

- **Description**

Get the RX Noise detected flag of UART2.
Read the register 0x40E10[22]

- **Parameters**

None

- **Include**

Peripheral_lib/DrvUART.h

- **Return Value**

1 : Noise detected

0 : Normal

- **Example**

```
/* Get the NERR flag. */  
unsigned char flag; flag=DrvUART2_GetNERR ();
```

8.4.50 DrvUART2_ClrPERR

- **Prototype**

```
unsigned int DrvUART2_ClrPERR();
```

- **Description**

Clear the Parity Error flag of UART2.
Configure the register 0x40E10[20]=0

- **Parameters**

None

- **Include**

Peripheral_lib/DrvUART.h

- **Return Value**

None

- **Example**

```
/* clear the PERR flag. */  
DrvUART2_ClrPERR ();
```

8.4.51 DrvUART2_ClrFERR

- **Prototype**

```
unsigned int DrvUART2_ClrFERR();
```

- **Description**

Clear the RX Fram check error flag of UART2.
Configure the register 0x40E10[21]=0

- **Parameters**

None

- **Include**

Peripheral_lib/DrvUART.h

- **Return Value**

None

- **Example**

```
/* clear the FERR flag. */  
DrvUART2_ClrFERR ();
```

8.4.52 DrvUART2_ClrOERR

- **Prototype**

unsigned int DrvUART2_ClrOERR();

- **Description**

Clear the RX Buffer over run error flag of UART2.

Configure the register 0x40E10[23]=0

- **Parameters**

None

- **Include**

Peripheral_lib/DrvUART.h

- **Return Value**

None

- **Example**

```
/* clear the OERR flag. */
```

```
DrvUART2_ClrOERR ();
```

8.4.53 DrvUART2_ClrNERR

- **Prototype**

unsigned int DrvUART2_ClrNERR();

- **Description**

Clear the RX Noise detected flag of UART2.

Configure the register 0x40E10[22]=0

- **Parameters**

None

- **Include**

Peripheral_lib/DrvUART.h

- **Return Value**

None

- **Example**

```
/* clear the NERR flag. */
```

```
DrvUART2_ClrNERR ();
```

8.4.54 DrvUART2_GETABDOVF

- **Prototype**

unsigned int DrvUART2_GetABDOVF();

- **Description**

Get the RXABDF flag of UART2.

Configure the register 0x40E14[4]

- **Parameters**

None

- **Include**

Peripheral_lib/DrvUART.h

- **Return Value**

1 : A BRG rollover has occurred during Auto-Baud Rate Detect mode

0 : No BRG rollover has occurred

- **Example**

```
/* Get the RXABDF flag. */  
unsigned char flag ; flag=DrvUART2_GetABDOVF();
```

8.4.55 DrvUART2_ClrABDOVF

- **Prototype**

unsigned int DrvUART2_ClrABDOVF(void)

- **Description**

Clear the RXABDF flag.

Configure the register 0X40E14[4]

- **Parameters**

None

- **Include**

Peripheral_lib/DrvUART.h

- **Return Value**

None

- **Example**

```
/* Clear the RXABDF flag */  
DrvUART2_ClrABDOVF();
```

8.4.56 DrvUART2_TRStatus

- **Prototype**

unsigned int DrvUART2_TRStatus(unsigned int uMode)

- **Description**

Read the RX and TX status of UART2.

Read the register 0x40E10[19:16]

- **Parameters**

uMode[in]

0 RXBF; 1 RXBUSY; 2 TXBF; 3 TXBUSY

- **Include**

Peripheral_lib/DrvUART.h

- **Return Value**

0: idle; 1: Busy (for TXBUSY and RXBUSY)

0: empty; 1: full (for TXBF and RXBF)

- **Example**

```
/* Get the TXBF flag. */  
DrvUART2_Write(data);  
While(DrvUART2_TRStatus (2)) ;//wait until TXBF=0
```

8.4.57 DrvUART2_CheckTRMT

- **Prototype**

unsigned int DrvUART2_CheckTRMT(void)

- **Description**

Read the UART2 flag of Transmit Shift Register Status(TXBF).

Read the register 0x40E10[18]

- **Parameters**

None

- **Include**

Peripheral_lib/DrvUART.h

- **Return Value**

0: Transmit Shift Register empty

1: Transmit Shift Register full

- **Example**

```
/* Read the flag of Transmit Shift Register Status */  
DrvUART2_Write(data);  
While(DrvUART2_CheckTRMT ()) ;//wait until TXBF=0
```

8.4.58 DrvUART2_ClkEnable

- **Prototype**

unsigned int DrvUART2_ClkEnable(unsigned int uclk,unsigned int uprescale)

- **Description**

Enable and select the UART2 clock source . Specify the clock source divider
Configure the register 0X40310[21:20]/ 0X40310[18 :16]

- **Parameters**

uclk[in] EUART2 clock source
0 : External high speed oscillator
1 : Internal high speed oscillator
Uprescale[in] : the clock source divider
0000 EUART2 CLOCK SOURCE/1
0001 EUART2 CLOCK SOURCE/2
0010 EUART2 CLOCK SOURCE/4
0011 EUART2 CLOCK SOURCE/8
0100 EUART2 CLOCK SOURCE/16
0101 EUART2 CLOCK SOURCE/32
0110 EUART2 CLOCK SOURCE/64
0111 EUART2 CLOCK SOURCE/128

- **Include**

Peripheral_lib/DrvUART.h

- **Return Value**

0: Operation successful
Other : Incorrect argument

- **Example**

```
/* select the external clock source, divider:clk/1 */  
DrvUART2_ClkEnable (0,0);
```

8.4.59 DrvUART2_ClkDisable

- **Prototype**

```
void DrvUART2_ClkDisable(void) ;
```

- **Description**

Disable the UART2 clock source.
Configure the register 0X40310 [20]=0

- **Parameters**

None

- **Include**

Peripheral_lib/DrvUART.h

- **Return Value**

None

- **Example**

```
/* Disable the UART2 clock source */  
DrvUART2_ClkDisable();
```

8.4.60 DrvUART2_ConfigIO

- **Prototype**

```
unsigned char DrvUART2_ConfigIO(unsigned char ioen,unsigned int uOutputPin) ;
```

- **Description**

Enable and select the IO port as UART2 communication port
Configure the register 0X4084C[3:0]

- **Parameters**

ioen[in] : EURAT1 input/output to port enable control
0: disable
1: enable
uoutputPin[in] : select the UART2 communication port
0 : Port 1.2 =TX2, Port 1.3 =RX2
1 : Port 1.6 =TX2, Port 1.7 =RX2
2 : Port 2.2 =TX2, Port 2.3 =RX2
3 : Port 2.6 =TX2, Port 2.7 =RX2
4 : Port 8.2 =TX2, Port 8.3 =RX2
5 : Port 8.6 =TX2, Port 8.7 =RX2
6 : Port 9.2 =TX2, Port 9.3 =RX2
7 : Port 9.6 =TX2, Port 9.7 =RX2

- **Include**

Peripheral_lib/DrvUART.h

- **Return Value**

0: Operation successful
Other : Incorrect argument

- **Example**

```
/* enable and select PT2.2/PT2.3 as UART2 port*/  
DrvUART2_ConfigIO(1,2);
```

9. CMP Driver

9.1 Introduction

The following functions are included in CMP Manager Section.

Item	Functions	Description
01	DrvCMP_OPEN	Open Comparator
02	DrvCMP_CLOSE	Close Comparator
03	DrvCMP_ENABLE	Enable CMP
04	DrvCMP_POSITIVE_INPUT	Positive reference input
05	DrvCMP_NEGATIVE_INPUT	Negative reference input
06	DrvCMP_INPUT_SWITCH	Comparator input short switch
07	DrvCMP_OUTPUT_FILTER	Digital filter options.
08	DrvCMP_OUTPUT_PIN_ENABLE	Enable the CMP digital output
09	DrvCMP_OUTPUT_PIN_DISABLE	Disable the CMP digital output
10	DrvCMP_OUTPUT_INVERSE	The digital output CMP inverse
11	DrvCMP_ENABLE_INT	CMP Interrupt Enable
12	DrvCMP_DISABLE_INT	CMP Interrupt Disable
13	DrvCMP_READ_INT_FLAG	Read CMP Interrupt flag
14	DrvCMP_CLEAR_INT_FLAG	Clear CMP Interrupt flag
15	DrvCMP_INPUT	Comparator reference input
16	DrvCMP_RLO_CTRL	Internal network configuration
17	DrvCMP_RLO_REFERENCE_VOLTAGE	Comparator reference voltage
18	DrvCMP_ENABLE_NON_OVERLAP	Enable the non-overlap
19	DrvCMP_DISABLE_NON_OVERLAP	Disable the non-overlap
20	DrvCMP_READ_Data	Read CMP Digital output status

9.2 The block diagram of CMP

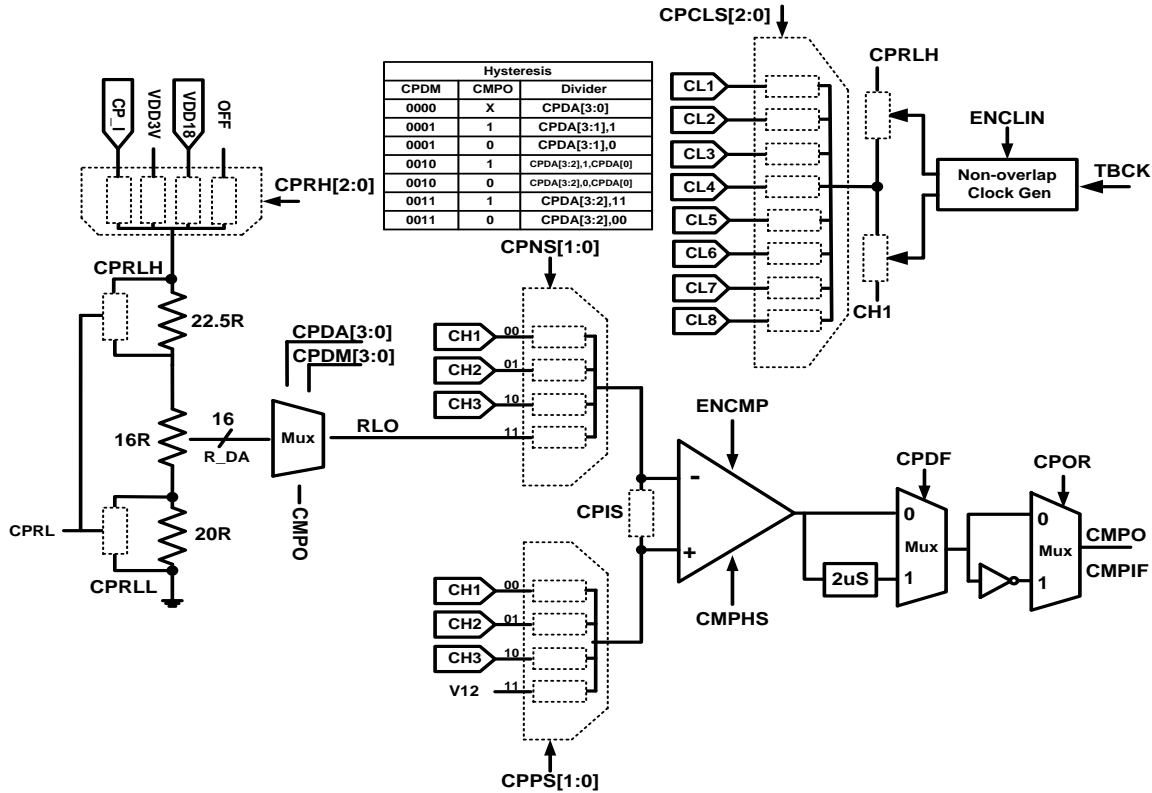

9.3 Type Definition

E_NON_OVERLAP_PIN

Enumeration identifier	Value	Description
E_CL1	0x0	Comparator positive reference input from the PT1.3
E_CL2	0x1	Comparator positive reference input from the PT1.4
E_CL3	0x2	Comparator positive reference input from the PT1.5
E_CL4	0x3	Comparator positive reference input from the PT1.6
E_CL5	0x4	Comparator positive reference input from the PT2.0
E_CL6	0x5	Comparator positive reference input from the PT2.1
E_CL7	0x6	Comparator positive reference input from the PT2.2
E_CL8	0x7	Comparator positive reference input from the PT2.3

E_CMP_PIN

Enumeration identifier	Value	Description
E_CH1	0x0	CMP input source
E_CH2	0x1	CMP input source
E_CH3	0x2	CMP input source
E_V12	0x3	CMP input source
E_RLO	0x3	CMP input source

E_NON_OVERLAP_VREF

Enumeration identifier	Value	Description
E_CMP_DISABLE	0x0	NON OVERLAP reference voltage source
E_CMP_CPI	0x1	NON OVERLAP reference voltage source
E_CMP_VDD3V	0x2	NON OVERLAP reference voltage source
E_CMP_VDD18	0x3	NON OVERLAP reference voltage source

9.4 Functions

9.4.1 DrvCMP_OPEN

- **Prototype**

unsigned int DrvCMP_Open (uPowerMode , uCPDF, uCPOR)

- **Description**

Enable Comparator, Power modes can choose low power or normal , whether the comparator output after deglitch filter, set output signal whether the reverse or not
Configure the register 0X41800[3:1]

- **Parameter**

uPowerMode [in] Comparator low power mode enable.

0 : Low power mode

1 : Normal mode

uCPDF [in] Comparator output deglitch filter

1: With 2us delay deglitch filter

0 : No deglitch filter

uCPOR [in] Output inverse control

0 : Normal

1 : Inverse

- **Include**

Peripheral_lib/DrvCMP.h

- **Return Value**

0: Operation successful

Other : Incorrect argument

- **Example**

```
/* Enable comparator, Choose low power mode and 2us deglitch filter. */
```

```
DrvCMP_Open (0,1,0);
```

9.4.2 DrvCMP_CLOSE

- **Prototype**

void DrvCMP_Close (void)

- **Description**

Close comparator

Configure the register 0X41800[0]

- **Parameter**

None

- **Include**

Peripheral_lib/DrvCMP.h

- **Return Value**

None

- **Example**

```
/* Close comparator */
```

```
DrvCMP_Close();
```

9.4.3 DrvCMP_ENABLE

- **Prototype**

void DrvCMP_Enable (void)

- **Description**

Enable CMP

Configure the register 0X41800[0]

- **Parameter**

None

- **Include**

Peripheral_lib/DrvCMP.h

- **Return Value**

None

- **Example**

```
/* Enable CMP */
```

```
DrvCMP_Enable();
```

9.4.4 DrvCMP_POSITIVE_INPUT

- **Prototype**

unsigned int DrvCMP_PInput (uCPPS)

- **Description**

Comparator positive reference input selection.

Configure the register 0X41804[5:4]

- **Parameter**

uCPPS [in] Comparator positive reference input selection.

0 : CH1

1 : CH2

2 : CH3

3 : V12 (V12=1.2V)

- **Include**

Peripheral_lib/DrvCMP.h

- **Return Value**

0: Operation successful

Other : Incorrect argument

- **Example**

```
/* Select the CMP positive input of CH1. */
```

```
DrvCMP_PInput (0);
```

9.4.5 DrvCMP_NEGATIVE_INPUT

- **Prototype**

unsigned int DrvCMP_NInput (uCPNS)

- **Description**

Comparator negative reference input selection.

Configure the register 0X41804[1:0]

- **Parameter**

uOPNS [in] Comparator negative reference input selection.

0 : CH1

1 : CH2

2 : CH3

3 : RLO

- **Include**

Peripheral_lib/DrvCMP.h

- **Return Value**

0: Operation successful
Other : Incorrect argument

- **Example**

```
/* Select the CMP negative input of CH1. */  
DrvCMP_NInput (0);
```

9.4.6 DrvCMP_INPUT_SWITCH

- **Prototype**

unsigned int DrvCMP_InputSwitch (uInputSwitch)

- **Description**

Comparator input short switch.
Configure the register 0X41800[4]

- **Parameter**

uInputSwitch[in] Comparator input short switch.
0 : Open
1 : Short

- **Include**

Peripheral_lib/DrvCMP.h

- **Return Value**

0: Operation successful
Other : Incorrect argument

- **Example**

```
/* Comparator input short */  
DrvCMP_InputSwitch (1);
```

9.4.7 DrvCMP_OUTPUT_FILTER

- **Prototype**

unsigned int DrvCMP_OuputFilter(uFilter)

- **Description**

The output of CMP connected with the digital filter options.
Configure the register 0X41800[2]

- **Parameter**

uFilter[in]
0 : Disable
1 : Enable(pass a 2us deglitch)

- **Include**

Peripheral_lib/DrvCMP.h

- **Return Value**

0: Operation successful

Other : Incorrect argument

- **Example**

```
/* CMP output delay 2us. */
```

```
DrvCMP_ OuputFilter (1);
```

9.4.8 DrvCMP_OUTPUT_PIN_ENABLE

- **Prototype**

unsigned int DrvCMP_OutputPinEnable (E_OUTPUT_PIN uPin)

- **Description**

Enable the CMP digital output to port.

Configure the register 0X40840[16]

- **Parameter**

uPin [in]

0 : PT1.7

- **Include**

Peripheral_lib/DrvCMP.h

- **Return Value**

0: Operation successful

Other : Incorrect argument

- **Example**

```
/* Enable the CMP digital output */
```

```
DrvCMP_OutputPinEnable ();
```

9.4.9 DrvCMP_OUTPUT_PIN_DISABLE

- **Prototype**

void DrvCMP_OutputPinDisable (void)

- **Description**

Disable the CMP digital output to port.

Configure the register 0X40840[16]

- **Parameter**

None

- **Include**

Peripheral_lib/DrvCMP.h

- **Return Value**

None

- **Example**

```
/* Disable the CMP digital output */  
DrvCMP_OutputPinDisable ();
```

9.4.10 DrvCMP_OUTPUT_PIN_INVERSE

- **Prototype**

```
unsigned int DrvCMP_OutputInverse(unsigned int ulnv)
```

- **Description**

The digital output CMP inverse control.
Configure the register 0X41800[3]

- **Parameter**

ulnv [in]

0 : Normal

1 : Output Reverse

- **Include**

Peripheral_lib/DrvCMP.h

- **Return Value**

0: Operation successful

Other : Incorrect argument

- **Example**

```
/* Set CMP digital output inverse control */  
DrvCMP_OutputInverse (1);
```

9.4.11 DrvCMP_ENABLE_INT

- **Prototype**

```
void DrvCMP_EnableInt (void)
```

- **Description**

CMP Interrupt Enable

Configure the register 0X4000C[17]

- **Parameter**

None

- **Include**

Peripheral_lib/DrvCMP.h

- **Return Value**

None

- **Example**

```
/* Enable CMP interrupt */  
DrvCMP_EnableInt ();
```

9.4.12 DrvCMP_DISABLE_INT

- **Prototype**

```
void DrvCMP_DisableInt (void)
```

- **Description**

CMP Interrupt Disable
Configure the register 0X4000C[17]

- **Parameter**

None

- **Include**

Peripheral_lib/DrvCMP.h

- **Return Value**

None

- **Example**

```
/* Disable CMP interrupt */  
DrvCMP_DisableInt ();
```

9.4.13 DrvCMP_READ_INT_FLAG

- **Prototype**

unsigned int DrvCMP_ReadIntFlag (void)

- **Description**

Read CMP interrupt flag.

Configure the register 0X4000C[1]

- **Parameter**

None

- **Include**

Peripheral_lib/DrvCMP.h

- **Return Value**

0 : Normal. Interrupt flag is 0

1 : Interrupted. Interrupt flag is 1

>1: Invalid return value

- **Example**

```
/* Read CMP interrupt flag */
```

```
DrvCMP_ReadIntFlag ();
```

9.4.14 DrvCMP_CLEAR_INT_FLAG

- **Prototype**

void DrvCMP_ClearIntFlag (void)

- **Description**

Clear CMP interrupt flag.

Configure the register 0X4000C[1]

- **Parameter**

None

- **Include**

Peripheral_lib/DrvCMP.h

- **Return Value**

None

- **Example**

```
/* Clear CMP interrupt flag */
```

```
DrvCMP_ClearIntFlag ();
```

9.4.15 DrvCMP_INPUT

- **Prototype**

unsigned int DrvCMP_Input (uPositiveInput, uNegativeInput,uInputSwitch)

- **Description**

Comparator positive and negative reference input selection. Set the Input short switch.

Configure the register 0X41804[1:0] / 0X41804[5 :4],0X41800[4] .

- **Parameter**

uPositiveInput [in] Comparator positive reference input selection.

0 : CH1

1 : CH2

2 : CH3

3 : V12

uNegativeInput [in] Comparator negative reference input selection.

0 : CH1

1 : CH2

2 : CH3

3 : RLO

uInputSwitch[in] Comparator input short switch.

0 : Open

1 : Short

- **Include**

Peripheral_lib/DrvCMP.h

- **Return Value**

0: Operation successful

Other : Incorrect argument

- **Example**

```
/* Select CPPS=CH1,CPNS=CH3, the input switch is open */
```

```
DrvCMP_Input (0,2,0);
```

9.4.16 DrvCMP_RLO_CTRL

- **Prototype**

unsigned int DrvCMP_RLO_Ctrl (uCPDA ,uCPDM)

- **Description**

Comparator network internal network configuration

Configure the register 0X41804[23:20] / 0X41804[19:16]

● Parameter

uCPDA[in] Comparator internal resistor ladder control.

0 : 0

1 : 1/16 (CPRLH – CPRLL)

2 : 2/16 (CPRLH – CPRLL)

3 : 3/16 (CPRLH – CPRLL)

4 : 4/16 (CPRLH – CPRLL)

5 : 5/16 (CPRLH – CPRLL)

6 : 6/16 (CPRLH – CPRLL)

7 : 7/16 (CPRLH – CPRLL)

8 : 8/16 (CPRLH – CPRLL)

9 : 9/16 (CPRLH – CPRLL)

10 : 10/16 (CPRLH – CPRLL)

11 : 11/16 (CPRLH – CPRLL)

12 : 12/16 (CPRLH – CPRLL)

13 : 13/16 (CPRLH – CPRLL)

14 : 14/16 (CPRLH – CPRLL)

15 : 15/16 (CPRLH – CPRLL)

uCPDM [3:0] Determine if CPDA[3]~[0] is used for hysteresis and control by CMPO

uCPDM [3] 0 : disable

 1 : enable

uCPDM [2] 0 : disable

 1 : enable

uCPDM [1] 0 : disable

 1 : enable

uCPDM [0] 0 : disable

 1 : enable

● Include

Peripheral_lib/DrvCMP.h

● Return Value

0: Operation successful

Other : Incorrect argument

● Example

```
/* Set CPDM=0101,CPDA=0011 */
```

```
DrvCMP_RLO_Ctrl(0x03,0x05);
```

9.4.17 DrvCMP_RLO_REFERENCE_VOLTAGE

- **Prototype**

unsigned int DrvCMP_RLO_refV (uCPRH, uCPRLS)

- **Description**

Comparator reference voltage control

Configure the register 0X41808[2:0] / 0X41808[4]

- **Parameter**

uCPRH [in] Comparator resistor ladder high voltage selection.

0 : off(high impendent)

1 : CP_I charge pump input

2 : VDD3V (system power voltage)

3 : VDD18 (digital power voltage)

uCPRLS [in] Comparator resistor ladder short switch.

0 : Off

1 : On

- **Include**

Peripheral_lib/DrvCMP.h

- **Return Value**

E_SUCCESS: Operation successful

E_DRVCMP_ARGUMENT: Incorrect argument

- **Example**

/* Set comparator resistor ladder high voltage from VDD,18 resistor ladder short */

DrvCMP_RLO_refV (3,1);

9.4.18 DrvCMP_ENABLE_NON_OVERLAP

- **Prototype**

unsigned int DrvCMP_EnableNonOverlap (E_NON_OVERLAP_PIN uInput)

- **Description**

Enable the non-overlap and select reference input.

Configure the register 0X41808[19:16]

- **Parameter**

uInput [in] Comparator positive reference input selection.

0 : CL1 1 : CL2 2 : CL3 3 : CL4

4 : CL5 5 : CL6 6 : CL7 7 : CL8

- **Include**

Peripheral_lib/DrvCMP.h

- **Return Value**

0: Operation successful

Other : Incorrect argument

- **Example**

```
/* Enable the non-overlap and select CL1 reference input. */  
DrvCMP_EnableNonOverlap (0)
```

9.4.19 DrvCMP_DISABLE_NON_OVERLAP

- **Prototype**

```
void DrvCMP_DisableNonOverlap ( void)
```

- **Description**

Disable the non-overlap
Configure the register 0X41808[16]

- **Parameter**

None

- **Include**

Peripheral_lib/DrvCMP.h

- **Return Value**

None

- **Example**

```
/* Disable the non-overlap. */  
DrvCMP_DisableNonOverlap ();
```

9.4.20 DrvCMP_READ_Data

- **Prototype**

```
unsigned int DrvCMP_ReadData (void)
```

- **Description**

Read CMP Digital output status.
Configure the register 0X41800[16]

- **Parameter**

None

- **Include**

Peripheral_lib/DrvCMP.h

- **Return Value**

0: Negative input > positive input
1: Positive input > negative

- **Example**

```
/* Read CMP Digital output status */  
unsigned char flag; flag=DrvCMP_ReadData ();
```

10. OPAMP Driver

10.1 Introduction

The following functions are included in OPA Manager Section.

Item	Functions	Description
01	DrvOP_OPEN	Enable OPAMP
02	DrvOP_CLOSE	Close OPAMP
03	DrvOP_POSITIVE_INPUT	Positive input selection
04	DrvOP_NEGATIVE_INPUT	Negative input selection.
05	DrvOP_OPO_OUTPUT_ENABLE	OPAMP output enable
06	DrvOP_OPO_OUTPUT_DISABLE	OPAMP output disable
07	DrvOP_OUTPUT_FILTER	OPAMP digital filter options
08	DrvOP_OUTPUT_PIN_ENABLE	Enable digital output to port.
09	DrvOP_OUTPUT_PIN_DISABLE	Disable digital output to port.
10	DrvOP_OUTPUT_INVERSE.	The digital output inverse
11	DrvOP_OUTPUT_WITH_CPCLK.	CPCLK multiplier selection.
12	DrvOP_ENABLE_INT	OPA Interrupt Enable
13	DrvOP_DISABLE_INT	OPA Interrupt Disable
14	DrvOP_READ_INT_FLAG	Read OPAMP interrupt flag
15	DrvOP_CLEAR_INT_FLAG	Clear OPAMP interrupt flag.
16	DrvOP_FEEDBACK	OPAMP feedback settings

10.2 The block diagram of OPAMP

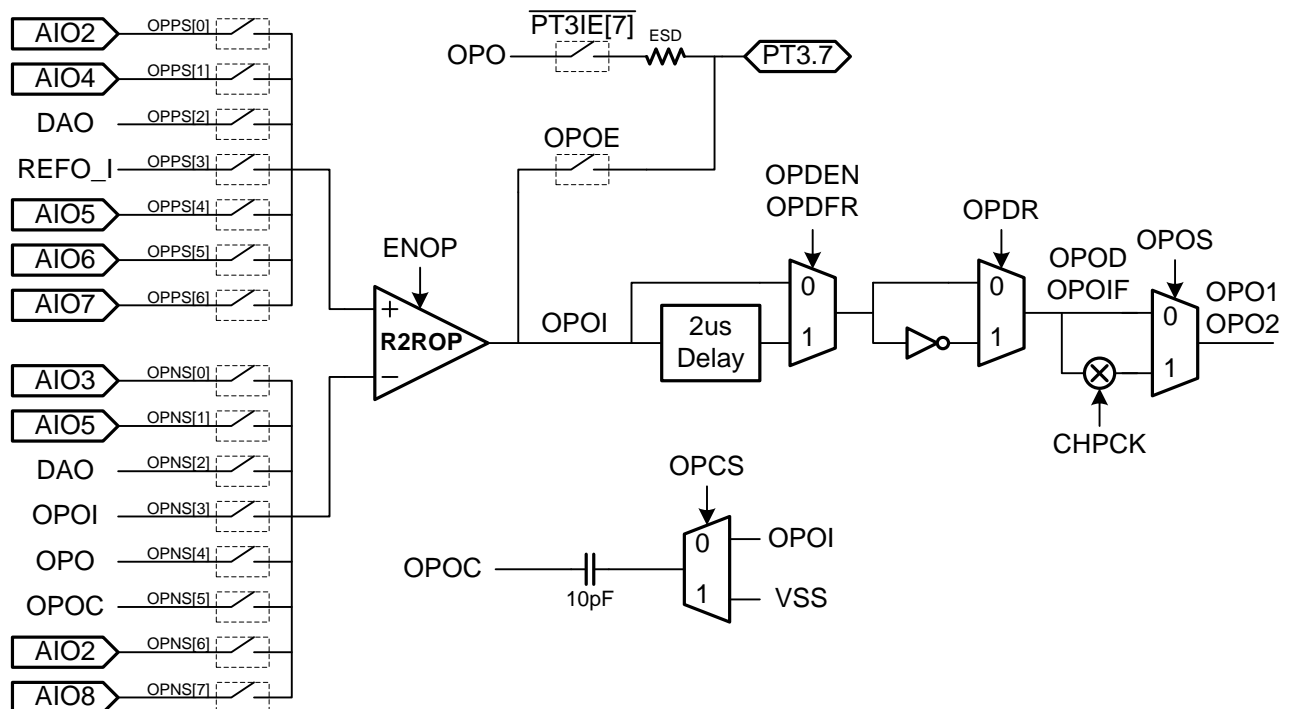

10.3 Type Definition

E_OUTPUT_PIN

Enumeration identifier	Value	Description
E_OPO1	0x0	OPAMP output digital output from the PT3.0
E_OPO2	0x1	OPAMP output digital output from the PT3.1

E_OPN_PPIN

Enumeration identifier	Value	Description
E_OPP_AIO2	0x1	OPAMP input from AIO2
E_OPP_AIO4	0x2	OPAMP input from AIO4
E_OPP_DAO	0x4	OPAMP input from DAO
E_OPP_REFO_I	0x8	OPAMP input from REFO_I
E_OPP_AIO5	0x10	OPAMP input from AIO5
E_OPP_AIO6	0x20	OPAMP input from AIO6
E_OPP_AIO7	0x40	OPAMP input from AIO7
E_OPN_AIO3	0x1	OPAMP input from AIO3
E_OPN_AIO5	0x2	OPAMP input from AIO5
E_OPN_DAO	0x4	OPAMP input from DAO
E_OPN_OPOI	0x8	OPAMP input from OPOI
E_OPN_OPO	0x10	OPAMP input from OPO
E_OPN_OPC	0x20	OPAMP input from OPC
E_OPN_AIO2	0x40	OPAMP input from AIO2
E_OPN_AIO8	0x80	OPAMP input from AIO8

10.4 Functions

10.4.1 DrvOP_OPEN

- **Prototype**

void DrvOP_Open (void)

- **Description**

Enable OPAMP

Configure the register 0X41900[0]

- **Parameter**

None

- **Include**

Peripheral_lib/DrvOP.h

- **Return Value**

None

- **Example**

```
/* Enable OP */  
DrvOP_Open ();
```

10.4.2 DrvOP_CLOSE

- **Prototype**

void DrvOP_Close (void)

- **Description**

Close OPAMP

Configure the register 0X41900[0]

- **Parameter**

None

- **Include**

Peripheral_lib/DrvOP.h

- **Return Value**

None

- **Example**

```
/* Close OP */  
DrvOP_Close();
```

10.4.3 DrvOP_POSITIVE_INPUT

- **Prototype**

unsigned int DrvOP_PInput (uOPPS)

- **Description**

Rail-to-rail OPAMP positive input selection.

Configure the register 0X41904[22:16]

- **Parameter**

uOPPS [in] Rail-to-rail OPAMP positive input selection. It could be 0~0x7f

uOPPS[6] : OPAMP positive input channel 6

0 : Turn-off: High impendent

1 : Turn-on and connect to AIO7

uOPPS[5] : OPAMP positive input channel 5

0 : Turn-off: High impendent

1 : Turn-on and connect to AIO6

uOPPS[4] : OPAMP positive input channel 4

0 : Turn-off: High impendent

1 : Turn-on and connect to AIO5

uOPPS[3] : OPAMP positive input channel 3

0 : Turn-off: High impendent

1 : Turn-on and connect to REFO_I

uOPPS[2] : OPAMP positive input channel 2

0 : Turn-off: High impendent

1 : Turn-on and connect to DAO

uOPPS[1] : OPAMP positive input channel 1

0 : Turn-off: High impendent

1 : Turn-on and connect to AIO4

uOPPS[0] : OPAMP positive input channel 0

0 : Turn-off: High impendent

1 : Turn-on and connect to AIO2

- **Include**

Peripheral_lib/DrvOP.h

- **Return Value**

0: Operation successful

Other : Incorrect argument

- **Example**

```
/* Selection the Rail-to-rail OPAMP positive input of AIO2 and AIO4. */
```

```
DrvOP_PInput(0x1|| 0x2);
```

10.4.4 DrvOP_NEGATIVE_INPUT

- **Prototype**

unsigned int DrvOP_NInput (uOPNS)

- **Description**

Rail-to-rail OPAMP negative input selection.

Configure the register 0X41904[7:0]

- **Parameter**

uOPPS [in] Rail-to-rail OPAMP negative input selection register. It could be 0~0xff

uOPNS[7] : OPAMP negative input channel 7

0 : Turn-off: High impendent

1 : Turn-on and connect to AIO8

uOPNS[6] : OPAMP negative input channel 6

0 : Turn-off: High impendent

1 : Turn-on and connect to AIO2

uOPNS[5] : OPAMP negative input channel 5

0 : Turn-off: High impendent

1 : Turn-on and connect to OPC: Internal 10pF capacitor

uOPNS[4] : OPAMP negative input channel 4

0 : Turn-off: High impendent

1 : Turn-on and connect to OPO: Internal OPAMP output

uOPNS[3] : OPAMP negative input channel 3

0 : Turn-off: High impendent

1 : Turn-on and connect to OPOI: External OPAMP output

uOPNS[2] : OPAMP negative input channel 2

0 : Turn-off: High impendent

1 : Turn-on and connect to DAO

uOPNS[1] : OPAMP negative input channel 1

0 : Turn-off: High impendent

1 : Turn-on and connect to AI5

uOPNS[0] : OPAMP negative input channel 0

0 : Turn-off: High impendent

1 : Turn-on and connect to AI3

- **Include**

Peripheral_lib/DrvOP.h

- **Return Value**

0: Operation successful

Other : Incorrect argument

- **Example**

```
/* Selection the Rail-to-rail OPAMP negative input of AIO3 and AIO5. */  
DrvOP_NInput (0x1||0x2);
```

10.4.5 DrvOP_OPO_OUTPUT_ENABLE

- **Prototype**

```
void DrvOP_OPOoutEnable(void)
```

- **Description**

OPAMP output enable
Configure the register 0X41900[1]

- **Parameter**

None

- **Include**

Peripheral_lib/DrvOP.h

- **Return Value**

None

- **Example**

```
/* OPAMP output enable */  
DrvOP_OPOoutEnable ();
```

10.4.6 DrvOP_OPO_OUTPUT_DISABLE

- **Prototype**

```
void DrvOP_OPOoutDisable(void)
```

- **Description**

OPAMP output disable
Configure the register 0X41900[1]

- **Parameter**

None

- **Include**

Peripheral_lib/DrvOP.h

- **Return Value**

None

- **Example**

```
/* OPAMP output disable */  
DrvOP_OPOoutDisable ();
```

10.4.7 DrvOP_OUTPUT_FILTER

- **Prototype**

unsigned int DrvOP_OuputFilter(uFilter)

- **Description**

The output of OPAMP connected with the digital filter options.

Configure the register 0X41900[3]

- **Parameter**

uFilter[in]

0 : Disable

1 : Enable(pass a 2us deglitch)

- **Include**

Peripheral_lib/DrvOP.h

- **Return Value**

0: Operation successful

Other: Incorrect argument

- **Example**

```
/* OPAMP output delay 2us. */
```

```
DrvOP_OuputFilter (1);
```

10.4.8 DrvOP_OUTPUT_PIN_ENABLE

- **Prototype**

unsigned int DrvOP_OutputPinEnable (E_OUTPUT_PIN uPin)

- **Description**

Enable and select the OPAMP digital output to port.

Configure the register 0x41900[2], 0x40840[19:18]

- **Parameter**

uPin [in]

0 : PT3.0

1 : PT3.1

- **Include**

Peripheral_lib/DrvOP.h

- **Return Value**

0: Operation successful

Other : Incorrect argument

- **Example**

```
/* Enable the OPAMP digital output IO=PT3.0*/
```

DrvOP_OutputPinEnable (0);

10.4.9 DrvOP_OUTPUT_PIN_DISABLE

- **Prototype**

void DrvOP_OutputPinDisable (void)

- **Description**

Disable the OPAMP digital output to port.

Configure the register 0x41900[2]=0, 0x40840[18]=0

- **Parameter**

None

- **Include**

Peripheral_lib/DrvOP.h

- **Return Value**

None

- **Example**

```
/* Disable the OPAMP digital output */
```

```
DrvOP_OutputPinDisable ();
```

10.4.10 DrvOP_OUTPUT_PIN_INVERSE.

- **Prototype**

unsigned int DrvOP_OutputInverse(uInv)

- **Description**

The digital output op amp inverse control.

Configure the register 0X41900[5]

- **Parameter**

uInv [in]

0 : Normal

1 : Output Reverse

- **Include**

Peripheral_lib/DrvOP.h

- **Return Value**

0: Operation successful

Other : Incorrect argument

- **Example**

```
/* Set OPAMP digital output inverse control */
```

DrvOP_OutputInverse ();

10.4.11 DrvOP_OUTPUT_WITH_CHPCK

- **Prototype**

unsigned int DrvOP_OutputWithCHPCK(uCHPCK)

- **Description**

OPO1/OPO2 with/without CHPCK multiplier selection.

Configure the register 0X41900[6]

NOTE: the old function is unsigned int DrvOP_OutputWithCPCLK(uCPCLK) . Its operation is the same as DrvOP_OutputWithCHPCK(uCHPCK)

- **Parameter**

uCHPCK [in]

0 : No CHPCK multiplier, OPO1/OPO2 is equal to OPOD

1 : With CHPCK multiplier, OPO1/OPO2 is OPOD multiply by CHPCK

- **Include**

Peripheral_lib/DrvOP.h

- **Return Value**

0: Operation successful

Other: Incorrect argument

- **Example**

```
/* Set the output with CHPCK */
```

```
DrvADC_ClkEnable(0,0); // must enable ADC clock source first
```

```
DrvOP_OutputWithCHPCK (1); //enable CHPCK multiplier
```

10.4.12 DrvOP_ENABLE_INT

- **Prototype**

void DrvOP_EnableInt (void)

- **Description**

OPAMP Interrupt Enable

Configure the register 0X4000C[16]

- **Parameter**

None

- **Include**

Peripheral_lib/DrvOP.h

- **Return Value**

None

- **Example**

```
/* Enable OPAMP interrupt */  
DrvOP_EnableInt ();
```

10.4.13 DrvOP_DISABLE_INT

- **Prototype**

```
void DrvOP_DisableInt (void)
```

- **Description**

OPAMP Interrupt Disable

Configure the register 0X4000C[16]

- **Parameter**

None

- **Include**

Peripheral_lib/DrvOP.h

- **Return Value**

None

- **Example**

```
/* Disable OPAMP interrupt */  
DrvOP_DisableInt ();
```

10.4.14 DrvOP_READ_INT_FLAG

- **Prototype**

```
unsigned int DrvOP_ReadIntFlag (void)
```

- **Description**

Read OPAMP interrupt flag.

Read the register 0X4000C[0]

- **Parameter**

None

- **Include**

Peripheral_lib/DrvOP.h

- **Return Value**

0 : Interrupt flag is0

1 : Interrupt flag is1

>1: Invalid return value

- **Example**

```
/* Read OPAMP interrupt flag */
```

```
DrvOP_ReadIntFlag ();
```

10.4.15 DrvOP_CLEAR_INT_FLAG

- **Prototype**

```
void DrvOP_ClearIntFlag (void)
```

- **Description**

Clear OPAMP interrupt flag.

Clear the register 0X4000C[0]

- **Parameter**

None

- **Include**

Peripheral_lib/DrvOP.h

- **Return Value**

None

- **Example**

```
/* Clear OPAMP interrupt flag */  
DrvOP_ClearIntFlag ();
```

10.4.16 DrvOP_FEEDBACK

- **Prototype**

```
unsigned int DrvOP_Feedback(uFeedback)
```

- **Description**

OPAMP feedback or sample capacitor connection settings

Configure the register 0X41900[4]

- **Parameter**

uFeedback [in]

0 : The capacitor is used as integrated capacitor. The bottom plate connects to OPOI

1 : The capacitor is used as sample capacitor. The bottom plate connects to VSSA

- **Include**

Peripheral_lib/DrvOP.h

- **Return Value**

0: Operation successful

Other : Incorrect argument

- **Example**

```
/* OPAMP feedback capacitor connected */  
DrvOP_Feedback ();
```

11. PMU Driver

11.1 Introduction

The following functions are included in Power Manager Section.

Item	Functions	Description
01	DrvPMU_VDDA_VOLTAGE	VDDA voltage selection
02	DrvPMU_VDDA_LDO_ENABLE_CONTROL	VDDA LDO enable control
03	DrvPMU_BANDGAP_ENABLE	Band gap enable control
04	DrvPMU_BANDGAP_DISABLE	Band gap disable control
05	DrvPMU_CHARGE_PUMP_ENABLE	Charge Pump enable
06	DrvPMU_CHARGE_PUMP_DISABLE	Charge Pump disable
07	DrvPMU_REFO_ENABLE	Reference buffer enable
08	DrvPMU_REFO_DISABLE	Reference buffer disable
09	DrvPMU_ADC_ANALOG_GROUND	ADC analog ground source
10	DrvPMU_LDO_LOW_POWER	VDD LDO low power

11.2 The block diagram of PowerManage

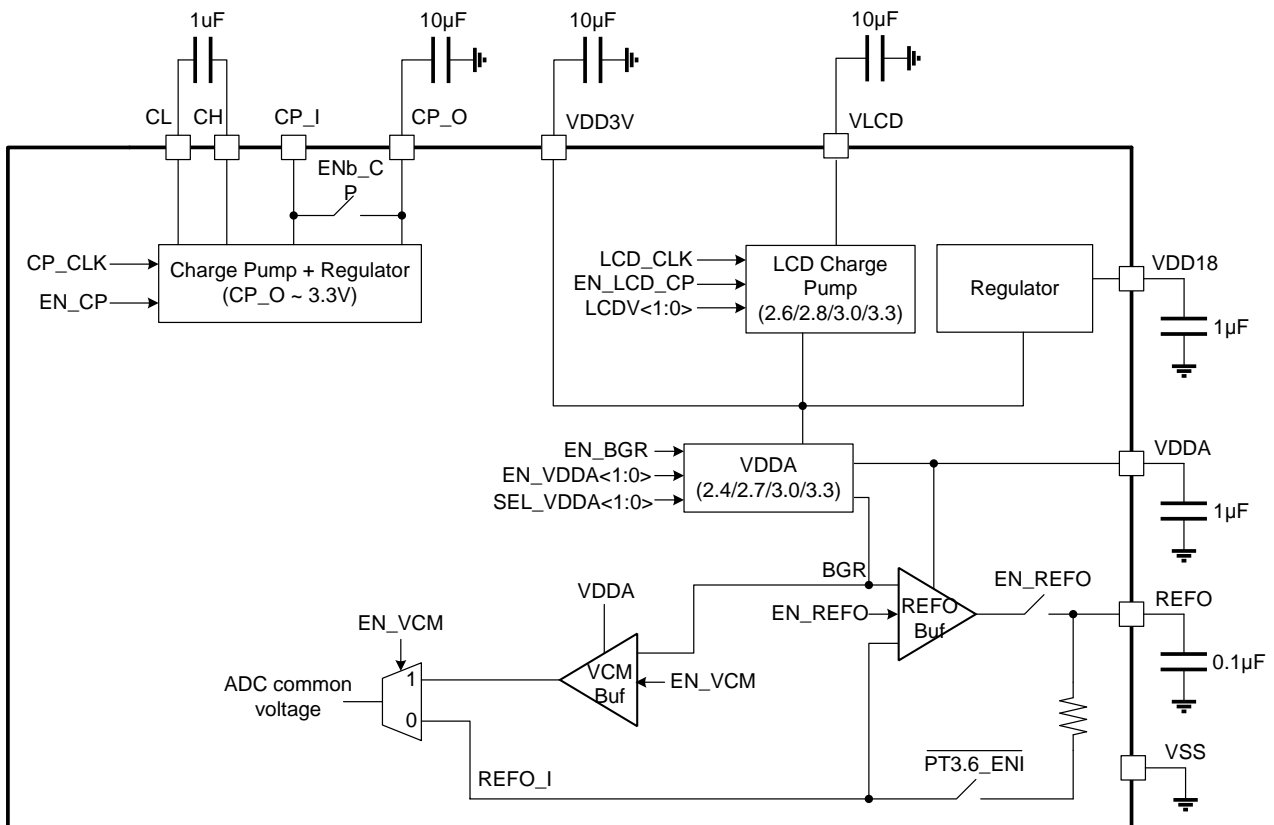

11.3 Type Definition

E_VDDA_OUTPUT_VOLTAGE

Enumeration identifier	Value	Description
E_VDDA2_4	0x0	Select the VDDA voltage of 2.4V
E_VDDA2_7	0x1	Select the VDDA voltage of 2.7V
E_VDDA3_0	0x2	Select the VDDA voltage of 3.0V
E_VDDA3_3	0x3	Select the VDDA voltage of 3.3V

E_VDDA_LDO_ENABLE_CONTROL

Enumeration identifier	Value	Description
E_HighZ	0x0	Select the VDDA voltage of 0V
E_VDD3V	0x1	Select the VDDA voltage of 3V
E_PullDown	0x2	Select the VDDA voltage of 0V
E_LDO	0x3	Select the VDDA voltage of 2.4~3.3V

11.4 Functions

11.4.1 DrvPMU_VDDA_VOLTAGE

- **Prototype**

unsigned int DrvPMU_VDDA_Voltage(E_VDDA_OUTPUT_VOLTAGE uVoltage)

- **Description**

VDDA output voltage selection

Configure the register 0X40400[19:18]

- **Parameter**

uVoltage [in]

0 : 2.4V

1 : 2.7V

2 : 3.0V

3 : 3.3V

- **Include**

Peripheral_lib/DrvPMU.h

- **Return Value**

0: Operation successful

Other : Incorrect argument

- **Example**

```
/* Select the VDDA voltage of 2.7V. */
```

```
DrvPMU_VDDA_Voltage(E_VDDA2_7);
```

11.4.2 DrvPMU_VDDA_LDO_ENABLE_CONTROL

- **Prototype**

unsigned int DrvPMU_VDDA_LDO_Ctrl(E_VDDA_LDO_ENABLE_CONTROL uCtrl)

- **Description**

VDDA LDO enable control.

Configure the register 0X40400 [17:16]

- **Parameter**

uCtrl [in]

0 : High Z VDDA=0

1 : VDD3V VDDA=VDD3V

- 2 : Weak pull down VDDA=0
- 3 : LDO output voltage regulation

- **Include**

Peripheral_lib/DrvPMU.h

- **Return Value**

- 0: Operation successful
- Other : Incorrect argument

- **Example**

```
/* Select the VDDA LDO enable. VDDA=2.7V*/  
DrvPMU_VDDA_LDO_Ctrl(E_LDO);  
DrvPMU_VDDA_Voltage(E_VDDA2_7);
```

11.4.3 DrvPMU_BANDGAP_ENABLE

- **Prototype**

void DrvPMU_BandgapEnable(void)

- **Description**

Bandgap enable control.
Configure the register 0X40400[4]

- **Parameter**

None

- **Include**

Peripheral_lib/DrvPMU.h

- **Return Value**

None

- **Example**

```
/* Enable bandgap. */  
DrvPMU_BandgapEnable ();
```

11.4.4 DrvPMU_BANDGAP_DISABLE

- **Prototype**

void DrvPMU_BandgapDisable(void)

- **Description**

Bandgap disable control.
Configure the register 0X40400[4]

- **Parameter**

None

- **Include**

Peripheral_lib/DrvPMU.h

- **Return Value**

None

- **Example**

```
/* Disable bandgap. */  
DrvPMU_BandgapDisable ();
```

11.4.5 DrvPMU_CHARGE_PUMP_ENABLE

- **Prototype**

```
void DrvPMU_ChargePumpEnable(void)
```

- **Description**

ChargePump enable control.

Note :Enable the ADC clock source before use it. Because he ChargePump boost-up circuit need to use ADC clock as clock source.

Configure the register 0X40400[2]

- **Parameter**

None

- **Include**

Peripheral_lib/DrvPMU.h

- **Return Value**

None

- **Example**

```
/* Enable charge pump */  
DrvADC_ClkEnable(0,0) ; //enable ADC clock source  
DrvPMU_ChargePumpEnable (); // Enable charge pump
```

11.4.6 DrvPMU_CHARGE_PUMP_DISABLE

- **Prototype**

```
void DrvPMU_ChargePumpDisable (void)
```

- **Description**

Charge pump disable control.

Configure the register 0X40400[2]

- **Parameter**

None

- **Include**

Peripheral_lib/DrvPMU.h

- **Return Value**

None

- **Example**

```
/* Disable charge pump. */  
DrvPMU_ChargePumpDisable ();
```

11.4.7 DrvPMU_REFO_ENABLE

- **Prototype**

```
void DrvPMU_REFO_Enable(void)
```

- **Description**

Reference buffer enable control.

The output voltage is 1.2 v. Need to enable the Bandgap.

Configure the register 0X40400[1]

- **Parameter**

None

- **Include**

Peripheral_lib/DrvPMU.h

- **Return Value**

None

- **Example**

```
/* Enable REFO. */  
DrvPMU_BandgapEnable() ; // enable the Bandgap  
DrvPMU_REFO_Enable();
```

11.4.8 DrvPMU_REFO_DISABLE

- **Prototype**

```
void DrvPMU_REFO_Disable(void)
```

- **Description**

Reference buffer disable control.

Configure the register 0X40400[1]

- **Parameter**

None

- **Include**

Peripheral_lib/DrvPMU.h

- **Return Value**

None

- **Example**

```
/* Disable REFO. */
```

```
DrvPMU_REFO_Disable ();
```

11.4.9 DrvPMU_ADC_ANALOG_GROUND

- **Prototype**

```
unsigned int DrvPMU_AnalogGround(uAG)
```

- **Description**

ADC analog ground source selection.

Configure the register 0X40400[3]

- **Parameter**

uAG [in]

0 : External

1 : Enable buffer and use internal source(need to work with ADC)

- **Include**

Peripheral_lib/DrvPMU.h

- **Return Value**

0: Operation successful

Other : Incorrect argument

- **Example**

```
/* Select the analog ground of external. */
```

```
DrvPMU_AnalogGround(0);
```

11.4.10 DrvPMU_LDO_LOW_POWER

- **Prototype**

```
unsigned int DrvPMU_LDO_LowPower(uLP)
```

- **Description**

VDD LDO with low power control.

Configure the register 0X40400 [0]

- **Parameter**

uLP [in]

0 : Normal(form sleep mode make up needs to set 0)

1 : Low power

- **Include**

Peripheral_lib/DrvPMU.h

- **Return Value**

0: Operation successful

Other : Incorrect argument

- **Example**

```
/* Enable the LDO of low power. */
```

```
DrvPMU_LDO_LowPower(1);
```

12. 8-bit Resistance Ladder Driver

12.1 Introduction

The following functions are included in 8-bit resistance ladder (the file:DrvDAC.h)Manager Section.

Item	Functions	Description
01	DrvDAC_OPEN	Open the DAC
02	DrvDAC_CLOSE	Close the DAC
03	DrvDAC_ENABLE	Enable the DAC
04	DrvDAC_DISABLE	Disable the DAC
05	DrvDAC_OUTPUT_ENABLE	DAC output enable
06	DrvDAC_OUTPUT_DISABLE	DAC output disable
07	DrvDAC_P_INPUT	DAC positive reference input selection.
08	DrvDAC_N_INPUT	DAC negative reference input selection
09	DrvDAC_DAO_BIT	DAO[7:0] buffer from MSB to LSB
10	DrvDAC_SetoutputIO	Set output pin of DAC

12.2 The block diagram of 8-bit Resistance Ladders

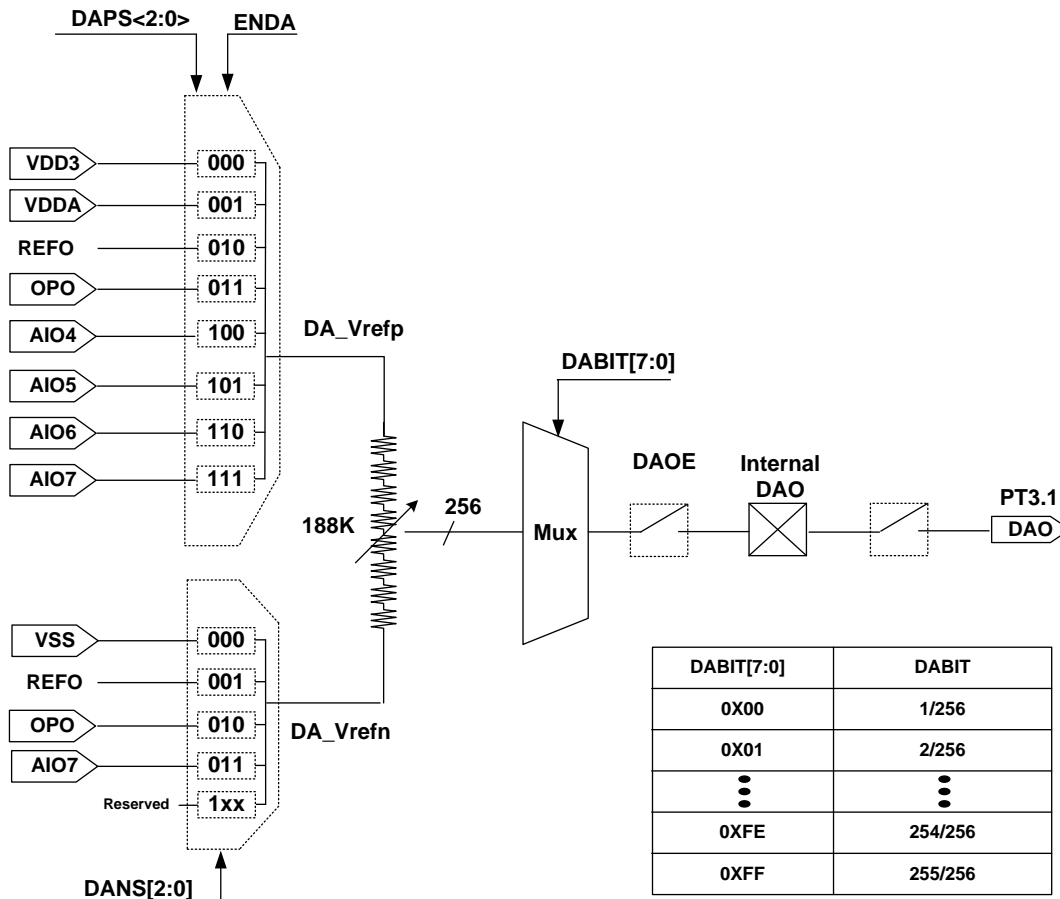

12.3 Type Definition

E_DAC_INPUT

Enumeration identifier	Value	Description
E_DAC_PVDD3V	0x0	Signal input for positive
E_DAC_PVDDA	0x1	Signal input for positive
E_DAC_PREFO_I	0x2	Signal input for positive
E_DAC_POPO	0x3	Signal input for positive
E_DAC_PAIO4	0x4	Signal input for positive
E_DAC_PAIO5	0x5	Signal input for positive
E_DAC_PAIO6	0x6	Signal input for positive
E_DAC_PAIO7	0x7	Signal input for positive
E_DAC_NVSSA	0x0	Signal input for negative
E_DAC_NREFO_I	0x1	Signal input for negative
E_DAC_NOPO	0x2	Signal input for negative
E_DAC_NAIO7	0x3	Signal input for negative

12.4 Functions

12.4.1 DrvDAC_OPEN

- **Prototype**

unsigned int DrvDAC_Open(E_DAC_INPUT uPininput ,E_DAC_INPUT uNinput, uDAO)

- **Description**

Enable the DAC , select positive and negative reference input, set the initial scale value of DAC output voltage.

Configure the register 0x41700[7:0], 0x41704[7:0].

- **Parameter**

uPininput [in] DAC positive reference input selection.

0 : VDD

1 : VDDA

2 : REFO_I

4: AIO4

5: AIO5

6: AIO6

7: AIO7

uNinput [in] DAC negative reference input selection.

0 : VSSA

1 : REFO_I

2 : AIO6

3 : AIO7

uDAO [in] the scale value of output voltage DAO/255

DAO[7:0]buffer from MSB to LSB

- **Include**

Peripheral_lib/DrvDAC.h

- **Return Value**

0: Operation successful

Other : Incorrect argument

- **Example**

```
/* Enable DAC, Select positive reference input=AIO6, negative reference input=VSSA ,DAO=5 */
```

```
DrvDAC_Open (E_DAC_AIO6, E_DAC_VSSA ,5 );
```

12.4.2 DrvDAC_CLOSE

- **Prototype**

void DrvDAC_Close(void)

- **Description**

Close the DAC (ENDA and DAOE off)

Configure the register 0X41700 [1:0]

- **Parameter**

None

- **Include**

Peripheral_lib/DrvDAC.h

- **Return Value**

None

- **Example**

```
/* Close DAC */
```

```
DrvDAC_Close ();
```

12.4.3 DrvDAC_ENABLE

- **Prototype**

void DrvDAC_Enable(void)

- **Description**

Enable DAC (ENDA enable)

Configure the register 0X41700 [0]

- **Parameter**

None

- **Include**

Peripheral_lib/DrvDAC.h

- **Return Value**

None

- **Example**

```
/* Close DAC */
```

```
DrvDAC_Enable();
```

12.4.4 DrvDAC_DISABLE

- **Prototype**

void DrvDAC_Disable(void)

- **Description**

Close the DAC (ENDA disable)

Configure the register 0X41700 [0]

- **Parameter**

None

- **Include**

Peripheral_lib/DrvDAC.h

- **Return Value**

None

- **Example**

```
/* Close DAC */  
DrvDAC_Close ();
```

12.4.5 DrvDAC_OUTPUT_ENABLE

- **Prototype**

```
void DrvDAC_EnableOutput(void)
```

- **Description**

DAC output enable (DAOE enable)
Configure the register 0X41700[1]

- **Parameter**

None

- **Include**

Peripheral_lib/DrvDAC.h

- **Return Value**

None

- **Example**

```
/* DAC output enable */  
DrvDAC_EnableOutput ();
```

12.4.6 DrvDAC_OUTPUT_DISABLE

- **Prototype**

```
void DrvDAC_DisableOutput (void)
```

- **Description**

DAC output disable(DAOE disable)
Configure the register 0X41700 [1]

- **Parameter**

None

- **Include**

Peripheral_lib/DrvDAC.h

- **Return Value**

None

- **Example**

```
/* DAC output disable */  
DrvDAC_DisableOutput();
```

12.4.7 DrvDAC_P_INPUT

- **Prototype**

unsigned int DrvDAC_Pinput(E_DAC_INPUT uPininput)

- **Description**

DAC positive reference input selection.

Configure the register 0X41700 [6:4]

- **Parameter**

uPininput [in] DAC positive reference input selection.

0 : VDD3V

1 : VDDA

2 : REFO_I

3 : OPO

4: AIO4

5: AIO5

6: AIO6

7: AIO7

- **Include**

Peripheral_lib/DrvDAC.h

- **Return Value**

0: Operation successful

Other : Incorrect argument

- **Example**

```
/* Select DAC positive reference input from VDD3V. */  
DrvDAC_Pinput (E_DAC_VDD3V);
```

12.4.8 DrvDAC_N_INPUT

- **Prototype**

unsigned int DrvDAC_Ninput(E_DAC_INPUT uNinput)

- **Description**

DAC negative reference input selection.

Configure the register 0X41700 [3:2]

- **Parameter**

uNinput [in] DAC negative reference input selection.

0 : VSSA

1 : REFO_I

2 : AIO6

3 : AIO7

- **Include**

Peripheral_lib/DrvDAC.h

- **Return Value**

0: Operation successful

Other : Incorrect argument

- **Example**

```
/* Select DAC negative reference input from VSSA. */
```

```
DrvDAC_Ninput (E_DAC_VSSA);
```

12.4.9 DrvDAC_DAO_BIT

- **Prototype**

```
unsigned int DrvDAC_DABIT(uDABIT)
```

- **Description**

DAO[7:0] the scale of output voltage :DAO/255

Configure the register 0X41704[7:0]

- **Parameter**

uDABIT [in]

the scale of output voltage :uDABIT/255

- **Include**

Peripheral_lib/DrvDAC.h

- **Return Value**

0: Operation successful

Other : Incorrect argument

- **Example**

```
/* DAO [7:0] =5 */
```

```
DrvDAC_DABIT(5);
```

12.4.10 DrvDAC_SetoutputIO

- **Prototype**

unsigned int DrvDAC_SetoutputIO(unsigned int uio)

- **Description**

DAO Output to PT3.1 enable

Configure the register 0X40828[17]

- **Parameter**

uio [in]

0 disable DAO Output to PT3.1

1 enable DAO Output to PT3.1

- **Include**

Peripheral_lib/DrvDAC.h

- **Return Value**

0: Operation successful

1 : Incorrect argument

- **Example**

```
/* enable DAO Output to PT3.1*/
```

```
DrvDAC_SetoutputIO(1);
```

13. RTC Driver

13.1 Introduction

The following functions are included in RTC Manager Section.

Item	Functions	Description
01	DrvRTC_SetFrequencyCompensation	Set Frequency Compensation Data
02	DrvRTC_WriteEnable	Access Password to KEY to make access other register enable
03	DrvRTC_Disable	Clear the RTC KEY to make the RTC register can not write
04	DrvRTC_ClockSource	Select clock source from the external or internal.
05	DrvRTC_AlarmEnable	Enable the TAEn.
06	DrvRTC_AlarmDisable	Disable the TAEn.
07	DrvRTC_PeriodicTimeEnable	Enable PTEn and set periodic timer frequency of RTC.
08	DrvRTC_PeriodicTimeDisable	Disable the PTEn.
09	DrvRTC_Enable	Enable the RTCEn.
10	DrvRTC_Disable	Disable the RTCEn.
11	DrvRTC_HourFormat	Set the clock for 12 or 24hour
12	DrvRTC_ReadState	Read the RTC state
13	DrvRTC_ClearFlagState	Clear the RTC state
14	DrvRTC_EnableInt	RTC Interrupt Enable
15	DrvRTC_DisableInt	RTC Interrupt disable
16	DrvRTC_ReadIntFlag	Read the RTC Interrupt flag.
17	DrvRTC_ClearIntFlag	Clear the RTC Interrupt flag.
18	DrvRTC_Write	Set current date/time or alarm date/time to RTC
19	DrvRTC_Read	Read current date/time or alarm date/time from RTC setting
20	DrvRTC_ClkConfig	Set RTC clock source

13.2 The block diagram of RTC

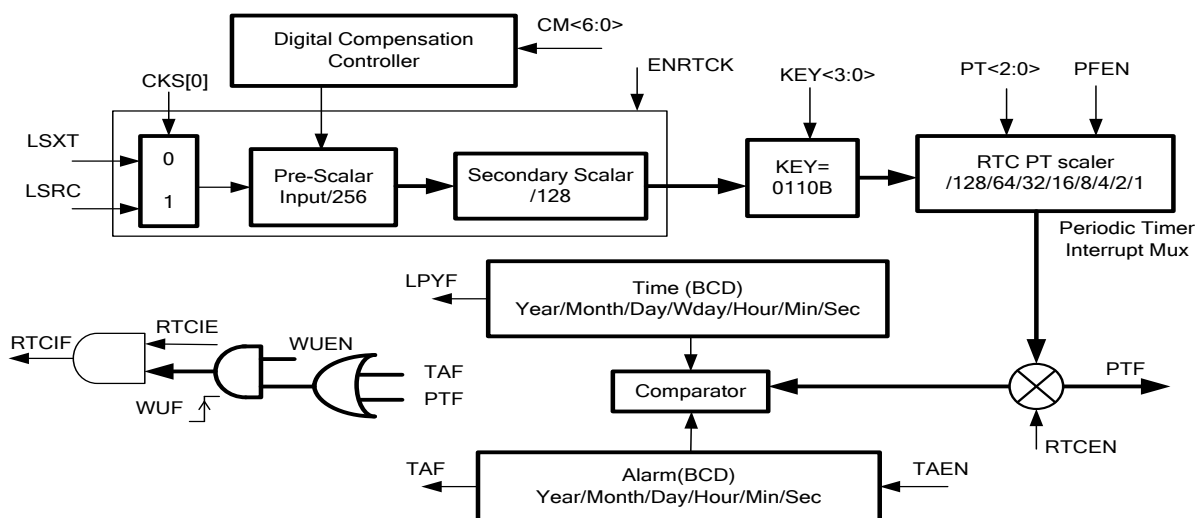

13.3 Type Definition

E_DRVRTC_CLOCK_SOURCE

Enumeration Identifier	Value	Description
E_EXT_CK	0	RTC clock source from external low speed crystal source
E_INT_CK	1	RTC clock source from internal low speed crystal source

E_DRVRTC_TICK

Enumeration Identifier	Value	Description
E_DRVRTC_1_128_SEC	0	Set tick period 1/128 tick per second
E_DRVRTC_1_64_SEC	1	Set tick period 1/64 tick per second
E_DRVRTC_1_32_SEC	2	Set tick period 1/32 tick per second
E_DRVRTC_1_16_SEC	3	Set tick period 1/16 tick per second
E_DRVRTC_1_8_SEC	4	Set tick period 1/8 tick per second
E_DRVRTC_1_4_SEC	5	Set tick period 1/4 tick per second
E_DRVRTC_1_2_SEC	6	Set tick period 1/2 tick per second
E_DRVRTC_1_SEC	7	Set tick period 1 tick per second

E_DRVRTC_HOUR_FORMAT

Enumeration Identifier	Value	Description
E_DRVRTC_HOUR_12	1	The hour format by 12
E_DRVRTC_HOUR_24	0	The hour format by 24

E_DRVRTC_TIME_SELECT

Enumeration Identifier	Value	Description
DRVRTC_CURRENT_TIME	0	Select current time option
DRVRTC_ALARM_TIME	1	Select alarm time option

E_DRVRTC_FLAG

Enumeration Identifier	Value	Description
E_DRVRTC_ALARM_FLAG	0	alarm flag
E_DRVRTC_PERIODIC_FLAG	1	periodic timer flag
E_DRVRTC_CLEAR_ALL	2	clear alarm flag and periodic timer flag

13.4 Functions

Note : It is necessary to enable RTC clock and write <0110> in the RTKEY before writing data into the RTC register

13.4.1 DrvRTC_SetFrequencyCompensation

- **Prototype**

```
unsigned int DrvRTC_SetFrequencyCompensation(  
    unsigned int uFrequencyCom );
```

- **Description**

Set Frequency Compensation Data
Configure the register 0X41A04[22:16]

- **Parameters**

uFrequencyCom [in] specified RTC clock frequency compensation, It could be 0~0x7f

01111111 : +126 ppm
01111110 : +124 ppm
|:
00000001 : +2 ppm
00000000 : +0 ppm
10000000 : - 0 ppm
10000001 : - 2 ppm
|:
11111110 : -124 ppm
11111111 : -126 ppm

- **Include**

Peripheral_lib/DrvRTC.h

- **Return Value**

0: Operation successful
Other : Incorrect argument

- **Example**

```
/* Compensation deviation -2 PPM */  
DrvRTC_SetFrequencyCompensation (0x41);
```

13.4.2 DrvRTC_WriteEnable

- **Prototype**

```
void DrvRTC_WriteEnable(void);
```

- **Description**

Access Password to KEY to make access other register enable.

Configure the register 0X41a00[23:20]

- **Parameters**

None

- **Include**

Peripheral_lib/DrvRTC.h

- **Return Value**

None.

- **Example**

```
/* Unlock RTC register, the RTC registers can write */  
DrvRTC_WriteEnable ();
```

13.4.3 DrvRTC_WriteDisable

- **Prototype**

```
void DrvRTC_WriteDisable(void);
```

- **Description**

Clear the RTC KEY to make the RTC register can not write
Configure the register 0X41A00[23:20]=0000b

- **Parameters**

None

- **Include**

Peripheral_lib/DrvRTC.h

- **Return Value**

None.

- **Example**

```
/* Lock RTC register, the RTC registers can not write */  
DrvRTC_WriteDisable ();
```

13.4.4 DrvRTC_ClockSource

- **Prototype**

```
unsigned int DrvRTC_ClockSource(  
E_DRVRTC_CLOCK_SOURCE uClockSource  
);
```

- **Description**

Select clock source from the external or internal.
Configure the register 0X41A00[1]

- **Parameters**

uClockSource [in]

0 : E_EXT_CK

1 : E_INT_CK

- **Include**

Peripheral_lib/DrvRTC.h

- **Return Value**

CKS has a foolproof protection

0 : E_EXT_CK

1 : E_INT_CK

- **Example**

```
/* Select the RTC Clock from external. */
```

```
DrvRTC_ClockSource(E_EXT_CK);
```

13.4.5 DrvRTC_AlarmEnable

- **Prototype**

```
void DrvRTC_AlarmEnable (void);
```

- **Description**

Enable the TAEn.

Configure the register 0X41A00[23]

- **Parameters**

none

- **Include**

Peripheral_lib/DrvRTC.h

- **Return Value**

none

- **Example**

```
/* Enable RTC alarm */
```

```
DrvRTC_AlarmEnable ();
```

13.4.6 DrvRTC_AlarmDisable

- **Prototype**

```
void DrvRTC_AlarmDisable (void);
```

- **Description**

Disable the TAEn.

Configure the register 0X41A00[3]

- **Parameters**

none

- **Include**

Peripheral_lib/DrvRTC.h

- **Return Value**

none

- **Example**

```
/* Disable Alarm*/
```

```
DrvRTC_AlarmDisable();
```

13.4.7 DrvRTC_PeriodicTimeEnable

- **Prototype**

```
unsigned int DrvRTC_PeriodicTimeEnable (E_DRVRTC_TICK uPeriodicTimer);
```

- **Description**

Enable PTEn and set periodic timer frequency of RTC.

Configure the register 0X41A04[2:0],0X41A00[5]=1,0X41A00[4]=1.

- **Parameters**

uPeriodicTimer[in]

0: 1/128Second

1: 1/64Second

2: 1/32Second

3: 1/16Second

4: 1/8Second

5: 1/4Second

6: 1/2Second

7: 1Second

- **Include**

Peripheral_lib/DrvRTC.h

- **Return Value**

0: Operation successful

Other : Incorrect argument

- **Example**

```
/* Enable RTC alarm and select 1/16 second */
```

```
DrvRTC_PeriodicTimeEnable (3);
```

13.4.8 DrvRTC_PeriodicTimeDisable

- **Prototype**

void DrvRTC_PeriodicTimeDisable (void);

- **Description**

Disable the PTEn.

Configure the register 0X41A00[5]=0 / 0X41A00[4]=0

- **Parameters**

none

- **Include**

Peripheral_lib/DrvRTC.h

- **Return Value**

none

- **Example**

```
/* Disable the PTEn*/
```

```
DrvRTC_PeriodicTimeDisable();
```

13.4.9 DrvRTC_Enable

- **Prototype**

void DrvRTC_Enable (void);

- **Description**

Enable the RTCEn.

Configure the register 0X41A00[0]

- **Parameters**

none

- **Include**

Peripheral_lib/DrvRTC.h

- **Return Value**

none

- **Example**

```
/* Enable the RTC */
```

```
DrvRTC_Enable ();
```

13.4.10 DrvRTC_Disable

- **Prototype**

void DrvRTC_Disable (void);

- **Description**

Disable the RTCEn.

Configure the register 0X41A00[0]

- **Parameters**

none

- **Include**

Peripheral_lib/DrvRTC.h

- **Return Value**

none

- **Example**

```
/* Disable the RTC */  
DrvRTC_Disable();
```

13.4.11 DrvRTC_HourFormat

- **Prototype**

```
unsigned int DrvRTC_HourFormat(E_DRVRTC_HOUR_FORMAT uHourFormat);
```

- **Description**

Set the clock for 12 or 24hour

Configure the register 0X41A00[2]

- **Parameters**

1 : The hour format by 12

0 : The hour format by 24

- **Include**

Peripheral_lib/DrvRTC.h

- **Return Value**

0: Operation successful

Other : Incorrect argument

- **Example**

```
/* Set 24-hour */  
DrvRTC_DrvRTC_HourFormat (0);
```

13.4.12 DrvRTC_ReadState

- **Prototype**

```
unsigned int DrvRTC_ReadState(void);
```

- **Description**

Read the RTC state

Configure the register 0X41A00[19:16]

- **Parameters**

none

- **Include**

Peripheral_lib/DrvRTC.h

- **Return Value**

Return 0x0~0xf

Bit 0 : RTC Alarm Flag

Bit 1 : RTC Wakeup Flag

Bit 2 : RTC Aperiodic Timer Flag

Bit 3 : RTC Leap Year Flag

- **Example**

```
/* Check the RTC of alarm flag */  
If (DrvRTC_DrvRTC_ReadState&0x1)  
//RTC alarm triggered  
else  
// RTC Wakeup triggered
```

13.4.13 DrvRTC_ClearState

- **Prototype**

unsigned int DrvRTC_ClearState(E_DRVRTC_FLAG uFlag);

- **Description**

Clear the RTC state

Clear the register 0X41A00[19:16]

- **Parameters**

0 : clear alarm flag

1 : clear periodic timer flag

2: clear alarm flag and periodic timer flag

- **Include**

Peripheral_lib/DrvRTC.h

- **Return Value**

0: Operation successful

Other : Incorrect argument

- **Example**

```
/* Clear TAF/ PTF flag */  
DrvRTC_ClearState(2);
```

13.4.14 DrvRTC_EnableInt

- **Prototype**

void DrvRTC_EnableInt(void)

- **Description**

RTC Interrupt Enable. Need to clear the PTF after response to interrupt, then it can respond to interrupt normally next time.

Configure the register 0X40004[21]

- **Parameter**

None

- **Include**

Peripheral_lib/DrvRTC.h

- **Return Value**

None

- **Example**

```
/* Enable RTC interrupt */  
DrvRTC_EnableInt ();
```

13.4.15 DrvRTC_DisableInt

- **Prototype**

void DrvRTC_DisableInt(void)

- **Description**

RTC Interrupt disable

Configure the register 0X40004[21]

- **Parameter**

None

- **Include**

Peripheral_lib/DrvRTC.h

- **Return Value**

None

- **Example**

```
/* Disable RTC interrupt */  
DrvRTC_DisableInt ();
```

13.4.16 DrvRTC_ReadIntFlag

- **Prototype**

unsigned int DrvRTC_ReadIntFlag(void)

- **Description**

Read the RTC Interrupt flag.

Configure the register 0X40004[5]

- **Parameter**

None

- **Include**

Peripheral_lib/DrvRTC.h

- **Return Value**

0 : Normal

1 :Interrupted

- **Example**

```
/* Read the RTC Interrupt flag */
```

```
Unsigned char flag; flag=DrvRTC_ReadIntFlag();
```

13.4.17 DrvRTC_ClearIntFlag

- **Prototype**

```
void DrvRTC_ClearIntFlag(void)
```

- **Description**

Clear the RTC Interrupt flag.

Configure the register 0X40004[5]

- **Parameter**

None

- **Include**

Peripheral_lib/DrvRTC.h

- **Return Value**

None

- **Example**

```
/* Clear the RTC Interrupt flag */
```

```
DrvRTC_ClearIntFlag();
```

13.4.18 DrvRTC_Write

- **Prototype**

```
Unsigned int DrvRTC_Write (
```

```
E_DRVRTC_TIME_SELECT eTime, S_DRVRTC_TIME_DATA_T *sPt );
```

- **Description**

Set current date/time or alarm date/time to RTC

Configure the register 0X41A08/0X41A0C/0X41A10/0X41A14/0X41A18/0X41A1C

- **Parameter**

eTime [in] Specify the current/alarm time to be written.
0 : Current time
1 : Alarm time
*sPt [in] Specify the data to write to RTC. It includes:
u8cClockDisplay DRVRTC_CLOCK_12(00:00~11:59) / DRVRTC_CLOCK_24(00:00~23:59)
u8cAmPm DRVRTC_AM / DRVRTC_PM
u32cSecond Second value
u32cMinute Minute value
u32cHour Hour value
u32cDayOfWeek Day of week
u32cDay Day value
u32cMonth Month value
u32Year Year value

- **Include**

Peripheral_lib/DrvRTC.h

- **Return Value**

0: Operation successful
Other : Incorrect argument

- **Example**

```
/* Condition: Update current the second of time to zero */  
S_DRVRTC_TIME_DATA_T sCurTime;  
DrvRTC_Read(DRVRTC_ALARM_TIME, &sCurTime);  
sCurTime.u32cSecond = 0;  
DrvRTC_Write(DRVRTC_ALARM_TIME, &sCurTime);
```

13.4.19 DrvRTC_Read

- **Prototype**

```
unsigned int DrvRTC_Read (  
E_DRVRTC_TIME_SELECT eTime,  
S_DRVRTC_TIME_DATA_T *sPt );
```

- **Description**

Read current date/time or alarm date/time from RTC setting
Configure the register 0X41A08/0X41A0C/0X41A10/0X41A14/0X41A18/0X41A1C

- **Parameter**

eTime [in] Specify the current/alarm time to be written.
0 : Current time
1 : Alarm time

*sPt [in]	Specify the data to write to RTC. It includes:
u8cClockDisplay	DRVRTC_CLOCK_12 / DRVRTC_CLOCK_24
u8cAmPm	DRVRTC_AM / DRVRTC_PM
u32cSecond	Second value
u32cMinute	Minute value
u32cHour	Hour value
u32cDayOfWeek	Day of week
u32cDay	Day value
u32cMonth	Month value
u32Year	Year value

- **Include**

Peripheral_lib/DrvRTC.h

- **Return Value**

0: Operation successful
Other : Incorrect argument

- **Example**

```
/* Condition: You want to get current RTC calendar and time */  
S_DRVRTC_TIME_DATA_T sCurTime;  
DrvRTC_Read(DRVRTC_CURRENT_TIME, &sCurTime);
```

13.4.20 DrvRTC_ClkConfig

- **Prototype**

unsigned char DrvRTC_ClkConfig(unsigned char uclken)

- **Description**

RTC Interrupt disable
Configure the register 0X40308[23]

- **Parameter**

uClockSource [in]
0 : disable the clock source
1 : enable the clock source

- **Include**

Peripheral_lib/DrvRTC.h

- **Return Value**

1: Operation successful
0 : Incorrect argument

- **Example**

```
/* enable the clock source */  
DrvRTC_ClkConfig(1);
```

14. I2C Driver

14.1 Introduction

The following functions are included in I2C Manager Section.

Item	Functions	Description
01	DrvI2C_Open	Enable the I2C and configure the I2C bus clock
02	DrvI2C_Close	Disable the I2C
03	DrvI2C_SlaveSet	Enable slave mode , set address , choose whether to enable GC
04	DrvI2C_SetIOPin	Select IO port as IIC port
05	DrvI2C_WriteData	To set a byte of data to be sent.
06	DrvI2C_Write3ByteData	To set a 3byte of data to be sent.
07	DrvI2C_ReadData	Read the data form receiver data buffer.
08	DrvI2C_Ctrl	To set I2C control bit include STA, STO, AA, SI in control register.
09	DrvI2C_EnableInt	Enable the I2C Interrupt
10	DrvI2C_DisableInt	Disable the I2C Interrupt
11	DrvI2C_ReadIntFlag	Read the I2C Interrupt flag.
12	DrvI2C_ClearIntFlag	Clear the I2C Interrupt flag.
13	DrvI2C_ClearEIRQ	Clear the EIRQ
14	DrvI2C_ClearIRQ	Clear the IRQ.
15	DrvI2C_GetStatusFlag	Take status flags
16	DrvI2C_TimeOutEnable	Enable TimeOut , set clock pre scale and time out limit
17	DrvI2C_TimeOutDisable	Disable the Timeout
18	DrvI2C_STSP	Generate the START or STOP singal from IIC bus
19	DrvI2C_MGetACK	Check the ACK from slaver during the set time
20	DrvI2C_DisableIOPin	Disable IIC communication function of the IO port

14.2 The block diagram of IIC

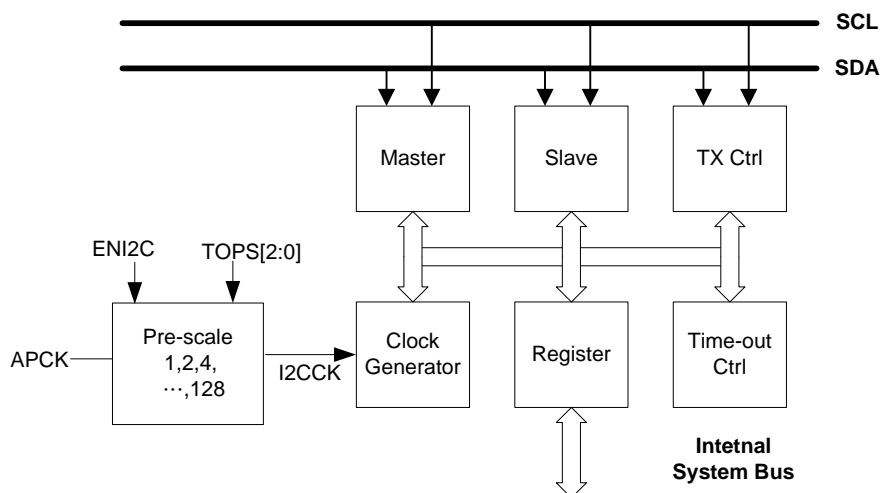

14.3 Type Definition

E_DRVI2C_Status

Enumeration Identifier	Value	Description
E_DRVI2C_ARBITRATION_FLAG	0	Arbitration Lost Flag
E_DRVI2C_GENERAL_CALL_FLAG	1	General Call Flag
E_DRVI2C_ACKNOWLEDGE_FLAG	2	Acknowledge Flag
E_DRVI2C_DATA_FIELD_FLAG	3	Data Field Flag
E_DRVI2C_RW_STATE_FLAG	4	Read/Write State Flag
E_DRVI2C_RS_FLAG	5	Received Stop/Repeat-Start Flag
E_DRVI2C_SLAVE_ACTIVE_FLAG	6	Slave Mode Active Flag
E_DRVI2C_MASTER_ACTIVE_FLAG	7	Master Mode Active Flag

E_DRVI2C_TIMEOUT_PRESCALE

Enumeration Identifier	Value	Description
E_DRVI2C_I2CLK_DIV_1	0	I2C CLK/1
E_DRVI2C_I2CLK_DIV_2	1	I2C CLK/2
E_DRVI2C_I2CLK_DIV_4	2	I2C CLK/4
E_DRVI2C_I2CLK_DIV_8	3	I2C CLK/8
E_DRVI2C_I2CLK_DIV_16	4	I2C CLK/16
E_DRVI2C_I2CLK_DIV_32	5	I2C CLK/32
E_DRVI2C_I2CLK_DIV_64	6	I2C CLK/64
E_DRVI2C_I2CLK_DIV_128	7	I2C CLK/128

E_DRVI2C_TIMEOUT_LIMIT

Enumeration Identifier	Value	Description
E_DRVI2C_CLKPSX1	0	1 * CLKps Cycle
E_DRVI2C_CLKPSX2	1	2 * CLKps Cycle
E_DRVI2C_CLKPSX3	2	3 * CLKps Cycle
E_DRVI2C_CLKPSX4	3	4 * CLKps Cycle
E_DRVI2C_CLKPSX5	4	5 * CLKps Cycle
E_DRVI2C_CLKPSX6	5	6 * CLKps Cycle
E_DRVI2C_CLKPSX7	6	7 * CLKps Cycle
E_DRVI2C_CLKPSX8	7	8 * CLKps Cycle
E_DRVI2C_CLKPSX9	8	9 * CLKps Cycle
E_DRVI2C_CLKPSX10	9	10 * CLKps Cycle
E_DRVI2C_CLKPSX11	10	11 * CLKps Cycle
E_DRVI2C_CLKPSX12	11	12 * CLKps Cycle
E_DRVI2C_CLKPSX13	12	13 * CLKps Cycle
E_DRVI2C_CLKPSX14	13	14 * CLKps Cycle
E_DRVI2C_CLKPSX15	14	15 * CLKps Cycle
E_DRVI2C_CLKPSX16	15	16 * CLKps Cycle

E_DRVI2C_INTERRUPT

Enumeration Identifier	Value	Description
E_DRVI2C_INT	1	I2C Interrupt enable
E_DRVI2C_ERROR_INT	2	I2C error Interrupt enable
E_DRVI2C_INT_ALL	3	enable I2C interrupt and error interrupt

E_DRVI2C_SLAVE_BIT

Enumeration Identifier	Value	Description
E_DRVI2C_SLAVE_7BIT	0	Slave 7bit address mode

E_DRVI2C_SLAVE_10BIT	1	Slave 10bit address mode
----------------------	---	--------------------------

14.4 Functions

Note : Configure the IIC register after enable IIC

14.4.1 DrvI2C_Open

- **Prototype**

unsigned int DrvI2C_Open (uint32_t u32CRG);

- **Description**

Enable the I2C and configure the I2C bus clock

Configure the register 0X41000[0]=1, 0X41008[23:16]

- **Parameters**

u32CRG [in] Set CRG value. It could be 0~0xff.

Data Baud Rate = (I2CLK/(4*(CRG+1)))

- **Include**

Peripheral_lib/DrvI2C.h

- **Return Value**

0: Operation successful

Other : Incorrect argument

- **Example**

```
/* Enable I2C and set CRG value 100 */
```

```
DrvI2C_Open (100);
```

14.4.2 DrvI2C_Close

- **Prototype**

void DrvI2C_Close (void);

- **Description**

Disable the I2C.

Configure the register 0X41000[0]

- **Parameters**

None

- **Include**

Peripheral_lib/DrvI2C.h

- **Return Value**

None.

- **Example**

```
/* Close the I2C */
```

```
DrvI2C_Close ();
```

14.4.3 DrvI2C_SlaveSet

● Prototype

```
unsigned int DrvI2C_SlaveSet(  
uint32_t uSlaveAddr,  
E_DRVI2C_SLAVE_BIT uAddrBit,  
uint8_t uSlave3Byte,  
uint8_t GC_Flag);
```

● Description

Enable slave mode, and set the location address, and choose whether to enable GC
Configure the register 0X41004[7] /.0X41004[5] , 0X41000[2], 0X4100C[7:0]

● Parameters

uSlaveAddr : slaver address
7bit : 0~0x7f
10bit: 0~0x3ff
uAddrBit : slaver address mode
0: Slave 7bit address mode
1: Slave 10bit address mode
uSlave3Byte: Slave 3 Byte Data Mode Enable control
0: Normal
1:Slave 3byte Data transfer
GC_Flag: general call flag
0: Normal
1:Enable general call

● Include

Peripheral_lib/DrvI2C.h

● Return Value

1: Operation successful
Other : Incorrect argument

● Example

```
/* Enable Slave mode, position setting 0x30*/  
DrvI2C_SlaveSet (0x30,0,0,0);
```

14.4.4 DrvI2C_SetIOPin

- **Prototype**

unsigned char DrvI2C_SetIOPin(unsigned int upin)

- **Description**

Set IO port of I2C

Configure the register 0X40844[19:16]

- **Parameters**

Upin[in] select IO port as I2C port

0 SCL=PT1.0;SDA=PT1.1

1 SCL=PT1.2;SDA=PT1.3

2 SCL=PT1.4;SDA=PT1.5

3 SCL=PT1.6;SDA=PT1.7

4 SCL=PT2.0;SDA=PT2.1

5 SCL=PT2.2;SDA=PT2.3

6 SCL=PT2.4;SDA=PT2.5

7 SCL=PT2.6;SDA=PT2.7

- **Include**

Peripheral_lib/DrvI2C.h

- **Return Value**

None

- **Example**

```
/* specify PT1.0 and PT1.1 */
```

```
DrvI2C_SetIOPin(0);
```

14.4.5 DrvI2C_WriteData

- **Prototype**

void DrvI2C_WriteData(uint8_t uData);

- **Description**

To set a byte of data to be sent.

Configure the register 0X41014[7:0]

- **Parameters**

uData [IN] the data to be sent

1 Byte data

- **Include**

Peripheral_lib/DrvI2C.h

- **Return Value**

None

- **Example**

```
/* Set byte data 0x55 into transmitter data buffer register */  
DrvI2C_WriteData (0x55);
```

14.4.6 DrvI2C_Write3ByteData

- **Prototype**

```
void DrvI2C_Write3ByteData(uint8_t uData1,uData2,uData3);
```

- **Description**

To set a 3byte of data to be sent.
Configure the register 0X41014

- **Parameters**

uData1, uData2, uData3 [IN]
Byte data

- **Include**

Peripheral_lib/DrvI2C.h

- **Return Value**

None

- **Example**

```
/* Set 3byte data 0x11 0x22 0x33 into transmitter data buffer register */  
DrvI2C_Write3ByteData(0x11,0x22,0x33);
```

14.4.7 DrvI2C_ReadData

- **Prototype**

```
unsigned char DrvI2C_ReadData(void);
```

- **Description**

Read the data form receiver data buffer.
Configure the register 0X41010[7:0]

- **Parameters**

None

- **Include**

Peripheral_lib/DrvI2C.h

- **Return Value**

1 Byte received

- **Example**

```
/* Read byte data from receiver data buffer */  
DrvI2C_ReadData();
```

14.4.8 DrvI2C_Ctrl

- **Prototype**

```
void DrvI2C_Ctrl(uint8_t start, uint8_t stop, uint8_t intFlag, uint8_t ack);
```

- **Description**

To set I2C control bit include STA, STO, AA, SI in control register.

Configure the register 0X41004[3:0]

- **Parameters**

start [in]:

To set STA bit or not. (1: set, 0: don't set). If the STA bit is set, a START or repeat START signal will be generated when I2C bus is free.

stop [in]:

To set STO bit or not. (1: set, 0: don't set). If the STO bit is set, a STOP signal will be generated. When a STOP condition is detected, this bit will be cleared by hardware automatically.

intFlag [in]:

To clear SI flag (I2C interrupt flag). (1: clear, 0: don't work)

ack [in]:

To enable AA bit (Assert Acknowledge control bit) or not. (1: enable, 0: disable)

- **Include**

```
Peripheral_lib/DrvI2C.h
```

- **Return Value**

Byte data

- **Example**

```
DrvI2C_Ctrl (I2C_PORT0, 0, 0, 1, 0); /* Set I2C SI bit to clear SI flag */
```

```
DrvI2C_Ctrl (I2C_PORT0, 1, 0, 0, 0); /* Set I2C STA bit to send START signal */
```

14.4.9 DrvI2C_EnableInt

- **Prototype**

```
void DrvI2C_EnableInt(E_DRVI2C_INTERRUPT uINT)
```

- **Description**

Enable the I2C Interrupt

Configure the register 0X40000[21:20]

- **Parameter**

uINT[IN]

- 0 : I2C Interrupt enable
- 1 : I2C error Interrupt enable
- 2 : enable I2C interrupt and error interrupt

- **Include**

Peripheral_lib/DrvI2C.h

- **Return Value**

None

- **Example**

```
/* Enable I2C interrupt */  
DrvI2C_EnableInt(1);
```

14.4.10 DrvI2C_DisableInt

- **Prototype**

```
void DrvI2C_DisableInt(E_DRVI2C_INTERRUPT uINT)
```

- **Description**

Disable the I2C Interrupt
Configure the register 0X40000[21:20]

- **Parameter**

uINT[IN]
0: I2C Interrupt disable
1 : I2C error Interrupt disable
2 : disable I2C interrupt and error interrupt

- **Include**

Peripheral_lib/DrvI2C.h

- **Return Value**

None

- **Example**

```
/* Disable I2C interrupt */  
DrvI2C_DisableInt(1);
```

14.4.11 DrvI2C_ReadIntFlag

- **Prototype**

```
E_DRVI2C_INTERRUPT DrvI2C_ReadIntFlag(void)
```

- **Description**

Read the I2C Interrupt flag.
Read the register 0X40000[5:4]

- **Parameter**

None

- **Include**

Peripheral_lib/DrvI2C.h

- **Return Value**

0: no I2C IRQ

1 : I2C Interrupt flag is true

2 : I2C error Interrupt flag is true

3 : enable I2C interrupt and error interrupt of flag is true

- **Example**

```
/* Read the I2C Interrupt flag */  
uint32_t temp;  
temp=DrvI2C_ReadIntFlag();
```

14.4.12 DrvI2C_ClearIntFlag

- **Prototype**

```
void DrvRTC_ClearIntFlag(E_DRVI2C_INTERRUPT uINT)
```

- **Description**

Clear the RTC Interrupt flag.

Clear the register 0X40000[5:4]

- **Parameter**

uINT[IN]

0 : Clear the I2C Interrupt flag

1 : Clear the I2C error Interrupt flag

2 : Clear the I2C interrupt and error flag

- **Include**

Peripheral_lib/DrvI2C.h

- **Return Value**

None

- **Example**

```
/* Clear the I2C Interrupt flag */  
DrvI2C_ClearIntFlag(0);
```

14.4.13 DrvI2C_ClearEIRQ

- **Prototype**

```
void DrvI2C_ClearEIRQ(void)
```

- **Description**

Clear the EIRQ.

Note :The EIRQ flag can be clear after clear the TOPFLAG. The I2CEIF can be clear after clear the EIRQ flag. Write 0 to this bit to clear EIRQ.

Configure the register 0X41004[4]

- **Parameter**

None

- **Include**

Peripheral_lib/DrvI2C.h

- **Return Value**

None

- **Example**

```
/* Clear the EIRQ */  
DrvI2C_ClearEIRQ ();
```

14.4.14 DrvI2C_ClearIRQ

- **Prototype**

```
void DrvI2C_ClearIRQ(void)
```

- **Description**

Clear the IRQ.

The IRQFlag will be set 1 when receive 9th clock, and SCL will be pull down until clear IRQFlag

Configure the register 0X41004[1]

- **Parameter**

None

- **Include**

Peripheral_lib/DrvI2C.h

- **Return Value**

None

- **Example**

```
/* Clear the IRQ */  
DrvI2C_ClearIRQ ();
```

14.4.15 DrvI2C_GetStatusFlag

- **Prototype**

```
unsigned char DrvI2C_GetStatusFlag(void)
```

- **Description**

Take status flags

Read the register 0X41004[23:16]

- **Parameter**

None

- **Include**

Peripheral_lib/DrvI2C.h

- **Return Value**

The meaning of each bit for the return value:

Bit 0 : Arbitration Lost Flag

Bit 1: General Call Flag

Bit 2: Acknowledge Flag

Bit 3: Data Field Flag

Bit 4: Read/Write State Flag

Bit 5: Received Stop/Repeat-Start Flag

Bit 6: Slave Mode Active Flag

Bit 7: Master Mode Active Flag

ARB:uStatus=0

0 : Normal

1 : Arbitration Lost

GC:uStatus=1

0 : Normal

1 : Currently General Call Operation

A/NA:uStatus=2

0 : No Ack has been transmitted or received.

1 : Ack has been transmitted or received.

DF:uStatus=3

0 : Normal

1 : I2C Data Byte has been transmitted or received.

R/W:uStatus=4

0 : Write Command has been transmitted or received.

1 : Read Command has been transmitted or received.

RX P/Sr: uStatus=5

0 : Normal

1 : Stop/Repeat-Start has been transmitted or received.

SAct:uStatus=6

0 : Inactive

1 : Active

MAct: uStatus=7

0 : Inactive

1 : Active

- **Example**

```
/* Read Flags /  
char flag; flag=DrvI2C_GetStatusFlag ();
```

14.4.16 DrvI2C_TimeOutEnable

- **Prototype**

```
unsigned char DrvI2C_TimeOutEnable(  
E_DRVI2C_TIMEOUT_PRESCALE uPreScale,  
E_DRVI2C_TIMEOUT_LIMIT uTimeOutLimit  
);
```

- **Description**

Enable TimeOut, and set the clock pre scale and time out limit
Configure the register 0X41000[1] , 0X41008[6:0]

- **Parameters**

uPreScale[in]:

- 0 I2C CLK/1
- 1 I2C CLK/2
- 2 I2C CLK/4
- 3 I2C CLK/8
- 4 I2C CLK/16
- 5 I2C CLK/32
- 6 I2C CLK/64
- 7 I2C CLK/128

uTimeOutLimit [in] :

- 0 1 * CLKps Cycle
- 1 2 * CLKps Cycle
- 2 3 * CLKps Cycle
- 3 4 * CLKps Cycle
- 4 5 * CLKps Cycle
- 5 6 * CLKps Cycle
- 6 7 * CLKps Cycle
- 7 8 * CLKps Cycle
- 8 9 * CLKps Cycle
- 9 10 * CLKps Cycle
- 10 11 * CLKps Cycle
- 11 12 * CLKps Cycle
- 12 13 * CLKps Cycle

13 14 * CLKps Cycle

14 15 * CLKps Cycle

15 16 * CLKps Cycle

- **Include**

Peripheral_lib/DrvI2C.h

- **Return Value**

0: Operation successful

0xff: Incorrect argument

- **Example**

```
/*Enable TimeOut , set clock pre scale / 32 and time out limit=15 * CLKps Cycle */
```

```
DrvI2C_TimeOutEnable(5,14);
```

14.4.17 DrvI2C_TimeOutDisable

- **Prototype**

```
void DrvI2C_TimeOutDisable(void)
```

- **Description**

Disable the Timeout

Configure the register 0X41000[1]

- **Parameter**

none

- **Include**

Peripheral_lib/DrvI2C.h

- **Return Value**

None

- **Example**

```
/* Disable time out */
```

```
DrvI2C_TimeOutDisable ();
```

14.4.18 DrvI2C_STSP

- **Prototype**

```
void DrvI2C_STSP(unsigned char usignal);
```

- **Description**

Generate the START or STOP signal from IIC bus.

Configure the register 0X41004[3:2]

- **Parameter**

Usignal[in] signal control

- 0 Generate START singal
- 1 Generate STOP singal

- **Include**

Peripheral_lib/DrvI2C.h

- **Return Value**

None

- **Example**

```
/* Generate the START or STOP singal */  
DrvI2C_ STSP (0);
```

14.4.19 DrvI2C_MGetACK

- **Prototype**

```
unsigned char DrvI2C_MGetACK(unsigned int utime);
```

- **Description**

Check the ACK from slaver during the set time
Configure the register 0X41004[1]

- **Parameter**

utime[in]
the set time :0~0xffff

- **Include**

Peripheral_lib/DrvI2C.h

- **Return Value**

0: ACK was returned
1: No ACK was returned

- **Example**

```
/* check the ACK during the 0xffff time*/  
Err_flag=DrvI2C_ MGetACK (0xffff);
```

14.4.20 DrvI2C_DisableIOPin

- **Prototype**

```
void DrvI2C_DisableIOPin(void)
```

- **Description**

Disable IIC communication function of the IO port
Configure the register 0X40844[16]

- **Parameter**

None

- **Include**

Peripheral_lib/DrvI2C.h

- **Return Value**

None

- **Example**

```
/* Disable IIC communication function of the IO port */  
DrvI2C_DisableIOPin();
```

15.LCD Driver

15.1 Introduction

The following functions are included in LCD Manager Section

Item	Functions	Description
01	DrvLCD_EnableCLK	Set LCD clock source
02	DrvLCD_DisplayMode	Set LCD display mode
03	DrvLCD_VLCDMode	Set VLCD bias voltage
04	DrvLCD_LcdDuty	Set LCD operation period
05	DrvLCD_LCDBuffer	Set LCD buffer
06	DrvLCD_SwpCOMSEG	Reverse the order between COM and SEG
07	DrvLCD_IOMode	Select the operation mode of PT6~PT10 and COM5/COM4
08	DrvLCD_WriteData	Write data to LCD data buffer(LCD0~LCD17)
09	DrvLCD_VLCDTrim	According to factory calibration parameters to calibrate the voltage of VLCD

15.2 The block diagram of LCD

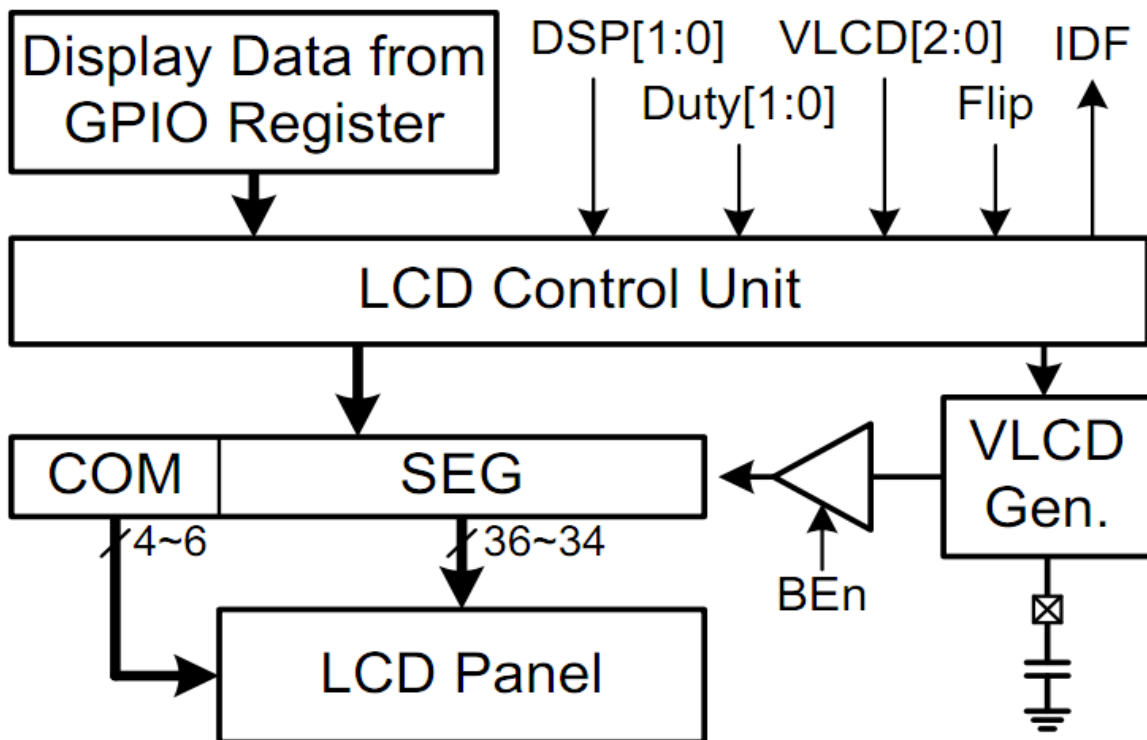

15.3 Type Definition

E_VLCD_MODE

Enumeration Identifier	Value	Description
E_VLCD_DISABLE	0	Disable VLCD
E_VLCD_RTYPE	1	R_TYPE
E_VLCD33	2	VLCD=3.3V
E_VLCD30	3	VLCD=3.0V
E_VLCD27	4	VLCD=2.7V
E_VLCD24	5	VLCD=2.4V

E_LCD_DUTY

Enumeration Identifier	Value	Description
E_LCD_DUTY3	0	LCD operation period:1/3 duty
E_LCD_DUTY4	1	LCD operation period:1/4 duty
E_LCD_DUTY5	2	LCD operation period:1/5 duty
E_LCD_DUTY6	3	LCD operation period:1/6 duty

E_LCD_DISPLAY_MDE

Enumeration Identifier	Value	Description
E_LCD_NORMAL	0	Normal mode
E_LCD_PIXELON	1	The LCD is turned on no matter what the input is
E_LCD_PIXELOFF	2	The LCD is turned off no matter what the input is

15.4 Functions

15.4.1 DrvLCD_EnableCLK

- **Prototype**

unsigned char DrvLCD_EnableCLK(unsigned int uLCD1,unsigned int uLCD2,unsigned int usource)

- **Description**

Set LCD clock source. Select frequency divider of LCDE/LCDO clock source

Configure the register 0X40310[6:0]

- **Parameters**

uLCD2[in] Select frequency divider of LCDE

0: Disable; 1: ÷ 1; 2: ÷ 2; 3: ÷ 4

4: ÷ 8; 5: ÷ 16; 6: ÷ 32; 7: Disable

uLCD1[in] Select frequency divider of LCDO

0: ÷ 1; 1: ÷ 3; 2: ÷ 5; 3: ÷ 7

4: ÷ 9; 5: ÷ 11; 6: ÷ 13; 7: ÷ 15

Usource[in] LCD clock source selection

- 0: LS_CK(alawys/8)
- 1: HS_CK(alawys/64)

- **Include**

Peripheral_lib/DrvLCD.h

- **Return Value**

- 0: Operation successful
- 1 : Incorrect argument

- **Example**

```
/*set HS_CK as LCD clock source, and the frequency divider LCD1*LCD2=5*1; */  
DrvLCD_EnableCLK(2,1,1);
```

15.4.2 DrvLCD_DisplayMode

- **Prototype**

unsigned char DrvLCD_DisplayMode(unsigned int uDISMODE)

- **Description**

Set LCD display mode.

Configure the register 0X41B00[17:16]

- **Parameters**

uDISMODE[in] Set LCD display mode

- 0: normal mode
- 1: The LCD is turned on no matter what the input is
- 2: The LCD is turned off no matter what the input is.

- **Include**

Peripheral_lib/DrvLCD.h

- **Return Value**

- 0: Operation successful
- 1 : Incorrect argument

- **Example**

```
/*set as normal mode */  
DrvLCD_DisplayMode (0);
```

15.4.3 DrvLCD_VLCDMode

- **Prototype**

unsigned char DrvLCD_VLCDMode(unsigned int uVLCDMODE)

- **Description**

Set VLCD bias voltage.

Configure the register 0X41B00[2:0]

- **Parameters**

uVLCDMODE[in] LCD bias voltage selection

0: disable VLCD bias voltage selection

1: R_TYPE mode, Charge PUMP off, VLCD R on

2: 3.3V , Charge PUMP on, VLCD R off

3: 3.0V , Charge PUMP on, VLCD R off

4: 2.7V , Charge PUMP on, VLCD R off

5: 2.4V , Charge PUMP on, VLCD R off

- **Include**

Peripheral_lib/DrvLCD.h

- **Return Value**

0: Operation successful

1 : Incorrect argument

- **Example**

```
/*set 3.0V as LCD bias voltage */
```

```
DrvLCD_VLCDMode (3)
```

15.4. 4 DrvLCD_LcdDuty

- **Prototype**

unsigned char DrvLCD_LcdDuty(unsigned int uDUTY)

- **Description**

Set LCD operation period.

Configure the register 0X41B00[5: 4]

- **Parameters**

uDUTY[in] LCD operation period selection

0: 1/3 Duty 1: 1/4 Duty

2: 1/5 Duty 3: 1/6 Duty

- **Include**

Peripheral_lib/DrvLCD.h

- **Return Value**

0: Operation successful

1 : Incorrect argument

- **Example**

```
/*set as 1/4 Duty */
```

```
DrvLCD_LcdDuty (1);
```

15.4. 5 DrvLCD_LCDBuffer

- **Prototype**

unsigned char DrvLCD_LCDBuffer(unsigned int uBEN)

- **Description**

Set VLCD buffer.

Configure the register 0X41B00[3]

- **Parameters**

uBEN[in] VLCD buffer control

0: disable

1: enable

- **Include**

Peripheral_lib/DrvLCD.h

- **Return Value**

0: Operation successful

1 : Incorrect argument

- **Example**

```
/*enable VLCD buffer */
```

```
DrvLCD_LCDBuffer (1);
```

15.4. 6 DrvLCD_SwpCOMSEG

- **Prototype**

unsigned char DrvLCD_SwpCOMSEG(unsigned int uflip)

- **Description**

Reverse the order between COM and SEG.

Configure the register 0X41B00[6]

- **Parameters**

uflip[in]

0: normal

1: Inversed

- **Include**

Peripheral_lib/DrvLCD.h

- **Return Value**

0: Operation successful

1 : Incorrect argument

- **Example**

```
/*set as normal order */
```

```
DrvLCD_ SwpCOMSEG (0);
```

15.4. 7 DrvLCD_IOMode

- **Prototype**

```
unsigned char DrvLCD_IOMode(unsigned int uport,unsigned int uIOMODE)
```

- **Description**

Select the operation mode of PT6~PT10 and COM5/COM4.

Configure the register 0X41B04/0x41B08

- **Parameters**

uport[in] specified port

0: PT6 1: PT7 2: PT8

3: PT9 4: PT10 5: COM4/COM5

uIOMODE[in] It could be 0~0xff.

The each bit of uIOMODE stand for the mode of corresponding pin

0: I/O mode

1: LCD mode

- **Include**

Peripheral_lib/DrvLCD.h

- **Return Value**

0: Operation successful

1 : Incorrect argument

- **Example**

```
/*set as normal order */
```

```
DrvLCD_ SwpCOMSEG (0);
```

15.4. 8 DrvLCD_WriteData

- **Prototype**

```
unsigned char DrvLCD_WriteData(unsigned int uSEG,unsigned int data)
```

- **Description**

Write data to LCD data buffer(LCD0~LCD17)

Configure the register 0X40850~0x40894

- **Parameters**

uSEG[in] LCD Data Buffer(LCD0~LCD17)

Each buffer has two SEG,such as LCD0=SEG1:SE0;

0~17: corresponding to LCD0~LCD17

Data[in] the data written to LCD buffer, the data is adapted to our SEG position arrangement,it could be 0~0xffff;

Note : the data need to configure your own LCD panel and SEG line arrangement is in agreement with the us

- **Include**

Peripheral_lib/DrvLCD.h

- **Return Value**

0: Operation successful

1 : Incorrect argument

- **Example**

```
/*write 0Xaa to LCD0 */  
DrvLCD_WriteData (0, 0Xaa);
```

15.4. 9 DrvLCD_VLCDTrim

- **Prototype**

unsigned char DrvLCD_VLCDTrim(short Umode)

- **Description**

According to the chip factory calibration parameters of VLCD to calibrate the voltage of VLCD of the chip
Configure the register 0X41B00[2:0]

- **Parameters**

Umode[in] the correction of VLCD voltage mode selection;

1: VLCD~3.43V ; 2: VLCD~3.16V

3: VLCD~2.93V ; 4: VLCD~2.73V

5: VLCD~2.55V

- **Include**

Peripheral_lib/DrvLCD.h

- **Return Value**

0: Operation successful

1 : Incorrect argument

- **Example**

```
/* VLCD calibration voltage :3.16V */  
DrvLCD_VLCDTrim (2);
```

16. FLASH Driver

16.1 Introduction

The following functions are included in FLASH Manager Section.

Item	Functions	Description
01	DrvFlash_Burn_Word	Write a data of word to the specified address
02	ROM_BurnPage	Write 32 data of word to the specified address in a row
03	ReadWord	Read a data of word from the specified address
04	ReadPage	Read 32 data of word from the specified address in a row
05	PageErase	Erase32 data of word to the specified address in a row
06	SectorErase	Erase one sector to the specified address

16.2 Functions

16.2.1 DrvFlash_Burn_Word

- **Prototype**

int DrvFlash_Burn_Word(unsigned int addr,unsigned int DelayTime,unsigned int data);

- **Description**

Write a data of word to the specified address..

- **Parameters**

addr[in] the address to be written

The input range is 0~0xffff, and the start address of flash is0x90000. The interval of address is 4 bytes.

For exemple: The address of 0x9a880 will written a word if addr[in]=0xa880.

Delay time[in] delay time of burning

data [in] the data to be written, it could be 0~0xffffffff

- **Include**

Peripheral_lib/Drvflash.h

- **Return Value**

None

- **Example**

```
/* write the data of 0xFF05 to address of 0x90880 */
```

```
DrvFlash_Burn_Word(0x0880,10,0xff05);
```

16.2.2 ROM_BurnPage

- **Prototype**

int ROM_BurnPage(unsigned int addr,unsigned int DelayTime,int* data);

- **Description**

Write 32 data of word to the specified address in a row one time.

- **Parameters**

addr[in] the initial address to be written

The input range is 0~0xffff, and the start address of flash is0x90000. The interval of address is 128(32*4) bytes, and the page only can be written one by one, for only 128byte in each page . and the address only could be 0xuu00 or 0xuu80. (u is defined by user)

For exemple: The address of 0x9a880 will written a word if addr[in]=0xa880.

Delay time[in] delay time of burning

data [in] the data to be written

it could be 0~0xfffffff . The length of data[in] is 32 word

- **Include**

Peripheral_lib/Drvflash.h

- **Return Value**

None

- **Example**

```
/* write 32 data of word to address of 0x90880 in a row one time */  
int *A[32]={0};  
ROM_BurnPage(0X0880,10, A);
```

16.2.3 ReadWord

- **Prototype**

```
int ReadWord(unsigned int addr);
```

- **Description**

Read a data of word from the specified address .

- **Parameters**

addr[in] the address to be read

The input range is 0~0xffff, and the start address of flash is 0x90000. The interval of address is 4 bytes.

For example: A word will be read from the address of 0x9a880 if addr[in]=0xa880.

- **Include**

Peripheral_lib/Drvflash.h

- **Return Value**

The value of the word

- **Example**

```
/* read the data from the address of 0x90880 */  
Int flag; flag= ReadWord (0x0880 );
```

16.2.4 ReadPage

- **Prototype**

```
int ReadPage(unsigned int addr,int* data);
```

- **Description**

Read 32 data of word from the specified address in a row one time.

- **Parameters**

addr[in] the initial address to be read

The input range is 0~0xffff, and the start address of flash is 0x90000. The interval of address is 128(32*4) bytes, the page only could be read one by one, for only 128byte in each page . and the address only could be

0xuu00 or 0xuu80.

For example: The address of 0x9a880 will be read if `addr[in]=0xa880`.

`data [in]` storage the data to be read

it could be 0~0xfffffff . The length of `data[in]` is 32 word

- **Include**

Peripheral_lib/Drvflash.h

- **Return Value**

None

- **Example**

```
/* read 32 data of word from the address of 0x90880 in a row one time */
```

```
int *A[32]={0};
```

```
ReadPage (0X0880, A);
```

16.2.5 PageErase

- **Prototype**

```
int PageErase(unsigned int addr,unsigned int DelayTime);
```

- **Description**

Erase32 data of word to the specified address in a row one time.

- **Parameters**

`addr[in]` the initial address to Erase

The input range is 0~0xffff, and the start address of flash is 0x90000. The interval of address is 128(32*4) bytes, and the page only can be written one by one, for only 128byte in each page . and the address only could be 0xuu00 or 0xuu80.

For example: The address of 0x9a880 will written a word if `addr[in]=0xa880`.

`Delay time[in]` delay time of burning

- **Include**

Peripheral_lib/Drvflash.h

- **Return Value**

None

- **Example**

```
/* Erase 32 data of word to address of 0x90880 in a row one time */
```

```
PageErase(0x0880,10);
```

16.2.6 SectorErase

- **Prototype**

```
int SectorErase(unsigned int addr,unsigned int DelayTime);
```

- **Description**

Erase one sector to the specified address.

- **Parameters**

addr[in] the initial address to Erase

The input range is 0~0xffff, and the start address of flash is 0x90000. Each sector include 32page. The interval of address is 128*32 bytes, and the first address is calculated by page, the address only could be 0xu000(u is defined by user)

For example: The address of 0x91000 will Erase first if addr[in]=0x1000.

Delay time[in] delay time of burning

- **Include**

Peripheral_lib/Drvflash.h

- **Return Value**

None

- **Example**

```
/* Erase one sector from the initial address of 0x91000 */  
SectorErase(0x1000,10);
```

16.3 The storage structure of Flash

Sector & Page				Block & Sector			
Sector	Page	Address	Range (Byte)	Block	Sector	Address	Range (Byte)
0	0	000000H	00007FH	0	0	000000H	000FFFH
	1	000080H	0000FFH		1	001000H	001FFFH
		2	002000H	002FFFH
	30	000F00H	000F7FH	
	31	000F80H	000FFFH		15	00F000H	00FFFFH
1	32	001000H	00107FH	1	16	010000H	010FFFH
	33	001080H	0010FFH		17	011000H	011FFFH

	63	001F80H	001FFFH		31	01F000H	01FFFFH
...	
15	465	00F000H	00F07FH	15	240	0F0000H	0F0FFFH

	496	00FF80H	00FFFFH		255	0FF000H	0FFFFFH

17. Library

17.1 Library File



Library1.1.zip

HY16F19X Peripheral Driver C Library source code Version 1.1



16F198_LibV1.1.zip

HY16F19X Peripheral Driver C Library Version 1.1

18. Revision History

Version	Page	Revision Summary	The Date Of Revision
V01	ALL	First edition	2014/06/06
V02	ALL	Update the description of TMB2/UART2/flash function Update the description of <i>SYS_INTPriority()</i> Add the description for flash storage struction Delete the description of <i>MassErase()</i>	2014/08/21
V03	ALL	Update the C library: Modify the value of CPPS/CPNS Modify the description of <i>DrvLCD_EnableCLK()</i> Update <i>unsigned int DrvGPIO_LCDIOGetPorts(uint32_t port)</i> Rebuild the C LIB: add the optimization property selection	2014/9/28
V04	ALL	Add new function : <i>DrvGPIO_EnableAnalogPin();</i> Modify the value and description of LCDE/LCDO Add the description of <i>DrvRTC_HourFormat()</i>	2014/11/18
V05	ALL	1. Add new function : <i>DrvCLOCK_CalibrateHAO(short int uMHZ)</i> 2. Modify the performance and description: <i>DrvGPIO_Open()</i> 3. Shielding the underlying interrupt vector set: the ir14 setting 4. Modify the macro definition of DrvADC.H : #define ADINP_MAX 13 #define ADINN_MAX 13 5. <i>DrvGPIO_GetBit ();</i> //the bit0 can be read. 6. <i>DrvLCD_WriteData();</i> //Modify the description and all duty can be used, 7. Update the description of <i>SYS_EnableGIE()</i> 8. Update the description of <i>DrvUART_Enable()</i> 9. Update the description of <i>DrvUART2_Enable()</i> 10. Update the description of <i>DrvSPI32_SETCS()</i> 11. Update the description of <i>DrvCMP_Open()</i> 12. Update the description of <i>DrvCMP_EnableInt, DrvCMP_DisableInt, DrvCMP_ReadIntFlag,</i>	2015/3/26

		<p><i>DrvCMP_ClearIntFlag</i></p> <p>13. Update the description of <i>DrvOP_Pininput()</i></p> <p>14. Update the description of <i>DrvOP_OutputWithCPCLK()</i></p> <p>15. Update the description of <i>DrvSPI32_SetCS0(E_DRV_SPI_CS eCS);</i></p> <p>16. Update the description of</p> <p style="padding-left: 20px;">Page42 : <i>DrvTIMER_EnableInt</i></p> <p style="padding-left: 20px;">Page43 : <i>DrvTIMER_DisableInt</i></p> <p style="padding-left: 20px;">Page43 : <i>DrvTIMER_GetIntFlag</i></p> <p style="padding-left: 20px;">Page44 : <i>DrvTIMER_ClearIntFlag</i></p> <p>17. add small size code function for operation mode setting of PT1/PT2/PT3/PT6/PT7/PT8/PT9/PT10 Begin with <i>DrvGPIO_PT1,DrvGPIO_PT2,DrvGPIO_PT3,DrvGPIO_PT6,DrvGPIO_PT7,DrvGPIO_PT8,DrvGPIO_PT9,DrvGPIO_PT10</i>, for example: <i>void DrvGPIO_PT1_EnableINPUT(short int ubit);</i> <i>void DrvGPIO_PT2_EnableINPUT(short int ubit);</i> <i>void DrvGPIO_PT3_DisableINPUT(short int ubit);</i> <i>void DrvGPIO_PT6_EnableOUTPUT(short int ubit);</i> <i>void DrvGPIO_PT7_ClrPortBits (unsigned int ui32Data);</i> <i>void DrvGPIO_PT8_ClrPortBits (unsigned int ui32Data);</i> <i>void DrvGPIO_PT9_ClrPortBits (unsigned int ui32Data);</i> <i>void DrvGPIO_PT10_EnableINPUT(short int ubit);</i></p>	
V06	ALL	<p>1. Update each IP block diagram, and the Type Definition: ADC(OPO is update as OPOI, REFO is update as REFO_I) OPAMP(OPNS[3] is update as OPOI, OPNS[4] is update as OPO)</p> <p>2. <i>DrvOP_OutputWithCPCLK()</i> is update as <i>DrvOP_OutputWithCHPCK()</i></p> <p>3. <i>DrvRTC_Write()</i> // the HourFormat of 12HR or 24HR can be set correctly , hour value input range for 12HR Format :00~11</p> <p>4. <i>DrvLCD_IOMode()</i>: IO mode can be set correctly</p>	2015/06/16
V07	ALL	<p>1、 Update the c library ;</p> <p>2、 Modify the follow function:</p> <p style="padding-left: 20px;">unsigned int <i>DrvUART_GetPERR(void);</i></p> <p style="padding-left: 20px;">unsigned int <i>DrvUART_GetFERR(void);</i></p> <p style="padding-left: 20px;">unsigned int <i>DrvUART_GetOERR(void);</i></p> <p style="padding-left: 20px;">unsigned int <i>DrvUART_GetNERR(void);</i></p> <p style="padding-left: 20px;">unsigned int <i>DrvUART2_GetPERR(void);</i></p> <p style="padding-left: 20px;">unsigned int <i>DrvUART2_GetFERR(void);</i></p> <p style="padding-left: 20px;">unsigned int <i>DrvUART2_GetOERR(void);</i></p> <p style="padding-left: 20px;">unsigned int <i>DrvUART2_GetNERR(void);</i></p> <p style="padding-left: 20px;">unsigned int <i>DrvGPIO_IntTrigger();</i></p>	2015/09/23
V08	P155/P170	<p>Change input parameter 'uclcok' which data type for 'float' of '<i>DrvUART_Open(); / DrvUART2_Open();</i>'</p> <p>Modify the BaudRate calculation</p> <p>Update the C LIB</p>	2016-01-15
V09	P65/120 P273	<p><i>DrvLCD_WriteData()</i>: modify the programmed algorithm</p> <p>Add new routine '<i>DrvGPIO_PortIDIF()</i>;</p> <p>Update the C LIB</p>	2016-03-04
V10	P273	Update the C LIB	2016-04-20
V11	P273	<p>Update the C LIB:</p> <p><i>DrvLCD_VLCDTrim()</i> could identify the IC body for HY16F198 or HY16F198B automatically.</p>	2016-04-28

19 · C Library Change List

Date	Previous Version List		New version List	
	Version	Bug List	Version	Improvement
2015-2-26	V0.4	<i>DrvGPIO_GetBit()</i> :the value of BIT0 cannot be read correctly	V0.5	Improve the code, each bit can be read correctly
		DrvADC.H : #define ADINP_MAX 9 #define ADINN_MAX 9 The definition lead that the AIO4~AIO7 is unable to set		Modify the macro definition #define ADINP_MAX 13 #define ADINN_MAX 13
		Other interrupt will be disable and that cannot be responsible when enable or disable a interrupt by the Interrupt Vector Enable Setting function		Delete the code of Interrupt Setting Function : disable the interrupt for other module
		<i>DrvGPIO_Open()</i> : The output(input) mode will be disable when the input(output) mode is enable		Delete the code: disable output/input mode
		The lack of HAO frequency correction function		Add new function: <i>DrvCLOCK_CalibrateHAO()</i> ; the HAO frequency can be calibrate by this function
		The original function library compiled code is larger when setting the mode of one IO port		Add new function: Add PT1/PT2/PT3/PT6/PT7/PT8/PT9/PT10 corresponding streamline function
		<i>DrvLCD_WriteData()</i> : Only use 1/4duty		all duty can be used
				Add new function: <i>DrvSPI32_SetCSO</i> (<i>E_DRVSPi_CS eCS</i>)

Date	Previous Version List		New version List	
	Version	Bug List	Version	Improvement
2015-06-16	V0.5	<i>DrvRTC_Write()</i> : the hour formate is set incorrectly	V0.6	the HourFormat of 12HR or 24HR can be set correctly , hour value input range for 12HR Format :00~11
		<i>DrvLCD_IOMode()</i> : IO mode cannot be set		IO or LCD mode can be set correctly
		When a bit value of register 0x41808 is change the other bit value may be covered with 0x41804		<i>DrvCMP_RLO_refV</i> (); <i>DrvCMP_EnableNonOverlap</i> (); <i>DrvCMP_DisableNonOverlap</i> (); Only the corresponding bit value of register 0x41808 is modify
		Update the block diagram of each IP		Update the Type Definition: ADC(OPO is update as OPOI, ACM is update as REFO_I) OPAMP(OPNS[3] is update as OPOI, OPNS[4] is update as OPO)
		Add new function: <i>DrvOP_OutputWithCHPCK</i> (<i>uCHPCK</i>)		

Date	Previous Version List		New version List	
	Version	Bug List	Version	Improvement
2015-09-23	V0.6	DrvGPIO_IntTrigger();: Enable the external interrupt of IOPORT when setting trige edge;	V0.7	Delect the program of enablet the IO port external interrupt;
		<i>There is wrong in bit operation with the follow function:</i> unsigned int DrvUART_GetPERR(void); unsigned int DrvUART_GetFERR(void); unsigned int DrvUART_GetOERR(void); unsigned int DrvUART_GetNERR(void); unsigned int DrvUART2_GetPERR(void); unsigned int DrvUART2_GetFERR(void); unsigned int DrvUART2_GetOERR(void); unsigned int DrvUART2_GetNERR(void);		Modify the algorithm of bit operation For all function;

Date	Previous Version List		New version List	
	Version	Bug List	Version	Improvement
2016-1-15	V0.7	<i>DrvUART_Open():</i> <i>/DrvUART_Open():</i> <i>The input parameter clock source number can not be the decimals</i>	V0.8	Change the input parameter –‘uclock’ for ‘float ‘ data type;
		There is wrong calculation with ‘Baud Rate’ in the C lib;		modify the algorithm of Baud Rate calculation
		The ‘printf()’ output by the UART only		Change to output by ‘UART/UART2’

Date	Previous Version List		New version List	
	Version	Bug List	Version	Improvement
2016-03-04	V0.8	<i>DrvLCD_WriteData():</i> <i>It change the PT6~10 output status when any PIN be set as GPIO MODE,not LCD MODE.</i>	V0.9	Modify the programmed algorithm , when any PIN be set as GPIO mode couldn’t operation the corresponding register;
		Have no routine to read PT1/PT2 interrupt trigger condition flag.		Add new routine to operate.

Date	Previous Version List		New version List	
	Version	Bug List	Version	Improvement
2016-04-20	V0.9	<i>DrvUART_Open():</i> <i>/DrvUART_Open():</i> There is wrong calculation with 'Baud Rate' in the C lib;	V1.0	modify the algorithm of Baud Rate calculation
		<i>DrvLCD_VLCDTrim() need to update operation register</i>		Update the operation register

Date	Previous Version List		New version List	
	Version	Bug List	Version	Improvement
2016-04-28	V1.0	<i>DrvLCD_VLCDTrim() can't deffer the HY16F198 or HY16F198B automatically</i>	V1.1	Update the algorithm,which could identify the HY16F198 or HY16F198B automatically