



HY2113

Data Sheet

1-Cell Lithium-ion/Lithium Polymer
Battery Packs Protection ICs

Table of Contents

1. GENERAL DESCRIPTION	4
2. FEATURES	4
3. APPLICATIONS	4
4. BLOCK DIAGRAM	5
5. ORDERING INFORMATION	5
6. MODEL LIST	6
6.1. Product Name List	6
6.2. Delay Time Code-Parameter Option of Delay Time	7
6.3. Characteristic Code-Other function Option	8
7. PIN CONFIGURATION AND PACKAGE MARKING INFORMATION	8
8. ABSOLUTE MAXIMUM RATINGS	9
9. ELECTRICAL CHARACTERISTICS	10
9.1. Electrical Characteristics (Except Delay Time Parameter)	10
9.2. Delay Time Combination	11
10. EXAMPLE OF BATTERY PROTECTION IC CONNECTION	12
11. DESCRIPTION OF OPERATION	13
11.1. Normal Status	13
11.2. Overcharge Status	13
11.3. Overdischarge Status	14
11.4. Discharge Overcurrent Status (Discharge Overcurrent & Short Circuit)	14
11.5. Charge Overcurrent Status	15
11.6. 0V Battery Charging Function “Available”	15
11.7. 0V Battery Charging Function “Unavailable”	16
12. CHARACTERISTICS (TYPICAL VALUE)	17
13. PACKAGE INFORMATION	20
13.1. DFN-6L Outline	20
13.2. SOT-23-6 Outline	21
14. REVISION RECORD	22

Attention :

1. HYCON Technology Corp. reserves the right to change the content of this datasheet without further notice. For most up-to-date information, please constantly visit our website:
<http://www.hycontek.com> .
2. HYCON Technology Corp. is not responsible for problems caused by figures or application circuits narrated herein whose related industrial properties belong to third parties.
3. Specifications of any HYCON Technology Corp. products detailed or contained herein stipulate the performance, characteristics, and functions of the specified products in the independent state. We does not guarantee of the performance, characteristics, and functions of the specified products as placed in the customer's products or equipment. Constant and sufficient verification and evaluation is highly advised.
4. Please note the operating conditions of input voltage, output voltage and load current and ensure the IC internal power consumption does not exceed that of package tolerance. HYCON Technology Corp. assumes no responsibility for equipment failures that resulted from using products at values that exceed, even momentarily, rated values listed in products specifications of HYCON products specified herein.
5. Notwithstanding this product has built-in ESD protection circuit, please do not exert excessive static electricity to protection circuit.
6. Products specified or contained herein cannot be employed in applications which require extremely high levels of reliability, such as device or equipment affecting the human body, health/medical equipments, security systems, or any apparatus installed in aircrafts and other vehicles.
7. Despite the fact that HYCON Technology Corp. endeavors to enhance product quality as well as reliability in every possible way, failure or malfunction of semiconductor products may happen. Hence, users are strongly recommended to comply with safety design including redundancy and fire-precaution equipments to prevent any accidents and fires that may follow.
8. Use of the information described herein for other purposes and/or reproduction or copying without the permission of HYCON Technology Corp. is strictly prohibited.

1. General Description

The series of **HY2113** ICs is best created for single-cell lithium-ion/lithium polymer rechargeable battery protection and it also comprises high-accuracy voltage detectors and delay circuits.

These ICs are suitable for protecting single-cell rechargeable lithium-ion/lithium polymer battery packs against the problems of overcharge, overdischarge and overcurrent.

2. Features

The features that whole series of HY2113 comprised are as follows:

(1) High-accuracy voltage detection circuit

- Overcharge detection voltage 4.000 to 4.500V Accuracy: $\pm 25\text{mV}$
- Overcharge release voltage 3.800 to 4.500V Accuracy: $\pm 50\text{mV}$
- Overdischarge detection voltage 2.00 to 3.10V Accuracy: $\pm 50\text{mV}$
- Overdischarge release voltage 2.00 to 3.40V Accuracy: $\pm 50\text{mV}$
- Discharge overcurrent detection voltage 25 to 250mV Accuracy: $\pm 15\text{mV}$
- Charge overcurrent detection voltage -40mV to -100mV Accuracy: $\pm 20\text{mV}$
- Short-circuiting detection voltage 0.85V(fixed) Accuracy: $\pm 0.3\text{V}$

(2) Delay times are generated by an internal circuit (external capacitors are unnecessary).

(3) Power-down function “Yes” / “No” are selectable (See Model List).

(4) Auto overdischarge recovery function “Yes” / “No” are selectable (See Model List).

(5) Low current consumption (Products with Power-down Function)

- Operation mode 3.0 μA typ., 6.0 μA max. (VDD=3.9V)
- Ultra low power-down current at 0.1 μA max. (VDD=2.0V)

(6) High-withstanding-voltage device is used for charger connection pins

(CS pin and OC pin: Absolute maximum rating = 20 V)

(7) 0 V battery charge function “available” / “unavailable” are selectable (See Model List).

(8) Wide operation temperature range -40°C to +85 °C

(9) Small package DFN-6L & SOT-23-6

(10) The HY2113 series are Halogen-free, green package

3. Applications

- 1-cell lithium-ion rechargeable battery packs
- 1-cell lithium polymer rechargeable battery packs

4. Block Diagram

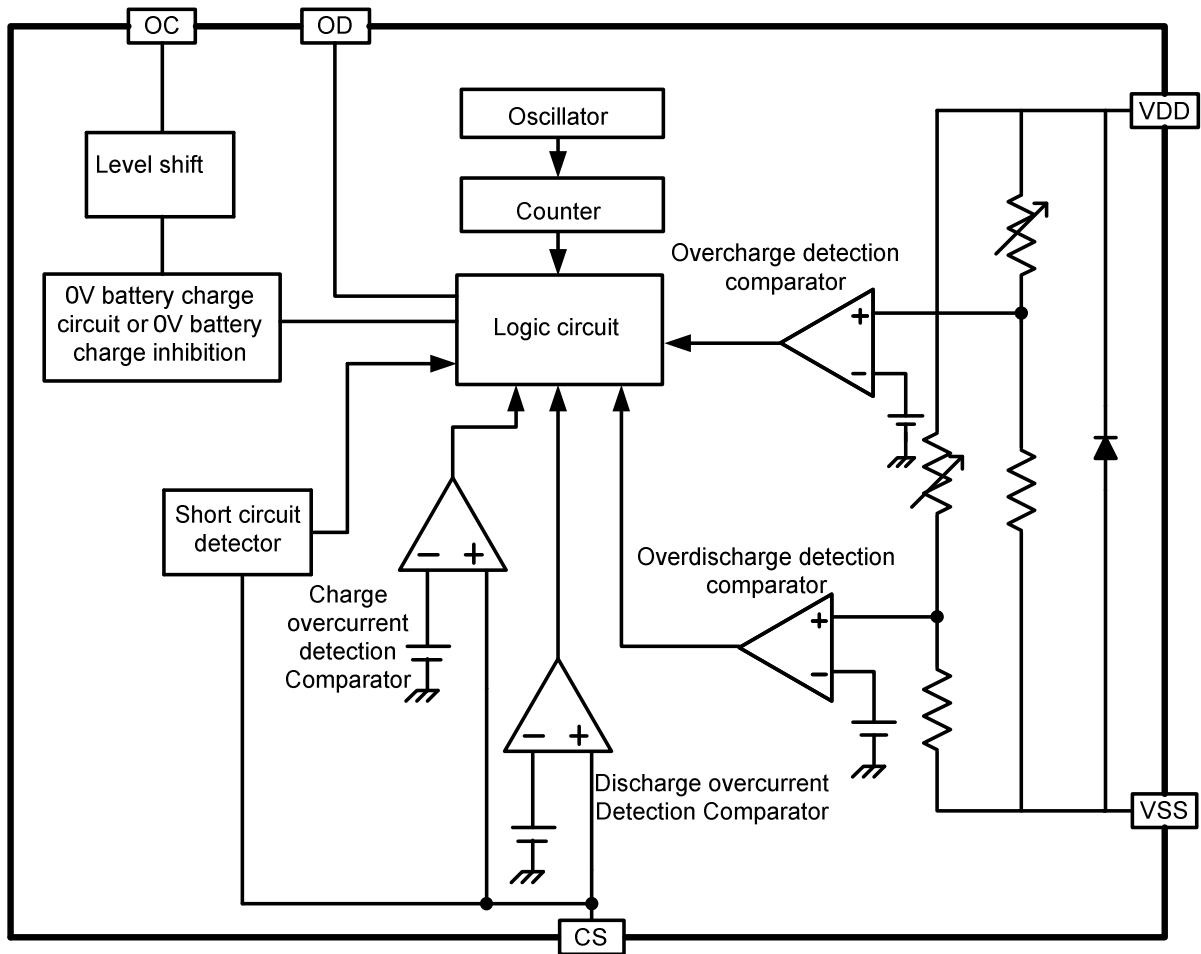

5. Ordering Information

■ Product name definition

HY2113—#%\$&

- Characteristic code
Alphabetically set from A to Z
- Delay time code
Sequentially set from 1 to 9
- Package type
A: DFN-6L
B: SOT-23-6
- Serial code
Alphabetically set from A to Z

6. Model List

6.1. Product Name List

For DFN-6L

Table 1 Model list for DFN-6L

Model	Over-charge detection voltage	Over-charge release voltage	Over-discharge detection voltage	Over-discharge release voltage	Discharge overcurrent detection voltage	Charge overcurrent detection voltage	Delay Time Code	Characteristic Code
	V _{CU}	V _{CR}	V _{DL}	V _{DR}	V _{DIP}	V _{CIP}		
HY2113-AA1A	4.280V	4.080V	2.30V	2.30V	125mV	-100mV	1	A
HY2113-BA1A	4.325V	4.125V	2.50V	2.80V	150mV	-100mV	1	A
HY2113-CA1A	4.275V	4.075V	2.30V	2.30V	150mV	-100mV	1	A
HY2113-DA1A	4.275V	4.175V	2.30V	2.40V	100mV	-100mV	1	A
HY2113-EA1B	4.300V	4.100V	2.30V	2.30V	150mV	-100mV	1	B
HY2113-FA2B	4.250V	4.050V	2.50V	2.80V	200mV	-100mV	2	B
HY2113-GA3A	4.280V	4.080V	3.00V	3.00V	75mV	-50mV	3	A
HY2113-HA3A	4.280V	4.280V	2.80V	2.80V	50mV	-50mV	3	A
HY2113-IA2C	4.190V	4.190V	2.70V	3.00V	100mV	-40mV	2	C
HY2113-LA1A	4.200V	4.200V	2.50V	2.50V	150mV	-100mV	1	A
HY2113-MA1A	4.280V	4.280V	2.80V	2.80V	250mV	-100mV	1	A
HY2113-NA4A	4.380V	4.280V	2.60V	2.80V	150mV	-100mV	4	A
HY2113-NA4B	4.380V	4.280V	2.60V	2.80V	150mV	-100mV	4	B
HY2113-OA1B	4.400V	4.200V	2.80V	3.00V	150mV	-100mV	1	B
HY2113-JA1B	4.275V	4.075V	3.00V	3.20V	150mV	-100mV	1	B

Remark:

1. Table 1 lists out typical value of every electrical parameter. Please refer to Table 8 for detailed electrical characteristics.
2. Table 3 lists out delay time parameters of every corresponding delay time code. Table 4 lists out characteristic function of every corresponding characteristic code.
3. Please contact our sales office for the products with detection voltage value other than those specified above.

For SOT-23-6

Table 2 Model list for SOT-23-6

Model	Over-charge detection voltage	Over-charge release voltage	Over-discharge detection voltage	Over-discharge release voltage	Discharge overcurrent detection voltage	Charge overcurrent detection voltage	Delay Time Code	Characteristic Code
	V _{CU}	V _{CR}	V _{DL}	V _{DR}	V _{DIP}	V _{CIP}		
HY2113-AB1A	4.280V	4.080V	2.30V	2.30V	125mV	-100mV	1	A
HY2113-BB1A	4.325V	4.125V	2.50V	2.80V	150mV	-100mV	1	A
HY2113-CB1A	4.275V	4.075V	2.30V	2.30V	150mV	-100mV	1	A
HY2113-DB1A	4.275V	4.175V	2.30V	2.40V	100mV	-100mV	1	A
HY2113-EB1B	4.300V	4.100V	2.30V	2.30V	150mV	-100mV	1	B
HY2113-FB2B	4.250V	4.050V	2.50V	2.80V	200mV	-100mV	2	B
HY2113-GB3A	4.280V	4.080V	3.00V	3.00V	75mV	-50mV	3	A
HY2113-HB3A	4.280V	4.280V	2.80V	2.80V	50mV	-50mV	3	A
HY2113-IB2C	4.190V	4.190V	2.70V	3.00V	100mV	-40mV	2	C
HY2113-LB1A	4.200V	4.200V	2.50V	2.50V	150mV	-100mV	1	A
HY2113-MB1A	4.280V	4.280V	2.80V	2.80V	250mV	-100mV	1	A
HY2113-NB4A	4.380V	4.280V	2.60V	2.80V	150mV	-100mV	4	A
HY2113-NB4B	4.380V	4.280V	2.60V	2.80V	150mV	-100mV	4	B
HY2113-OB1B	4.400V	4.200V	2.80V	3.00V	150mV	-100mV	1	B
HY2113-JB1B	4.275V	4.075V	3.00V	3.20V	150mV	-100mV	1	B

Remark:

1. Table 2 lists out typical value of every electrical parameter. Please refer to Table 8 for detailed electrical characteristics.
2. Table 3 lists out delay time parameters of every corresponding delay time code. Table 4 lists out characteristic function of every corresponding characteristic code.
3. Please contact our sales office for the products with detection voltage value other than those specified above.

6.2. Delay Time Code-Parameter Option of Delay Time

Table 3 Delay Time Code- Delay Time Parameter Option

Delay Time Code	Overcharge Delay Time	Overdischarge Delay Time	Discharge Overcurrent Delay Time	Charge Overcurrent Delay Time	Short Circuit Delay Time
	T _{OC}	T _{OD}	T _{DIP}	T _{CIP}	T _{SIP}
1	1200ms	140ms	12ms	8ms	300μs
2	1000ms	20ms	12ms	8ms	300μs
3	1200ms	140ms	6ms	8ms	300μs
4	250ms	20ms	12ms	8ms	150μs

Remark:

1. Table 3 lists out typical value of every delay time parameters, for detailed delay time combination please refer to Table 9 to Table 12.

6.3. Characteristic Code-Other function Option

Table 4 Characteristic Code-Other function Option

Characteristic Code	0 V Battery Charge Function	Power-down Function/ Auto Overdischarge Recovery Function
A	Available	With power-down Function
B	Available	With auto overdischarge recovery function
C	Unavailable	With auto overdischarge recovery function

7. Pin Configuration and Package Marking Information

- For DFN-6L

Table 5 DFN-6L

Pin No.	Symbol	Description
1	NC	No connection.
2	OC	MOSFET gate connection pin for charge control
3	OD	MOSFET gate connection pin for discharge control
4	VSS	Ground pin
5	VDD	Power supply pin
6	CS	Input pin for current sense, charger detect pin

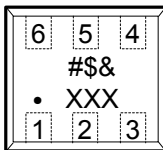

#: Serial code. Alphabetically set from A to Z.

\$: Delay time code. Sequentially set from 1 to 9.

&: Characteristic code. Alphabetically set from A to Z.

xxx: Date code.

- For SOT-23-6

Table 6 SOT-23-6

Pin No.	Symbol	Description
1	OD	MOSFET gate connection pin for discharge control
2	CS	Input pin for current sense, charger detect pin
3	OC	MOSFET gate connection pin for charge control
4	NC	No connection.
5	VDD	Power supply pin
6	VSS	Ground pin

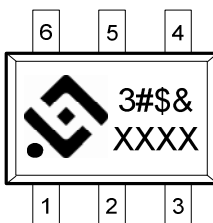

3: Product Name.

#: Serial code. Alphabetically set from A to Z.

\$: Delay time code. Sequentially set from 1 to 9.

&: Characteristic code. Alphabetically set from A to Z.

XXXX: Date code.

8. Absolute Maximum Ratings

Table 7 Absolute Maximum Ratings (VSS=0V, Ta=25°C unless otherwise specified)

Item	Symbol	Rating	Unit
Input voltage between VDD and VSS pin	V _{DD}	VSS-0.3 to VSS+10	V
OC output pin voltage	V _{OC}	VDD-20 to VDD+0.3	V
OD output pin voltage	V _{OD}	VSS-0.3 to VDD+0.3	V
CS input pin voltage	V _{CS}	VDD-20 to VDD+0.3	V
Operating Temperature Range	T _{OP}	-40 to +85	°C
Storage Temperature Range	T _{ST}	-40 to +125	°C
Power dissipation	P _D	250	mW

9. Electrical Characteristics

9.1. Electrical Characteristics (Except Delay Time Parameter)

Table 8 Electrical Characteristics (VSS=0V, Ta=25°C unless otherwise specified)

Item	Symbol	Condition	Min.	Typ.	Max.	Unit	
SUPPLY POWER RANGE							
Operating voltage between VDD pin and VSS pin	V_{DSOP1}	-	1.5	-	8	V	
Operating voltage between VDD pin and CS pin	V_{DSOP2}	-	1.5	-	20	V	
INPUT CURRENT(with Power-down Function)							
Supply Current	I_{DD}	$V_{DD}=3.9V$	-	3.0	6.0	μA	
Power-Down Current	I_{PD}	$V_{DD}=2.0V$	-	-	0.1	μA	
INPUT CURRENT(with Auto Overdischarge Recovery Function)							
Supply Current	I_{DD}	$V_{DD}=3.9V$	-	3.0	6.0	μA	
Overdischarge Current Consumption	I_{OD}	$V_{DD}=2.0V$	-	0.16	0.5	μA	
DETECTION VOLTAGE							
Overcharge Detection Voltage	V_{CU}	4.0V to 4.5V adjustable	V_{CU} -0.025	V_{CU}	V_{CU} +0.025	V	
		4.0V to 4.5V adjustable -5°C to +55°C (Note)	V_{CU} -0.035	V_{CU}	V_{CU} +0.035	V	
Overcharge Release Voltage	V_{CR}	3.8V to 4.5V adjustable	$V_{CR} \neq V_{CU}$	$V_{CR}-0.05$	V_{CR}	$V_{CR}+0.05$	V
			$V_{CR} = V_{CU}$	$V_{CR}-0.05$	V_{CR}	$V_{CR}+0.025$	V
Overdischarge Detection Voltage	V_{DL}	2.0V to 3.1V adjustable	$V_{DL}-0.05$	V_{DL}	$V_{DL}+0.05$	V	
Overdischarge Release Voltage	V_{DR}	2.0V to 3.4V adjustable	$V_{DR}-0.05$	V_{DR}	$V_{DR}+0.05$	V	
Discharge Overcurrent Detection Voltage	V_{DIP}	$V_{DD}=3.6V$	$V_{DIP}-15$	V_{DIP}	$V_{DIP}+15$	mV	
Short Circuit Detection Voltage	V_{SIP}	$V_{DD}=3.0V$	0.55	0.85	1.15	V	
Charge overcurrent detection voltage	V_{CIP}	$V_{DD}=3.6V$	$V_{CIP}-20$	V_{CIP}	$V_{CIP}+20$	mV	
CONTROL OUTPUT VOLTAGE(OD&OC)							
OD Pin Output "H" Voltage	V_{DH}		$V_{DD}-0.1$	$V_{DD}-0.02$	-	V	
OD Pin Output "L" Voltage	V_{DL}		-	0.1	0.5	V	
OC Pin Output "H" Voltage	V_{CH}		$V_{DD}-0.1$	$V_{DD}-0.02$	-	V	
OC Pin Output "L" Voltage	V_{CL}		-	0.1	0.5	V	
0V BATTERY CHARGE FUNCTION							
0V battery charge starting charger voltage	V_{0CH}	0V battery charging function "available"	1.2	-	-	V	
0V battery charge inhibition charger voltage	V_{0IN}	0V battery charging function "unavailable"	-	-	0.5	V	

Note: Since products are not screened at high and low temperature, the specification for this temperature range is guaranteed by design, not tested in production.

9.2. Delay Time Combination

Table 9 Delay Time Parameter Combination of Delay Time Code: 1

Item	Symbol	Condition	Min.	Typ.	Max.	Unit
Overcharge Delay Time	T_{OC}	$V_{DD}=3.9V \rightarrow 4.5V$	900	1200	1500	ms
Overdischarge Delay Time	T_{OD}	$V_{DD}=3.6V \rightarrow 2.0V$	105	140	175	ms
Discharge Overcurrent Delay Time	T_{DIP}	$V_{DD}=3.6V, CS=0.4V$	9	12	15	ms
Charge Overcurrent Delay Time	T_{CIP}	$V_{DD}=3.6V, CS=-0.2V$	6	8	10	ms
Short Circuit Delay Time	T_{SIP}	$V_{DD}=3.0V, CS=1.3V$	200	300	400	μs

Table 10 Delay Time Parameter Combination of Delay Time Code: 2

Item	Symbol	Condition	Min.	Typ.	Max.	Unit
Overcharge Delay Time	T_{OC}	$V_{DD}=3.9V \rightarrow 4.5V$	700	1000	1300	ms
Overdischarge Delay Time	T_{OD}	$V_{DD}=3.6V \rightarrow 2.0V$	15	20	25	ms
Discharge Overcurrent Delay Time	T_{DIP}	$V_{DD}=3.6V, CS=0.4V$	9	12	15	ms
Charge Overcurrent Delay Time	T_{CIP}	$V_{DD}=3.6V, CS=-0.2V$	6	8	10	ms
Short Circuit Delay Time	T_{SIP}	$V_{DD}=3.0V, CS=1.3V$	200	300	400	μs

Table 11 Delay Time Parameter Combination of Delay Time Code: 3

Item	Symbol	Condition	Min.	Typ.	Max.	Unit
Overcharge Delay Time	T_{OC}	$V_{DD}=3.9V \rightarrow 4.5V$	900	1200	1500	ms
Overdischarge Delay Time	T_{OD}	$V_{DD}=3.6V \rightarrow 2.0V$	105	140	175	ms
Discharge Overcurrent Delay Time	T_{DIP}	$V_{DD}=3.6V, CS=0.4V$	4	6	8	ms
Charge Overcurrent Delay Time	T_{CIP}	$V_{DD}=3.6V, CS=-0.2V$	6	8	10	ms
Short Circuit Delay Time	T_{SIP}	$V_{DD}=3.0V, CS=1.3V$	200	300	400	μs

Table 12 Delay Time Parameter Combination of Delay Time Code: 4

Item	Symbol	Condition	Min.	Typ.	Max.	Unit
Overcharge Delay Time	T_{OC}	$V_{DD}=3.9V \rightarrow 4.5V$	200	250	300	ms
Overdischarge Delay Time	T_{OD}	$V_{DD}=3.6V \rightarrow 2.0V$	15	20	25	ms
Discharge Overcurrent Delay Time	T_{DIP}	$V_{DD}=3.6V, CS=0.4V$	9	12	15	ms
Charge Overcurrent Delay Time	T_{CIP}	$V_{DD}=3.6V, CS=-0.2V$	6	8	10	ms
Short Circuit Delay Time	T_{SIP}	$V_{DD}=3.0V, CS=1.3V$	100	150	200	μs

10. Example of Battery Protection IC Connection

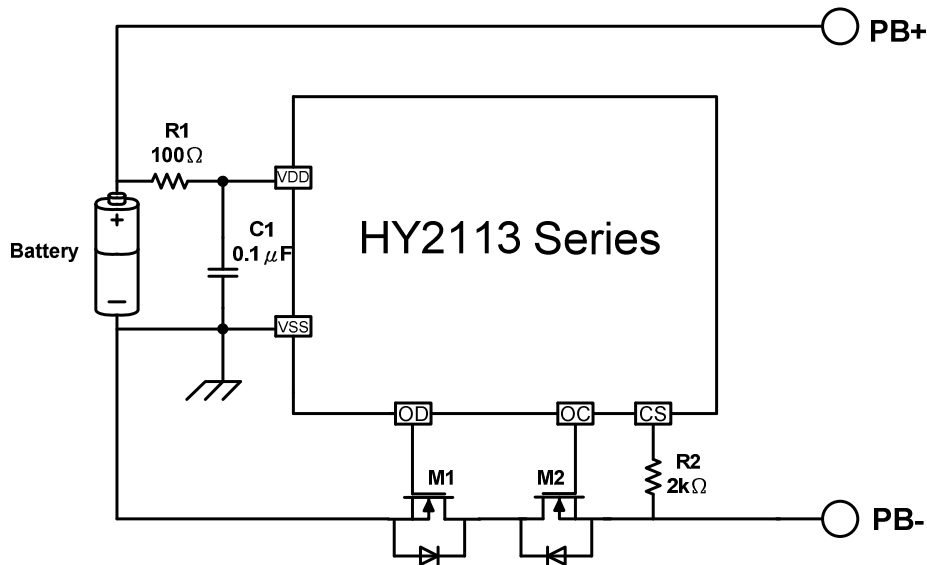

Symbol	Device Name	Purpose	Min.	Typ.	Max.	Remark
R1	Resistor	limit current, stabilize VDD and strengthen ESD protection	100Ω	100Ω	200Ω	*1
R2	Resistor	limit current	1kΩ	2kΩ	2kΩ	*2
C1	Capacitor	stabilize VDD	0.01μF	0.1μF	1.0μF	*3
M1	N-MOSFET	Discharge control	-	-	-	*4
M2	N-MOSFET	Charge control	-	-	-	*5

- *1. R1 should be as small as possible to avoid lowering the overcharge detection accuracy due to current consumption. When a charger is connected in reversed, the current flows from the charger to the IC. At this time, if R1 is connected to high resistance, the voltage between VDD pin and VSS pin may exceed the absolute maximum rating.
- *2. If R2 has a resistance higher than 2kΩ, the charging current may not be cut when a high-voltage charger is connected. Please select as large a resistance as possible to prevent current when a charger is connected in reversed.
- *3. C1 will stabilize the supply voltage of VDD, the value of C1 should be equal to or more than 0.01μF.
- *4. If a FET with a threshold voltage equal to or higher than the overdischarge detection voltage is applied, discharging may be stopped before overdischarge is detected.
- *5. If the withstanding voltage between the gate and source is lower than the charger voltage, the FET may be destroyed.

Caution :

1. The above constants may be changed without notice , please download the most up-to-date datasheet on our website. <http://www.hycontek.com>
2. It is advised to perform thorough evaluation and test if peripheral devices need to be adjusted.

11. Description of Operation

11.1. Normal Status

This IC monitors the voltage of the battery connected between the VDD pin and VSS pin and the voltage difference between the CS pin and VSS pin to control charging and discharging.

When the battery voltage is in the range from overdischarge detection voltage (V_{DL}) to overcharge detection voltage (V_{CU}), and the CS pin voltage is in the range from the charge overcurrent detection voltage (V_{CIP}) to discharge overcurrent detection voltage (V_{DIP}), the IC turns both the charging and discharging control MOSFET on. This condition is called the normal status. Under this condition, charging and discharging can both be carried out freely.

Notice:

Discharging may not be enacted when the battery is first time connected. To regain normal status, CS pin and VSS pin must be shorted or the charger must be connected.

11.2. Overcharge Status

Under the normal status, as soon as the battery voltage becomes higher than the overcharge detection voltage (V_{CU}) during charging and the detection continues longer than the overcharge detection delay time (T_{OC}), the HY2113 series will turn the charging control MOSFET off (OC pin) to stop charging. This condition is called the overcharge status.

The overcharge status can be released by the following two cases:

Condition: disconnect charger

(1) The voltage of the battery cell is equal to or lower than the overcharge release voltage (V_{CR}) due to self-discharge.

(2) When the load is connected, the discharge current will pass through parasitical diode of charging control MOSFET. At this time, CS pin will detect "Diode forward voltage drop (V_f)". When CS pin voltage rises higher than discharge overcurrent detection voltage (V_{DIP}) and battery voltage lowers than overcharge detection voltage (V_{CU}), the overcharge status will be released and back to normal status.

Caution:

When a charger is connected after overcharge detection, the overcharge status is not released even if the battery voltage is below overcharge release voltage (V_{CR}). The overcharge status is released when the CS pin voltage goes over the charge overcurrent detection voltage (V_{CIP}) by removing the charger.

11.3. Overdischarge Status

11.3.1. Products with Power-down Function

When the battery voltage falls below than the overdischarge detection voltage (V_{DL}) during discharging in the normal status and the detection continues longer than the overdischarge detection delay time (T_{OD}), the HY2113 series will turn the discharging control MOSFET off(OD pin) so as to stop discharging. This condition is called the overdischarge status.

When the MOSFET is off, CS pin voltage is pulled up by the resistor to VDD in the IC, at this time, the power consumption is reduced to the lowest. This condition is called the "SLEEP MODE".

The overdischarge status will be released by two cases:

- (1) When CS pin voltage is equal to or lower than the charge overcurrent detection voltage (V_{CIP}) by charging and the VDD pin voltage is higher than the overdischarge detection voltage (V_{DL}).
- (2) When CS pin voltage is equal to or higher than the charge overcurrent detection voltage (V_{CIP}) by charging and the VDD pin voltage is higher than the overdischarge release voltage (V_{DR}).

11.3.2. Products with Auto Overdischarge Recovery Function

When the battery voltage falls below than the overdischarge detection voltage (V_{DL}) during discharging in the normal status and the detection continues longer than the overdischarge detection delay time (T_{OD}), the HY2113 series will turn the discharging control MOSFET off(OD pin) so as to stop discharging. This condition is called the overdischarge status.

The overdischarge status will be released by three cases:

- (1) When CS pin voltage is equal to or lower than the charge overcurrent detection voltage (V_{CIP}) by charging and the VDD pin voltage is higher than the overdischarge detection voltage (V_{DL}).
- (2) When CS pin voltage is equal to or higher than the charge overcurrent detection voltage (V_{CIP}) by charging and the VDD pin voltage is higher than the overdischarge release voltage (V_{DR}).
- (3) Without connecting a charger, if the VDD pin voltage is higher than overdischarge release voltage (V_{DR}), the overdischarge status will be released, namely Auto Overdischarge Recovery Function.

11.4. Discharge Overcurrent Status (Discharge Overcurrent & Short Circuit)

Under normal condition, the HY2113 continuously monitors the discharge current by sensing the voltage of CS pin. If the voltage of CS pin exceeds the overcurrent detection voltage (V_{DIP}) and the condition lasts beyond the overcurrent delay time (T_{DIP}),

discharging will be suspended by turning off the discharge control MOSFET (OD pin). This condition is called the discharge overcurrent status.

If the voltage of CS pin exceeds the short circuit detection voltage (V_{SIP}) and the condition lasts beyond the short circuit delay time (T_{SIP}), discharging will be suspended by turning off the discharge control MOSFET (OD pin). This condition is called the short circuit status.

When the impedance between PB+ and PB- is higher than discharge overcurrent and short circuit release impedance (300k Ω typ.), the discharge overcurrent status and short circuit status will be released and back to normal operation status. In addition, if the impedance between PB+ and PB- is less than discharge overcurrent and short circuit release impedance, CS pin voltage will descend below than overcurrent detection voltage (V_{DIP}) after the charger is being connected, discharge overcurrent status and short circuit status will be released and back to normal operation status.

Caution:

(1) If the charger is connected incautiously in reversed, the current direction is the same as discharge current in the circuit. If CS pin voltage goes higher than overcurrent detection voltage (V_{DIP}), it will enter into discharge overcurrent protection status to block out in-circuit current.

11.5. Charge Overcurrent Status

When a battery is in the normal status, the voltage of the CS pin is lower than the charge overcurrent detection voltage (V_{CIP}). When the charge current is higher than the specified value and the status lasts beyond the charge overcurrent detection delay time (T_{CIP}), the charge control MOSFET will be turned off and charging is stopped. This status is called the charge overcurrent status.

This IC will be restored to the normal status from the charge overcurrent status when the voltage at the CS pin returns to charge overcurrent detection voltage (V_{CIP}) or higher by removing the charger.

11.6. 0V Battery Charging Function “Available”

This function is used to recharge a connected battery which voltage is 0V due to self-discharge. When the 0V battery charge starting charger voltage (V_{0CH}) or a higher voltage is applied between the battery+ (PB+) and battery- (PB-) pins by connecting a charger, the charging control MOSFET gate is fixed to the VDD pin voltage.

When the voltage between the gate and the source of the charging control MOSFET becomes equal to or higher than the turn on voltage due to the charger voltage, the charging control MOSFET is turned on to initiate charging. At this time, the discharging control MOSFET is off and the charging current flows through the internal parasitic diode in the discharging control MOSFET. When the battery voltage becomes equal to or higher

than overdischarge detection voltage (V_{DL}), the HY2113 series will enter into the normal status.

Caution

(1) Some battery providers do not recommend charging for a completely self-discharged battery. Please ask the battery provider to determine whether to enable or prohibit the 0V battery charging function.

(2) The 0V battery charge function has higher priority than the charge overcurrent detection function. Consequently, a product in which use of the 0V battery charging function is enabled to forcibly charge a battery and the charge current cannot be detected when the battery voltage is lower than overdischarge detection voltage (V_{DL}).

11.7. 0V Battery Charging Function “Unavailable”

When a battery that is internally short-circuited (0V battery) is connected, the unavailable 0V charging function will prohibit recharging. When the battery voltage equals to the 0V battery charge inhibition battery voltage (V_{OIN}) or lower, the charging control MOSFET gate is fixed to the PB- pin voltage to prohibit charging. When the battery voltage equals to the 0V battery charge inhibition battery voltage (V_{OIN}) or higher, charging can be implemented.

Caution

(1) Some battery providers do not recommend charging for a completely self-discharged battery. Please ask the battery provider to determine whether to enable or prohibit the 0V battery charging function.

12. Characteristics (Typical Value)

1. Overcharge Detection/Release Voltage, Overdischarge Detection/Release Voltage, Discharge Overcurrent Detection Voltage, Short Circuit Detection Voltage, Charge Overcurrent Detection Voltage and Delay Time.

(1) V_{CU} vs. T_a

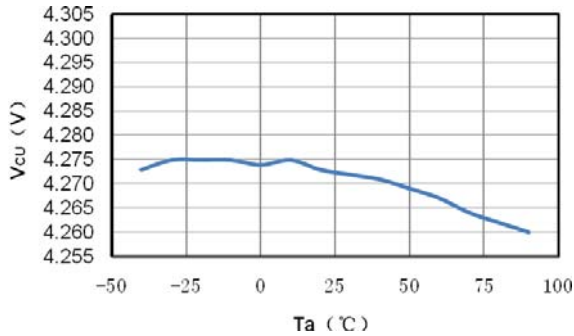

(2) V_{CR} vs. T_a

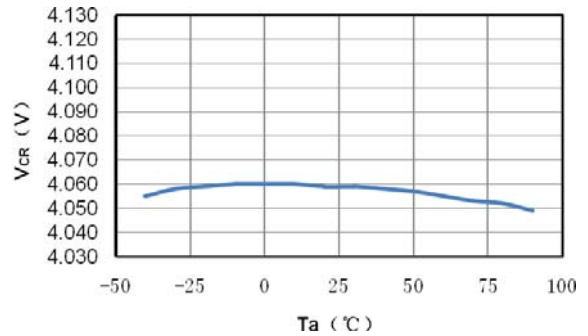

(3) V_{DL} vs. T_a

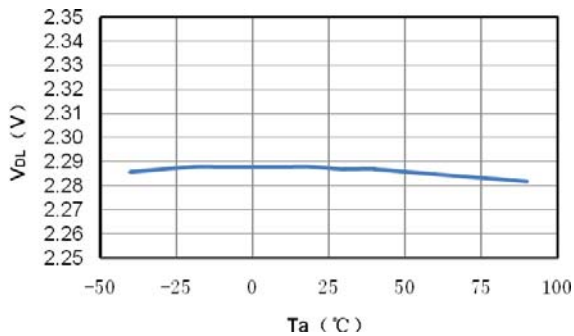

(4) V_{DR} vs. T_a

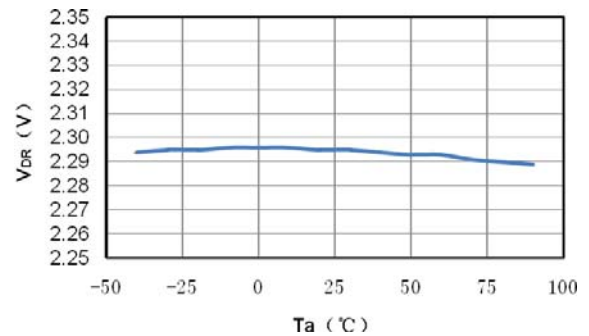

(5) T_{OC} vs. T_a

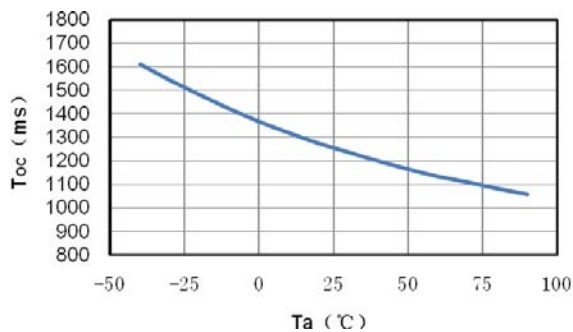

(6) T_{OD} vs. T_a

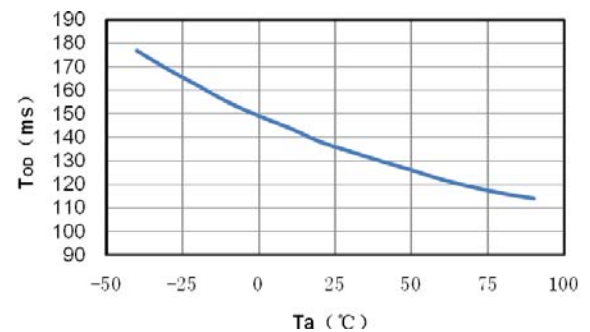

(7) V_{DIP} vs. T_a

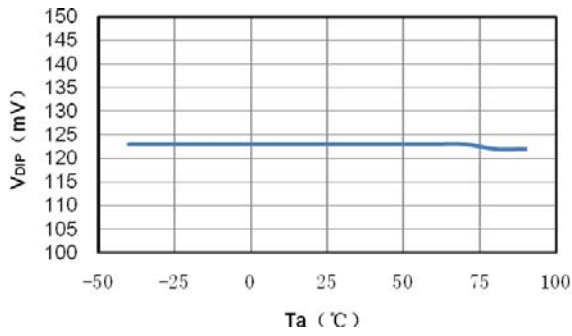

(8) T_{DIP} vs. T_a

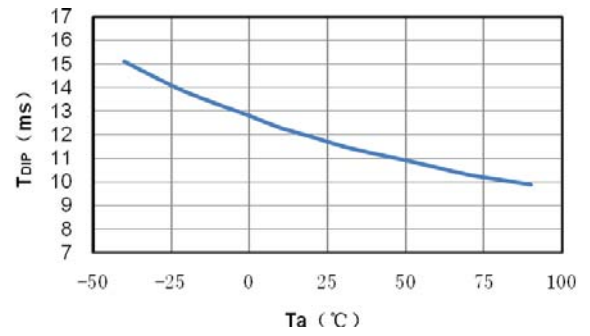

(9) V_{SIP} vs. T_a

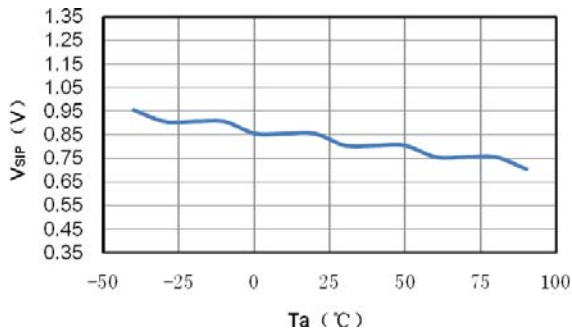

(10) T_{SIP} vs. T_a

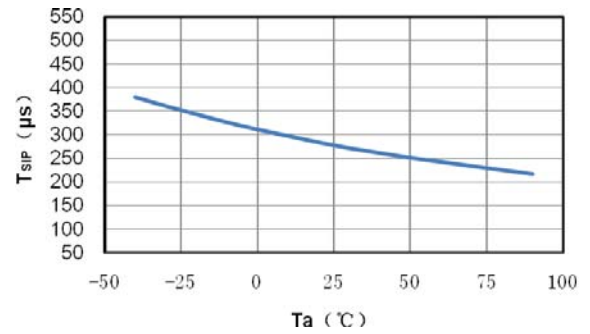

(11) V_{CIP} vs. T_a

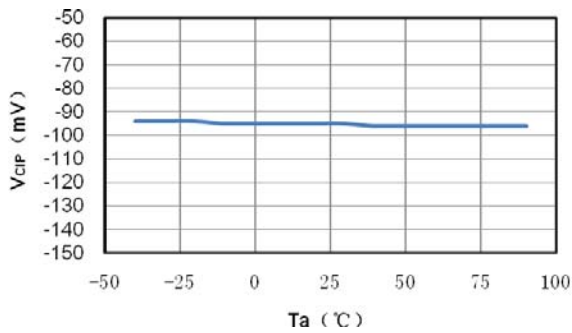

(12) T_{CIP} vs. T_a

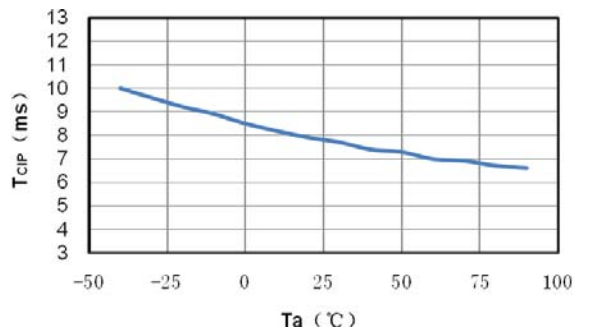

2. Current Consumption

(13) I_{DD} vs. T_a

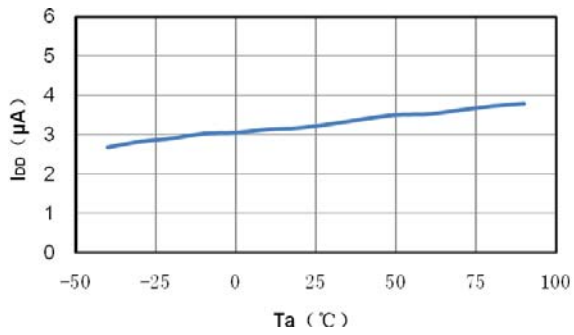

(14) I_{PD} vs. T_a

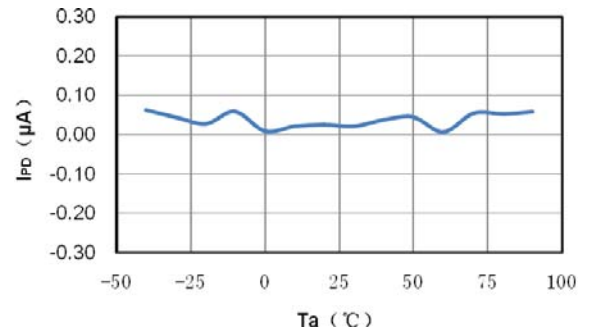

13. Package Information

13.1. DFN-6L Outline

Note:

1. All dimensions are in millimeters or inch.
2. The pad & body metal color are silver.

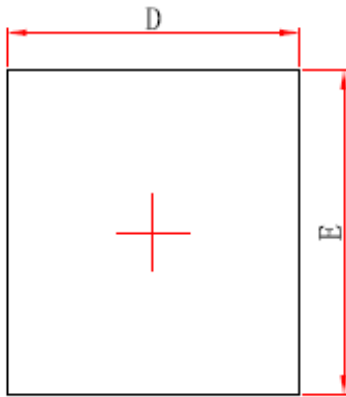

Top View

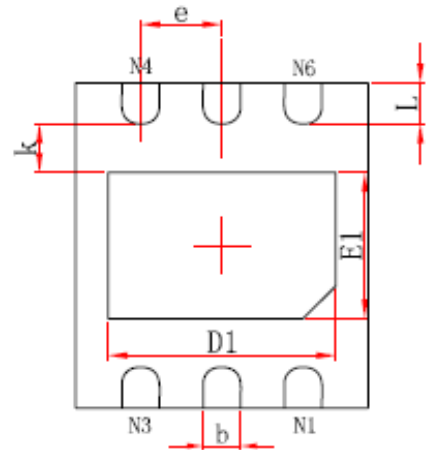

Bottom View

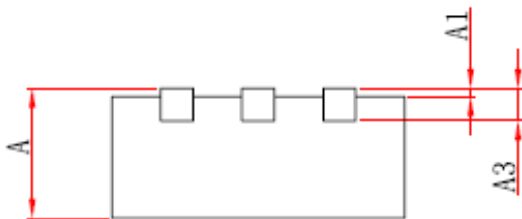

Side View

SYMBOL	Dimensions In Millimeters		Dimensions In Inches	
	MINIMUM	MAXIMUM	MINIMUM	MAXIMUM
A	0.450	0.550	0.018	0.022
A1	0.000	0.050	0.000	0.002
A3	0.150REF		0.006REF	
D	1.724	1.876	0.068	0.074
E	1.924	2.076	0.076	0.082
D1	1.300	1.500	0.051	0.059
E1	0.800	1.000	0.031	0.039
k	0.200MIN.		0.008MIN.	
b	0.180	0.280	0.007	0.011
e	0.500TYP.		0.020TYP.	
L	0.174	0.326	0.007	0.013

13.2. SOT-23-6 Outline

Note: All dimensions are in millimeters.

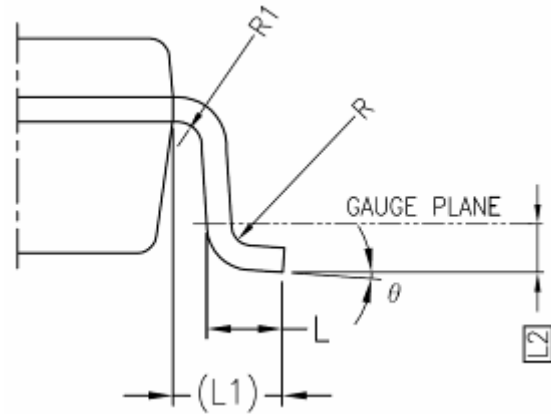
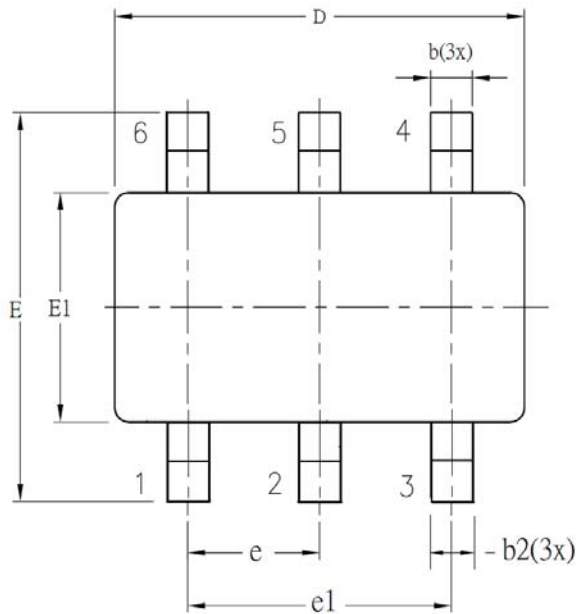

SYM BOL	ALL DIMENSIONS IN MILLIMETERS		
	MINIMUM	NOMINAL	MAXIMUM
A	-	1.30	1.40
A1	0	-	0.15
A2	0.90	1.20	1.30
b	0.30	-	0.50
b1	0.30	0.40	0.45
b2	0.30	0.40	0.50
c	0.08	-	0.22
c1	0.08	0.13	0.20
D	2.90 BSC		
E	2.80 BSC		
E1	1.60 BSC		
e	0.95 BSC		
e1	1.90 BSC		
L	0.30	0.45	0.60
L1	0.60 REF		
L2	0.25 BSC		
R	0.10	-	-
R1	0.10	-	0.25
θ	0°	4°	8°
$\theta 1$	5°	-	15°
$\theta 2$	5°	-	15°

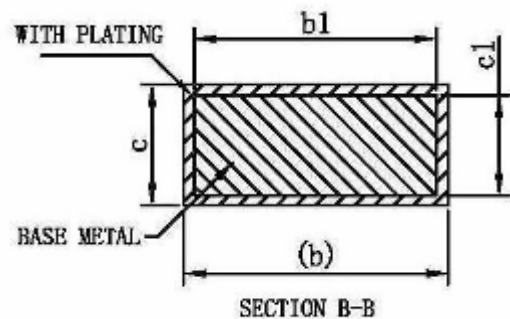
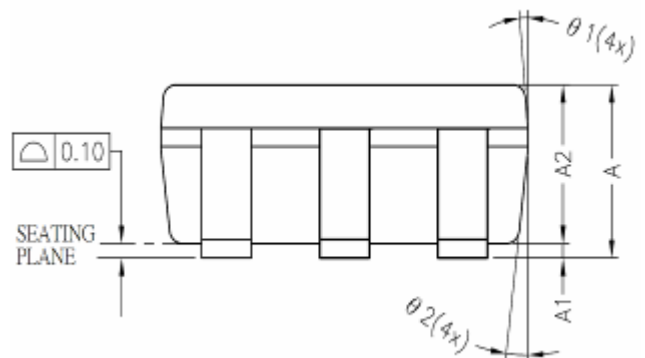

14. Revision Record

Major differences are stated thereafter:

Version	Page	Revision Summary
V01	-	First Edition
V02	All	Add in new model no., see page 6.
	17	Add in Characteristics (Typical value).
	20	Revise package size.
V03	7	Add in new model no.: HY2113-LA1A, HY2113-MA1A, HY2113LB1A and HY2113MB1A ◦
V04	9	Revise SOT-23-6 package marking rule.
V05	All	Add in new model no., see page 6 and page7.
V06	All	Add in new model no., see page 6 and page7.